

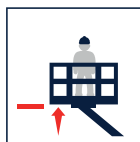

MXE200R



19,90 m



17,90 m

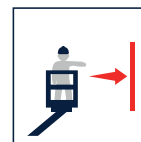

9,00 m (200 kg)



200 kg

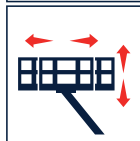

1400x700x1100 mm



65°+65°



400°



DS
Stabilizzatori a discesa in sagoma
Stabilisateurs dans le gabarit
Straight line stabilizers
Stützen innerhalb der Fahrzeugbreite



3,5 ton

MXE200R

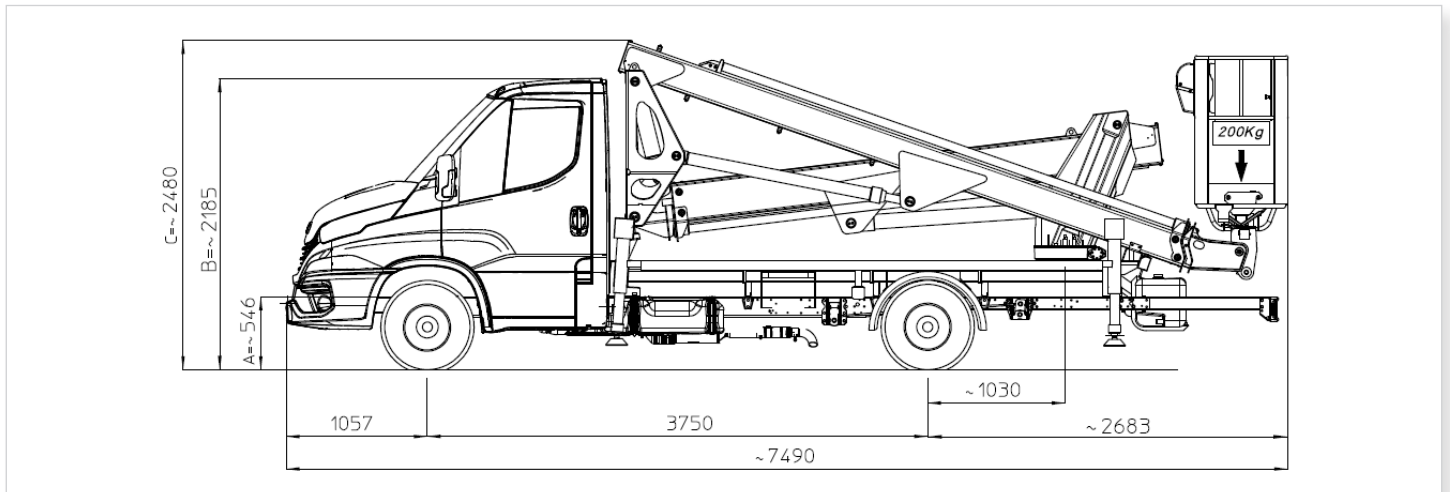
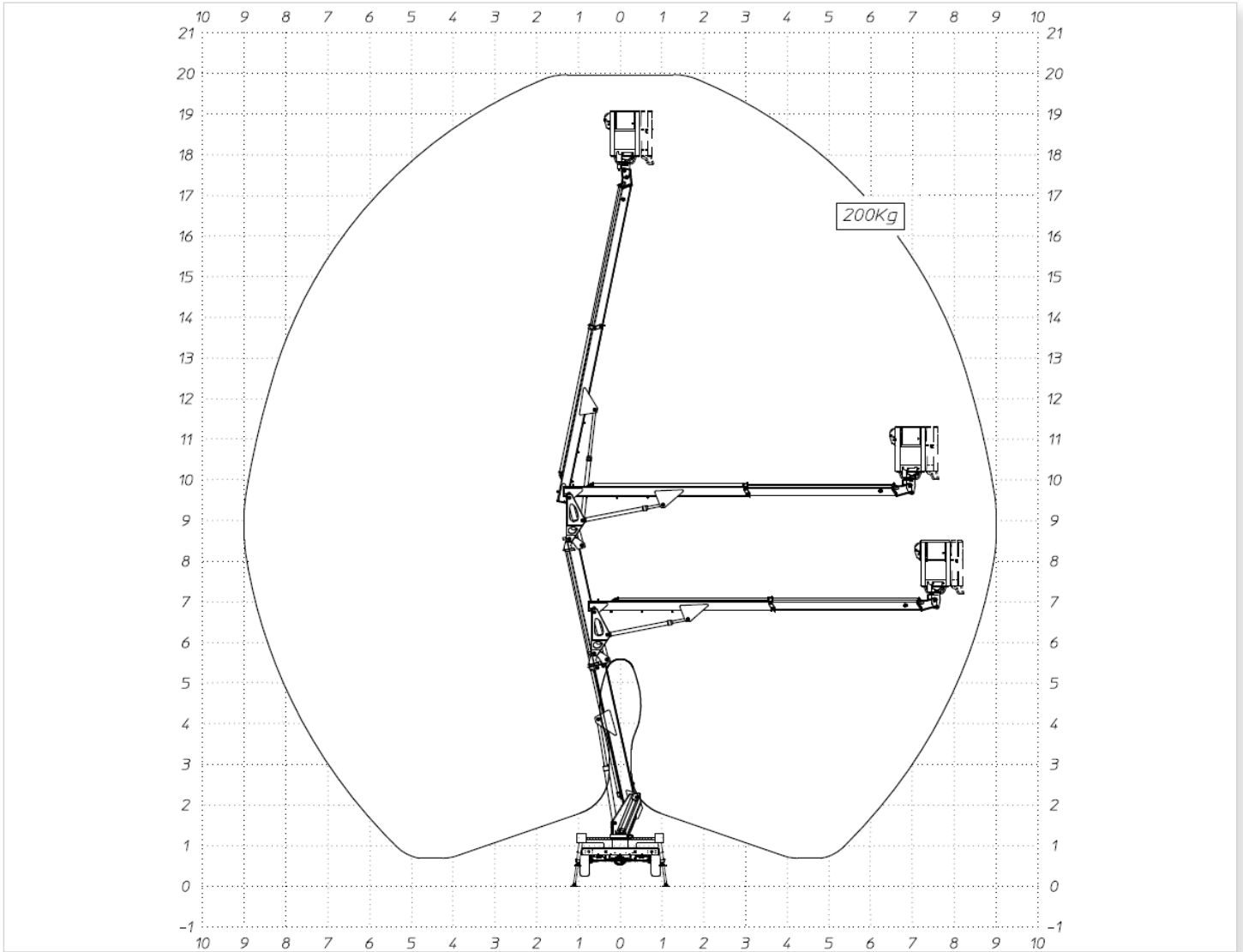

MULTITEL PAGLIERO S.P.A.
 Strada Statale, 114
 12030 MANTA (CN) - ITALY
 Tel. +39 0175 255211
 info@pagliero.com

Filiali
 Corso Piemonte, 54
 10099 S. MAURO T. SE (TO) - ITALY
 Tel. +39 011 2236792

Via dell'Offelera, 106
 20861 BRUGHERIO (MB) - ITALY
 Tel. +39 039 883393/4

MULTITEL INTERNATIONAL SASU
 87, rue du Morellon
 38070 ST. QUENTIN FALLAVIER - FRANCE
 Tel. +33 (0) 4 74 94 63 19
 accueil@multitelinternational.com

MULTITEL EXPORT SALES GmbH
 Carl-Zeiss-Straße, 34
 52477 ALSDORF - DEUTSCHLAND
 Tel. +49 (0) 2404 675 580
 exportsales@pagliero.com

MULTITEL UK LTD - operational headquarter
 Unit 11 Bilton Court Bilton Way
 LU11LX LUTON - UK
 Tel. +44 (0) 1582 952778
 info.uk@pagliero.com

MULTITEL IBERICA SL
 C/ Luxemburg, 12
 08520 LES FRANQUESES DEL VALLÈS, BARCELONA - ESPAÑA
 Tel. +34 93 22 05 633
 info.iberica@pagliero.com

www.multitelgroup.com

MULTITEL MXE200 R

Iveco Daily 35S14H 4x2 Euro6E



Codice

1D94562

Ente	Rev.	Descrizione	Data	Dis.	Contr.	Ap.AQ
MRK	0	EMISSIONE	20/01/25	L.C.	R.F.	F.F.

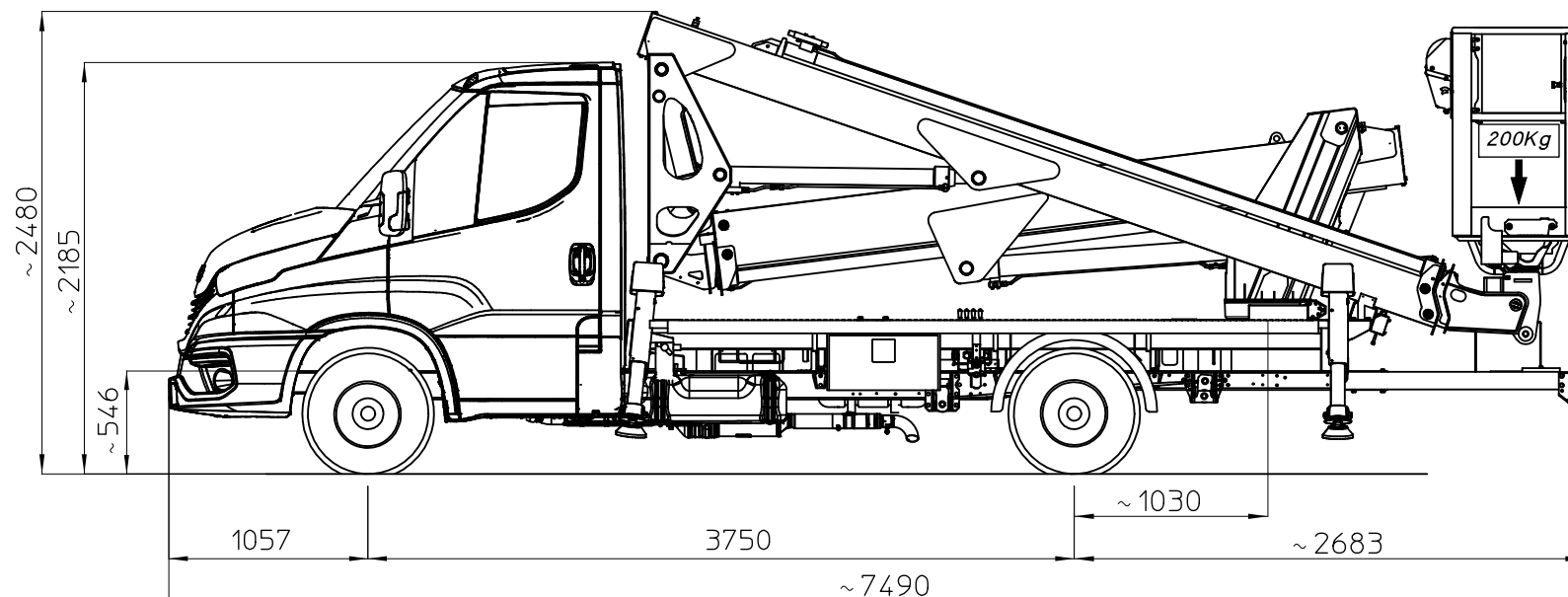
INGOMBRO - SCHEDA 54/1 - Rev. 0 - 15/12/00

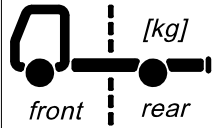

VEHICLE DATA		
axle weight		[kg]
	front	rear
unladen	1240	440
max permissible	1900	2240
		 3,50

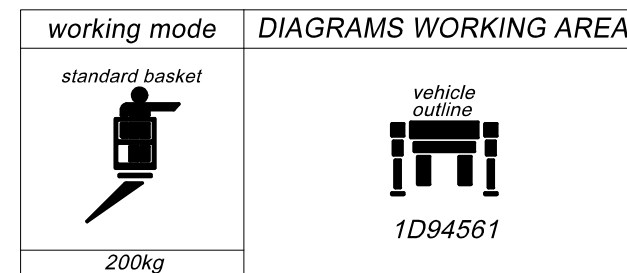
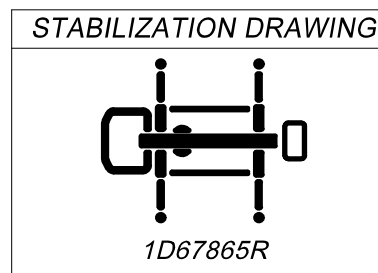

I - Le quote riportate in disegno sono indicative, possono subire variazioni in base alle dimensioni dell'autocarro.

F - Les cotes indiquée dans le dessin sont indicatives et peuvent subir des variations selon aux dimensions du porteur.

E - The dimensions shown in the drawing are an indication and may undergo changes related to the truck sizes.

D - Die in der Zeichnung angegebene Maße sind Richtwerte und können je nach Fahrzeuggröße variieren.

MULTITEL MXE200 R

Iveco Daily PTT=3500Kg

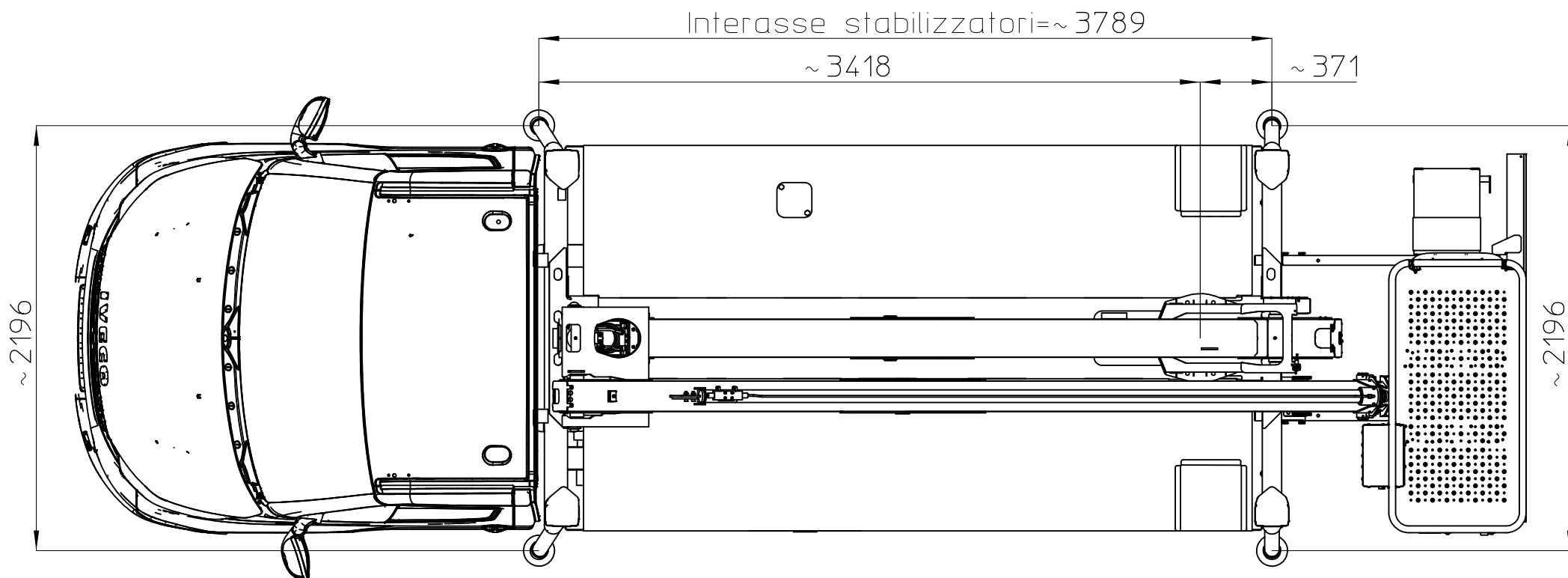



Codice			1D67865R			
Ente	Rev.	Descrizione	Data	Dis.	Contr.	Ap.AQ
MRK	0	EMISSIONE	08/05/25	L.C.	R.F.	F.F.
DIAGRAMMA - SCHEDA 54/2 - Rev. 0 - 15/12/00						

MULTITEL

MXE200R

Codice			1D94561			
Ente	Rev.	Descrizione	Data	Dis.	Contr.	Ap.AQ
MRK	1	EMISSIONE	07/05/25	L.C.	R.F.	F.F.
DIAGRAMMA - SCHEDA 54/2 - Rev. 0 - 15/12/00						

vehicle outline

TON
3,50



200kg

9.00m ±5%

