

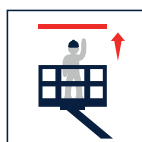

SMX170



16,85 m



14,85 m

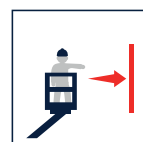

200 kg – 7,8 m



200 kg

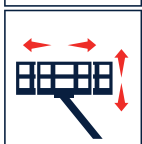

1400x700x1100 mm

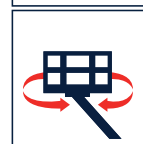

90°+90°



360°

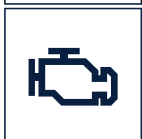

KUBOTA
10,9kW/ 3200 rpm



2,2 kW/ 230 V
50 hz / 1500 rpm



1,1 km/h
2,2 km/h

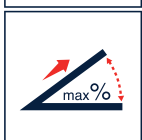

14°/25%



2200 kg

SMX170

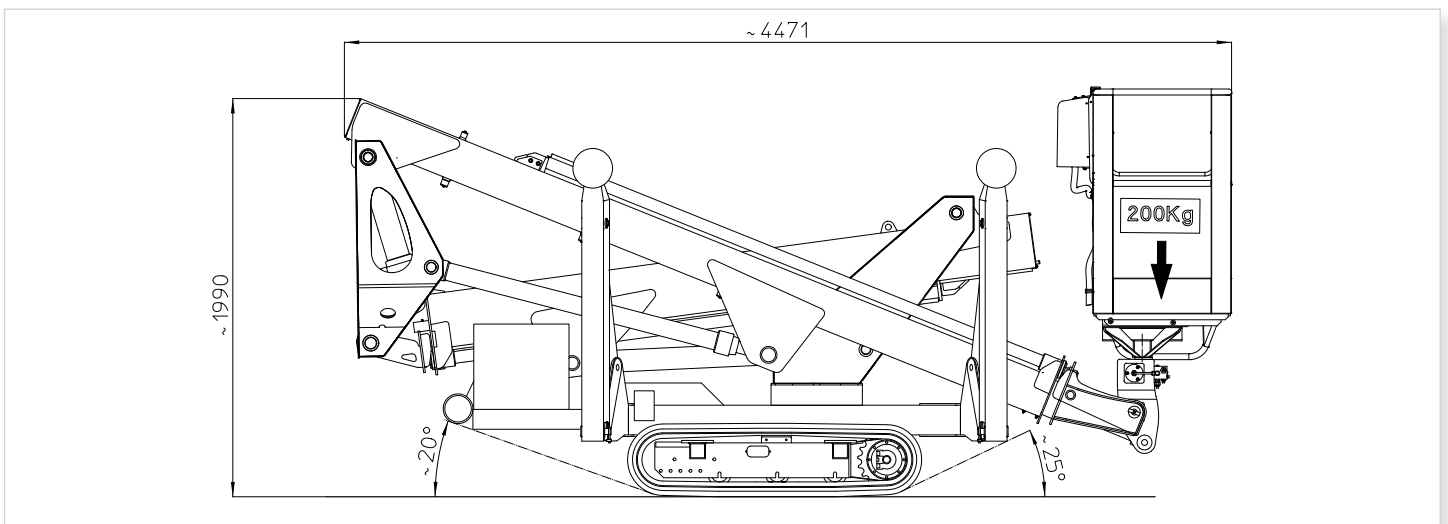
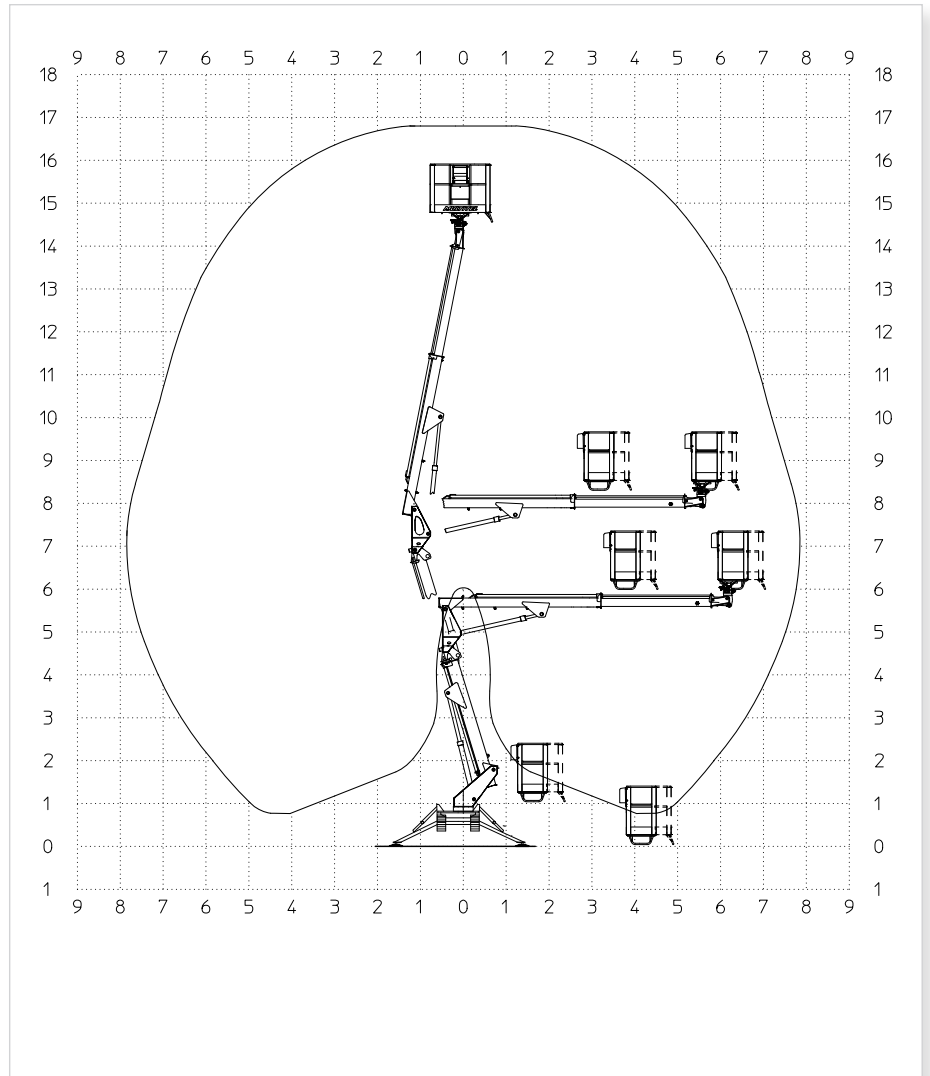
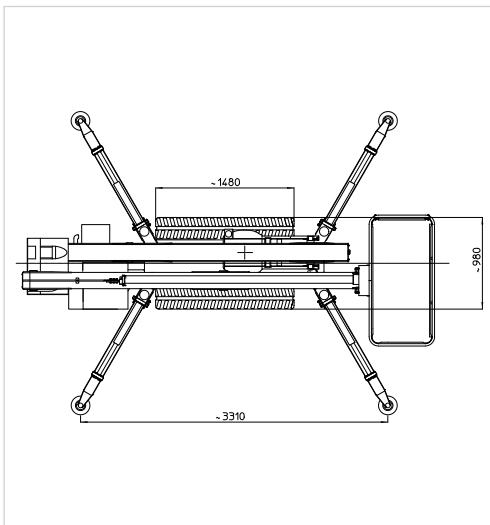
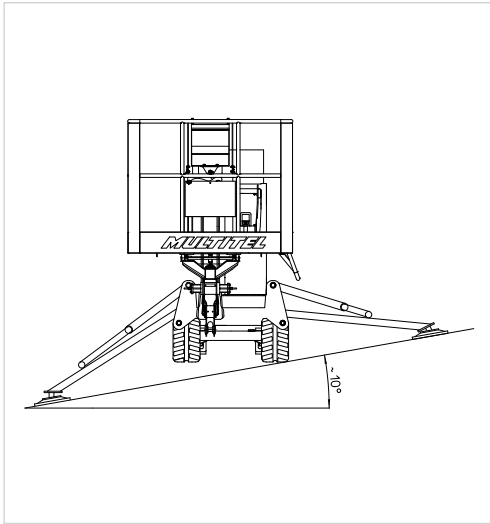

MULTITEL PAGLIERO S.P.A.

Strada Statale, 114
12030 MANTA (CN) - ITALY
Tel. +39 0175 255211
info@pagliero.com

Filiali

Corso Piemonte, 54
10099 S. MAURO T. SE (TO) - ITALY
Tel. +39 011 2236792

Via dell'Offelera, 106
20861 BRUGHERIO (MB) - ITALY
Tel. +39 039 883393/4

MULTITEL INTERNATIONAL SASU

87, rue du Morellon
38070 ST. QUENTIN FALLAVIER - FRANCE
Tel. +33 (0) 4 74 94 63 19
accueil@multitelinternational.com

MULTITEL EXPORT SALES GmbH

Carl-Zeiss-Straße, 34
52477 ALSDORF - DEUTSCHLAND
Tel. +49 (0) 2404 675 580
exportsales@pagliero.com

MULTITEL UK LTD - operational headquarter

Unit 11 Bilton Court Bilton Way
LUTON LU1 1LX - UK
Tel. +44 (0) 1582 952778
info.uk@pagliero.com

MULTITEL IBERICA SL

C/ Luxemburg, 12
08520 LES FRANQUESES DEL VALLÈS, BARCELONA - ESPAÑA
Tel. +34 93 22 05 633
info.iberica@pagliero.com

www.multitelgroup.com