

ADDENDUM 002

May 14, 2026

TO ALL CONTRACTORS:

This Addendum is hereby made a part of the Contract Documents dated April 10, 2026.

Lake Charles Event Center Green Rooms – CP 3507
900 Lakeshore Drive
Lake Charles, Louisiana 70601
GHC Project No. 4024119

The following items shall be considered part of the contract documents and shall be included in the same when Construction Contract is executed. Changes made by Addenda shall take precedence over Original Documents. Any changes, which may affect construction or proper installation of materials, equipment or fixtures, not specifically mentioned in this addendum, shall be brought to the attention of Designer before submitting bid. Otherwise, such conditions, if found later to exist, must be worked out in an acceptable manner without additional cost to the Owner. Prime Contractors are hereby advised to call attention of all subcontractors to changes, which may affect their work.

GENERAL

GENERAL

1. Attached is the **Mandatory Pre-Bid Conference Agenda / Meeting Minutes** and **Sign-In Sheet**.

CLARIFICATIONS

1. An additional dimension plan has been added to the following sheets: **A112, A113, A114, and A115**.
2. Revisions have been made to sheet: **G002** to update the toilet accessory labels in Details **S2, S3, S4, and T1** for clarity.
3. All fur downs, ceiling systems and lighting fixtures as detailed above lockers in Alternate #2 to be included in Alternate #1 scope. Reference Detail 5/A117
4. Revisions have been made to sheet: **ID131** details to include additional features/requirements for interior signage.

RFIs:

1. Question: In reference to Drawings A112, A113, A114, and A115, Partition types A & G are detailed to extend to bottom of structure. In some areas this height is 10' to 20' above ceiling height. Existing Ducts, Piping, Stairs Stepped and at an angle restrict access to be able to install partitions to bottom of structure. Please advise by addendum if partition types A&G can terminate just passed ceiling heights.
Answer: See revised sheets **A112, A113, A114 & A115** for wall type changes. All other references to Wall types "A" & "G" will remain unchanged.

ARCHITECTURAL

SPECIFICATIONS:

1. **Section 00 0005** – Delete all references to 00 0009 Supplementary Conditions in the Specifications. The Owner's front end documents 00500 Agreement and 00510 A201 General Conditions along with additional Owner front end requirements.
2. **Section 00 0010a** - Owner's Front End Documents includes a Notice to Proceed and Notice of Award as section 00640, Owners documents will be utilized contractually, therefore Architect's documents 00 0010a Notice of Award and 00 0010b Notice to Proceed will not be used and can be disregarded.

DRAWINGS

1. **Sheet A112, A113, A114 and A115:** Include dimension plan and update partition types as referenced in **RFI Question #1**
2. **Sheet G002:** Updated toilet accessory labels in Details S2, S3, S4, and T1
3. **Sheet ID131:** details to include additional features/requirements for interior signage.

PRIOR APPROVALS / SUBSTITUTIONS

1. **Prior Approval - Lighting Fixtures:** See attached Engineers comments for approved / rejected.
2. **Prior Approval - Metal Studs:** The proposed manufacturer US Frame Factory does not meet the minimum requirements of Specification **Section 05 4000 Cold-Formed Metal Framing** and is therefore not approved. Substitution has been **rejected**.
3. **Prior Approval – Acoustical Ceiling Grid and Tile:** The proposed manufacturer CertainTeed meets the minimum requirements of Specifications **Section 09 5100 Acoustical Ceilings** for the following items -- Ceiling Grid Suspension Systems for Acoustical Ceiling Systems: 15/16" EZ Stab Classic System; Ceiling Tiles for acoustical ceiling systems: **AC-1:** Symphony m 1222-75-1; Ceiling Tiles for acoustical ceiling systems: **AC-2:** Vinylrock 1142-CRF1. Substitution has been **approved**.
4. **Prior Approval – Gypsum direct-hung grid suspension system:** The proposed manufacturer CertainTeed meets the minimum requirements of Specifications **Section 09 2116 Suspension System** for the following items – Main beams and cross furring members that interlock to form modular supporting network. Substitution has been **approved**.
5. **Prior Approval – Suspended Wood Ceilings:** The proposed manufacturer CertainTeed Architectural; Continuous Linear does not meet the minimum requirements of Specification **Section 09 5426 Suspended Wood Ceilings** and is therefore not approved. Substitution has been **rejected**.

END OF ADDENDUM NUMBER TWO

MANDATORY PRE-BID CONFERENCE ATTENDANCE RECORD



PROJECT: Lake Charles Event Center Green Rooms Project
 OWNER PROJECT NO.: CP 3507
 GDS PROJECT NO.: 4024119

LOCATION: 4331 E. Broad Street Lake Charles LA
 DATE: 8-May-26
 TIME: 11:00 AM

NAME	COMPANY	SIGNATURE	PHONE NUMBER	E-MAIL ADDRESS
Jason Funderburgh	Grace Design Studios		337.513.0760	jfunderburgh@grace-design.com
James Trache	Grace Design Studios		337.513.0760	jtrache@grace-design.com
Garrett Abel	Pat Williams Construction	<i>Garrett Abel</i>	337-433-4300	estimating@patwilliamsconstruction.com
Tabetha Nunez	Alfred Palma	<i>A. Palma</i>	337-436-0830	Estimating @ a.palma inc. com
Eddie Touchstone	ALFRED PALMA	<i>E. Touchstone</i>	337-436-0830	estimating@apalmainc.com
Asen Bounds	SETEX Construction	<i>Asen Bounds</i>	409-842-8181	Bids@setexconstruction.com
Jeremy Chapman	Old River Construction	<i>Jeremy Chapman</i>	337-329-3655	OLDRIVER JEREMY @ Yahoo.com
MIKE KRANS	ILKRAUS CONST.	<i>Mike Krans</i>	357-377-5588	MIKEKRANS95@bnet.com
Chris Talbert	Sam Istre Const.	<i>Chris Talbert</i>	337-477-1038	Chris & Sam Istre construction.com
JIMMY TRACHE				
Jeremy Wood	Shannon Smith Const	<i>Jeremy Wood</i>	337-474-5157	jeremywood@ssconstruct.net
Seth Priole	Seth Priole Const	<i>Seth Priole</i>	337-842-4451	S.priole & priole.com
Matthew Links	COLC	<i>Matthew Links</i>	337-485-3355	matthewlinks@cityoflc.us
<i>NO FURTHER FRIMS</i>				

May 8, 2026 @ 11:00 AM

RE: Lake Charles Event Center Greenrooms
900 Lakeshore Drive
Lake Charles, LA
Grace Project #4024119
CP No.: **3507**

PRE-BID CONFERENCE AGENDA

SIGN IN & INTRODUCTIONS

- The following individuals were designated as the contact person for their organizations:
- Owner: City Of Lake Charles
- Owner's Representative: Michael Castille
- Design Team: Designer – Grace Design Studios: Jason Funderburgh
Designer – Grace Design Studios: James Trache

GENERAL BIDDING INFORMATION

- Attendance at the Pre-Bid Conference is **Mandatory** for all General Contractors interested in bidding the project.
- Please note the Bid Date as specified. Sealed bids will be received until **2:45 PM**. Local Time, **Tuesday, May 19, 2026** to the Clerk of Council of the City of Lake Charles, 4th floor of City Hall at 326 Pujo Street, Lake Charles Louisiana, 70601, and will be read aloud in the City Council Chambers on the 1st Floor of City Hall at 326 Pujo Street, Lake Charles Louisiana, 70601. No bids will be received after 2:45 PM on the same day and date.
- Bids may be submitted electronically by using www.bidexpress.com or by mail or hand delivered
- Bidders shall be solely responsible for ensuring that their bids are received on or before the bid opening. Neither the Owner nor Design Team shall be responsible for any failure of the delivery method chosen.
- No bid shall be considered or accepted unless the bid is accompanied by bid security in an amount not less than five percent (5%) of the Base Bid and all Additive Alternates.
- The project is tax exempt. General Contractors, Sub-Contractors, Subs of Sub-Contractors, etc. are tax exempt, **ALL** must fill out a tax exemption form. These shall be submitted through the Contractor to the Owner for signature. General Contractor are encouraged to inform all sub-contractors of the tax exemption when soliciting pricing. Tax exemption is for materials purchased for this project only.
- The successful bidder shall be required to furnish a performance bond in an amount equal to one hundred percent (100%) of the Contract amount, which shall be written by a surety or insurance company currently on the U.S. Department of the Treasury Financial Management list of approved bonding companies which is published annually in the Federal Register, or by a Louisiana domiciled insurance company with at least an A-

rating in the latest printing of the A.M. Best's Rating Guide to write individual bonds up to ten percent (10%) of policyholders' surplus as shown in the A.M. Best's Rating Guide or by an insurance company in good standing licensed to write bonds which is either domiciled in Louisiana or owned by Louisiana residents, all in accordance with **LAS-R.S. 38:2219**.

- Post Bid Documents shall be submitted within **ten (10) calendar days** after the date of opening the bids by **May 28, 2026 @ 4:00 PM**. These include items listed in the "Instruction to Bidders" Articles VI, and VII.

ADDENDA AND INTERPRETATIONS

- Per the Instructions to Bidders: Any bidder requiring clarification or interpretation of the Bid Documents or submitting a Substitution Request, shall submit a **written request** to the Prime Designer, **no later than (7) days prior** to the bid date and time.
- All requests **must be submitted electronically** to the email addresses listed in the Architect's Instructions to Bidders.
- All interpretations, clarifications and supplemental instructions will be issued **only by written Addenda** to the Specifications and/or Drawings.
- Addenda will be issued electronically through **BidExpress** no later than **72 hours prior to the bid**, in accordance with the Instructions to Bidders.

CONSTRUCTION CONTRACT OVERVIEW

- **Contract Time: 270** consecutive calendar days after the Notice to Proceed.
- **Final Acceptance and Completion of General Conditions: 315** consecutive calendar days after the Notice to Proceed.
- **Liquidated Damages: \$TBD based on Contract Value, see Instructions to Bidders Item 8.1 per calendar day** for failure to achieve Substantial Completion within the contract time.

REVIEW OF SCOPE OF WORK

A. GENERAL PROJECT DESCRIPTION

Greenroom additions and renovations project to the Lake Charles Event Center, with the Base Bid consisting of an approximately **1438 sf.** addition for a new multi-purpose "Green Room". This bid also includes **three (3) alternates** which are as follows:

Alternate No. 1: Includes the interior renovation and remodeling to the East and West restrooms and showers.

Alternate No.2: Includes lockers with a curtain system added to **Alternate No. 1** Scope.

Alternate No. 3: Includes the South restroom, showers, dressing rooms and lounges (East and West sides of the arena) Green Rooms.

This project is Parish funded, requiring additional processes for capture and funding of unforeseen conditions.

Scope of work: THIS IS A TURN-KEY PROJECT which includes, but is not limited to:

- Interior demolition and removal
- Paving and Drainage
- Interior framing walls
- Mechanical, Electrical, Plumbing (MEP) upgrades
- Interior finish replacements
- Temporary restrooms and security protection
- Exterior structural concrete repair and CMU in-fill
- HVAC scope
- Fire Sprinkler upgrades which includes head relocation

SELECTIVE DEMOLITION SCOPE (INCLUDES BUT IS NOT LIMITED TO):

- Removal of plumbing fixtures, mechanical and electrical systems
- Removal of Fire Protection lines and hose hook-ups
- Removal of interior finishes
- Removal of existing HVAC systems
- Removal of existing ACT and grid systems
- Removal of existing drywall ceiling and finishes
- Removal of metal wall panels
- Removal of flooring finishes, ie: carpet, tile, wood
- Removal of doors, frames and hardware
- Removal of interior wall framing
- Removal of exterior concrete parking /driveway areas
- Removal or exterior hardscape areas

NEW CONSTRUCTION SCOPE (INCLUDES BUT IS NOT LIMITED TO):

- Installation of new concrete paving
- Installation of new masonry wall infill
- Installation of new tapered insulation and roofing system
- Installation of new gutter
- Installation of balcony drains and piping
- Installation of cement-based stucco system
- Installation of new storefront systems
- Installation of new plumbing, mechanical and electrical systems
- Installation of new plumbing fixtures, mechanical devices and electrical devices
- Installation of new interior metal stud walls
- Installation of new wall finishes
- Installation of new floor and ceiling finishes
- Installation of new doors, frames and hardware
- Installation of millwork, pass-thru glass panels
- Painting of walls, ceilings, doors, and trim

B. FURNITURE AND EQUIPMENT HANDLING

- The Contractor will be responsible for moving equipment and furniture in rooms/spaces affected by the scope of work.
- Flooring protection shall be provided during moving and storage activities.
- The Contractor shall document any existing damage to the equipment and furniture prior to moving and provide photographs to the Design Team and Owner.
- All items shall be tagged with the room from which it was moved and reinstalled in that room upon completion of the scope.
- The Contractor will be responsible for any damage to equipment and furniture which occurs.
- Contractor to visit site and verify extents of existing furniture, prior to bid.

C. SCHEDULING AND BUILDING ENVELOPE REQUIREMENTS & EXPECTATIONS

- The Contractor shall provide overall project schedule, and **weekly progress schedule** specifically for areas related to **HVAC / Mechanical** scope.
- Work affecting the building envelope must maintain **environmental and security integrity**.
- The Contractor to provide protection of interior spaces and finishes prior to beginning work.
- Owner specific scheduling for event to be coordinated into contractors.

D. ACTIVE BUILDING REQUIREMENTS

- This is an **active occupied commercial building**, and all Contractor personnel **must always be identifiable**.
- The **First-Floor** areas as indicated will remain accessible during construction to the public during business hours. Workers shall remain in areas pertaining to the scope of work.

Architect recommends contractor to visit the site and key component areas where access is needed

QUESTIONS & DISCUSSION:



1450 Seaboard Drive
Baton Rouge, LA 70810
P: 225.332.0222

parisheng.com | contact@parisheng.com

May 12, 2026

Lake Charles Event Center Green Rooms
Lake Charles, Louisiana
GHC Architects, LLC Proj. No. 4024119

ADDENDUM #2

The following items shall be considered part of the Contract Documents for the above referenced project and shall take precedence over any conflicting statements contained therein. Revise all other notes, schedules, details, elevations, and sections as required.

ELECTRICAL ITEMS:

Clarifications:

1. The submitted proposed alternate for fixture type "G" (AFX Lighting #LANP36LAJUDLB) is rejected as it does not have the same finish options and stem length as the specified type "F" fixture.
2. The submitted proposed alternates for fixture types "H1" and "H2" (Kuzco Lighting #CRADLE-494216-FINISH and #CRADLE-494224-FINISH) are rejected as they do not match the aesthetic of the specified types "H1" and "H2".
3. The submitted proposed alternate for fixture type "J" (Finelite #HP-2-R-D-LENGTH-TL700-840-F-96LG-120-SC-FC-10%-CEILING-FE-FINISH) is rejected as it shown as a 4" wide fixture instead of the 2.6" specified.
4. The submitted proposed alternate fixture for type "Z" (Chloride #PLACEMBZ) is rejected as it does not match the aesthetic of the specified type "Z" fixture.

PRIOR APPROVAL:

NOTE: Acceptance of a particular manufacturer does not excuse that manufacturer from meeting the plans and specification. Compliance with specifications is the responsibility of the prior approval manufacturer.

Product

Light Fixture Type "B1"
Light Fixture Type "B2"
Light Fixture Type "B3"
Light Fixture Type "B4"
Light Fixture Type "F"
Light Fixture Type "K"
Light Fixture Type "L"
Light Fixture Type "M"

Model

Lightolier
Lightolier
Lightolier
Lightolier
Alora Mood
Day-Brite
Day-Brite
Kelvix

Addendum – Lake Charles Event Center Green Rooms

May 12, 2026

Page 2

Light Fixture Type “X”	Chloride
Lighting Control Power Pack	Wattstopper
Wall Occupancy Sensor Switch	Wattstopper
Ceiling Occupancy Sensor	Wattstopper
Dimming Power Pack	Wattstopper
Dimming Room Controller	Wattstopper
Standard Switches	Wattstopper
Dimmer Switches (Forward/Reverse)	Wattstopper
Dimmer Switches (0-10V)	Wattstopper

If you have any questions, please contact our office.

Parish Engineering, LLC

ROOM SCHEDULE				
ARCH ROOM NAME	ROOM NUMBER	SIGN TYPE	SIGN NAME	NOTES
GALLERY	216	I	MULTIPURPOSE ROOM	
MULTIPURPOSE ROOM	100	I	MULTIPURPOSE ROOM	
RESTROOM VESTIBULE	101	II	RESTROOM	
MECHANICAL	103	I	MECHANICAL	
CATERING	104	I	CATERING	
LOCKER ROOM A	192	I	LOCKER ROOM A	
DRESSING ROOM 1	190	I	DRESSING ROOM 1	X2 LOCATIONS
DRESSING ROOM 2	189	I	DRESSING ROOM 2	
DRESSING ROOM 3	188	I	DRESSING ROOM 3	
RESTROOMS/SHOWERS	207	V	RESTROOM	
LOCKER ROOM B	184	I	LOCKER ROOM B	
DRESSING ROOM 4	208	I	DRESSING ROOM 4	X2 LOCATIONS
DRESSING ROOM 5	209	I	DRESSING ROOM 5	
DRESSING ROOM 6	210	I	DRESSING ROOM 6	
RESTROOMS/SHOWERS	211	V	RESTROOM	
WEST LOUNGE	203	I	WEST LOUNGE	X2 LOCATIONS
VEST	106	I	TBD	
RESTROOM	105	II	RESTROOM	
LOCKER C	107	I	LOCKER ROOM	
RESTROOMS/SHOWERS	108	V	RESTROOM	X2 LOCATIONS
EAST LOUNGE	109	I	EAST LOUNGE	X2 LOCATIONS
VEST	115	I	TBD	
RESTROOM	110	II	RESTROOM	
LOCKER D	114	I	LOCKER D	
RESTROOMS/SHOWERS	113	V	RESTROOM	
ROOM	#	I	SIGN NAME	

THIS SET OF DOCUMENTS INCLUSIVE OF DRAWINGS, SPECIFICATIONS, AND APPENDIX MAY NOT BE COPIED, REPRODUCED, OR ELECTRONICALLY TRANSMITTED IN ANY FORM OR BY ANY MEANS WITHOUT THE EXPRESS WRITTEN CONSENT OF GRACE HERBERT CURTIS ARCHITECTS, LLC. NO PART OF THIS DOCUMENT IS TO BE REPRODUCED OR TRANSMITTED IN ANY FORM OR BY ANY MEANS WITHOUT THE EXPRESS WRITTEN CONSENT OF THE ARCHITECT, GRACE HERBERT CURTIS ARCHITECTS, LLC.

SEE SHEETS G001/G002 FOR GENERAL NOTES APPLICABLE TO THE ENTIRE DRAWING SET

NOTE: SIGNS ADJACENT TO EXISTING AREA WITH EXISTING SIGNAGE SUBJECT TO MATCH EXISTING. CLIENT TO MAKE FINAL DETERMINATION FOR SIGNAGE DIRECTION.

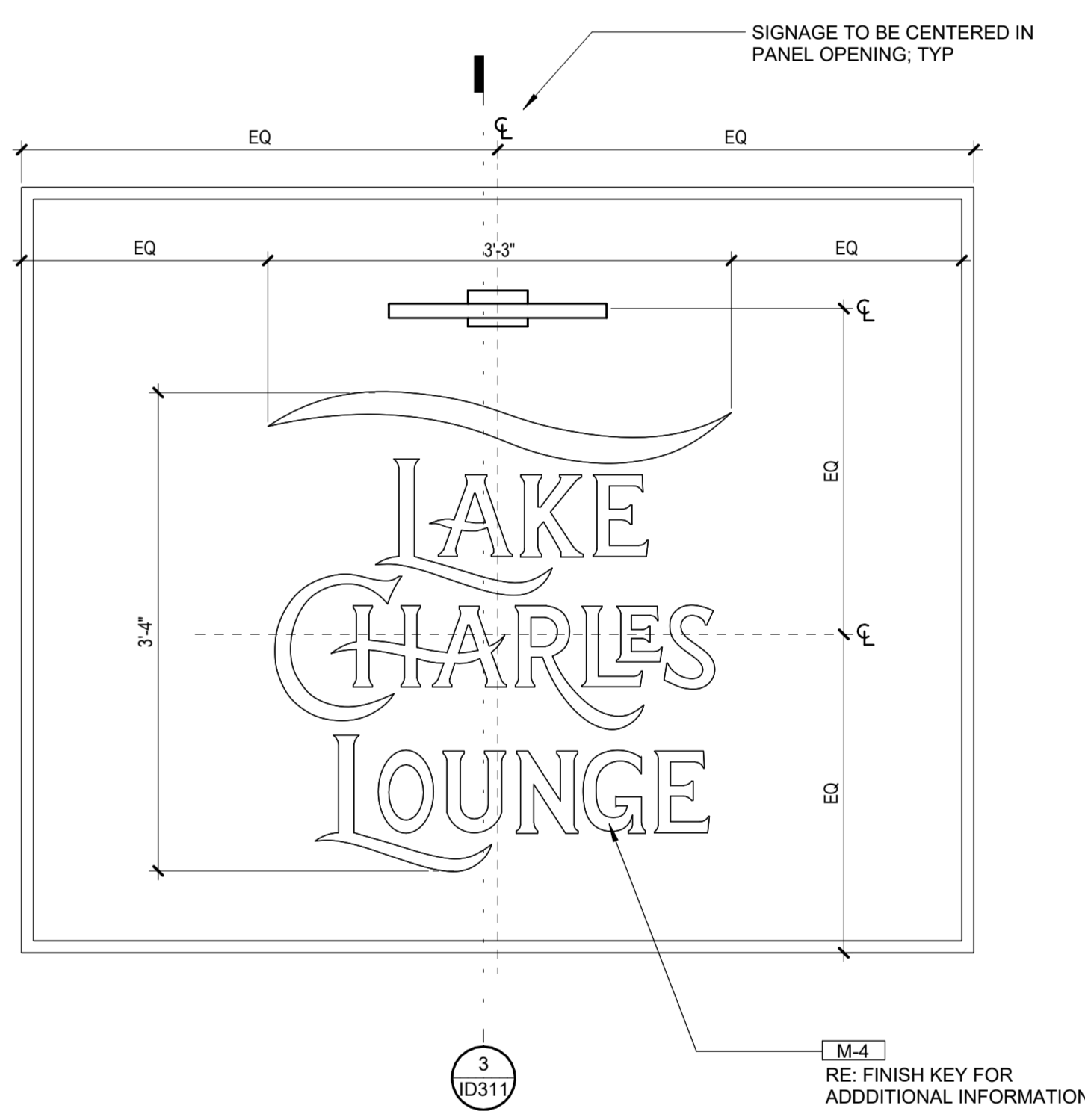

1 SIGNAGE PLAN - OVERALL REFER TO ID101 FOR INFORMATION REGARDING PROJECT ALTERNATES 1-3
1/8" = 1'-0"

2 MULTIPURPOSE ROOM - S - SIGNAGE
1" = 1'-0"

SIGNAGE BASIS OF DESIGN: ASI 3D FORM SERIES

SIGN TYPE I
ADA COMPLIANT AUXILIARY ROOM DOOR ENTRANCE SIGNS;
RE: SPECIFICATIONS FOR INSTALLATION

SIGN TYPE II
ADA COMPLIANT RESTROOM ENTRANCE SIGNS;
RE: SPECIFICATIONS FOR INSTALLATION

SIGN TYPE III
ADA COMPLIANT EXIT SIGNS;
RE: SPECIFICATIONS FOR INSTALLATION

SIGN TYPE IV
ADA COMPLIANT EVACUATION MAP SIGNS;
RE: SPECIFICATIONS FOR INSTALLATION

SIGN TYPE V
ADA COMPLIANT RESTROOM ENTRANCE SIGNS;
RE: SPECIFICATIONS FOR INSTALLATION

KEY PLAN
TRUE NORTH

Lake Charles Event Center Green Rooms -
Capitol Project No. 3507
 CITY OF LAKE CHARLES
 LAKE CHARLES, LOUISIANA

NO.	DESCRIPTION	DATE
1	Addendum 002	05/12/26

DATE: 04/10/26
 PHASE: BIDDING DOCUMENTS
 ISSUED FOR: ISSUED FOR BID
 PROJECT NO: 4024119

SIGNAGE PLAN - OVERALL

SHEET NUMBER
ID131