

Aussie Pumps

Reliable Products ... Reliable People



AUSSIE QUIK PRIME PETROL DRIVE FIRE FIGHTING PUMPS ... SIZE DOES MATTER

AUSSIE FIRE CHIEF HERE'S WHY IT'S BETTER

POWERED by
HONDA



Metal caps
& chains

Polished marine
grade aluminium
body

Separate
replaceable
suction flange

BIG 2"
suction port

Big belly body
means FAST priming

BIG drain plug

Steel skids with
anti-vibration mounts



Genuine Honda
GX series

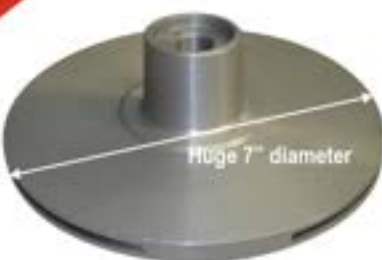

110g 7" diameter

BUY AN AUSSIE FIRE CHIEF ... BUY THE BEST!

Watch out for 3rd world chrome plated copies.
They're not Aussie's, send them back!

The biggest impeller in the business -
2.5 times heavier than competitors ...
25% more performance!

Due to our program of continuous product development the manufacturer reserves the right to alter specifications without notice.

Aussie Pumps

Reliable Products ... Reliable People



AUSSIE QUIK PRIME PETROL DRIVE FIRE FIGHTING PUMPS

The **Aussie Fire Chief**, the **Fire Captain** and "**Mr T**" super high pressure twin impeller fire pumps are regarded as the world's finest lightweight portable high pressure pumps. The Fire Chief has won significant contracts both within Australia and in export markets.

Extraordinary performance, quality components and ease of serviceability makes the Aussie Fire Chief the choice of farmers and professional fire fighting authorities around the world.

Aussie Fire Chief (QP205SE)

Designed to **out-perform** and **out-feature** all other portable fire fighting pumps, the Aussie Fire Chief offers significant quality features.

These include a huge 7" diameter, one piece impeller that weighs 2½ times more than impellers in other brands. The big belly body provides large water passages allowing more water to get through the pump and significantly aiding performance.

The pump will produce flows of up to 450 litres per minute and heads as high as 75 metres. The basic engine is a genuine Honda 5.5HP four stroke engine with oil alert, low oil protection, cast iron cylinder bore in conformance with tough international environmental emission standards. The Fire Chief comes with anti vibration mounts, steel skids and handle as standard.



Aussie Fireman (QP-2S)



Taking it's design principles from the Aussie Fire Chief, the **Aussie Fireman** is a smart choice for light use applications where the engine is not required to run continually for long periods. It uses a Honda GP series engine with 1 year engine warranty.

Aussie Fire Captain (QP205S)

The **Fire Captain** comes in the same configuration as the Aussie Fire Chief but with heavy duty steel roll frame instead of steel skids. Supplied with anti vibration mounts, the frame provides extra protection for the unit and added ease of transport.

Aussie Fire Captain Plus (QP205SL)

A big single impeller Aussie Fire Chief pump but with a 6.5HP Honda four stroke petrol engine, with oil alert and cast iron cylinder bore. Electric start options available on all models.

Standard equipment includes full heavy duty roll frame with pumps delivering up to 450 litres per minute flow, 75 metres head.



Aussie "Mr T" Twin Impeller Fire Pump (QPT-205SLT)

The Aussie "Mr T" is the final extension of development of the Aussie Fire Chief. It is a heavy duty twin impeller pump but with a difference!

The huge, closed vane dual impellers create a combination of high pressure and high flow that is unmatched, max head is 95 metres, max flow is 480 litres per minute.

The Aussie "Mr T" twin impeller range is available with 9HP or 13HP Honda four stroke engine power as standard equipment with electric start option available. "Mr T" is available with 2" x 2" ports, 2" x 3-way ports (1½", 1", 1") or with 3" x 3".

NEW Mr T 13HP electric start version now available with long range fuel tank (18 litres) ... Runs for up to 4.5 hours under load in extreme



heat.

Aussie QP305SL 3" High Pressure Pump

The 3" version of the Aussie Fire Chief, the QP305SL is available in a wide range of options that provide flows of up to 510 litres per minute and heads as high as 68 metres.

Due to our program of continuous product development the manufacturer reserves the right to alter specifications without notice.



AUSSIE QUIK PRIME PETROL DRIVE FIRE FIGHTING PUMPS ... SIZE DOES MATTER

Features

- Five year pump end warranty
- Lightweight portable
- Fast self priming from 7.6 metres
- Replaceable flanged suction port cover and discharge elbow
- Honda four stroke GX series petrol engines (3 year warranty). The Honda GP series engine carries a 1 year warranty
- Skids with rubber feet and carry handle as standard on Fire Chief & Fireman
- Full frame with anti vibration mounts on Fire Captain & Mr T versions (option for Fire Chief)
- Single piece, heavy duty closed impeller
- Three way outlet (2" & 3" outlet options)
- Big 2 inch inlet
- Big belly body
- Three way outlet with metal caps with chains
- Big drain port
- Big integrated priming port
- Optional Viton seal and o-ring kit

Benefits

- » Great quality ... use with confidence
- » Weighs from only 23kgs
- » Ready to pump in minimum amount of time
- » Easily replaced if thread damaged, easy to service check valve without dismantling pump
- » Tried and proven with established service networks throughout the world
- » Feet absorb vibration - stable in operation
- » Protects pump, facilitates transport on site
- » Pumps more water at high pressure, saves fuel
- » Enables choice of plumbing sizes (1" or 1 1/2")
- » Lets more water into the pump
- » Larger water passages mean more water efficiency, lower fuel costs
- » Top quality, ensures outlet cap security
- » Fast, easy pump draining
- » Facilitates fast self priming
- » Enables pump to be used in some herbicide or insecticide spraying applications



Fire Chief (QP205SE/GX160)



Applications:

- Fire fighting, mop up and general fire protection
- High pressure water transfer
- Spray irrigation
- Diesel fuel transfer (with Viton seals fitted)
- High pressure spraying
- Sheep jetting
- Boom spraying
- Stock crate wash down
- Machinery wash down

Other configurations:

- Diesel drive (Yanmar, Kubota, Hatz)
- Hydraulic drive

Specifications

Model	Engine Model	HP		Max Head (m)	Max Flow (lpm)	Suction port	Discharge ports	Self primes to (m)
Fireman (QP-2S)	GP160	5.5	Skids & handle	60	450	2"	2x1", 1x1 1/2"	7
Fire Chief (QP205SE)	GX160	5.5	Skids & handle	75	450	2"	2x1", 1x1 1/2"	7.6
Fire Captain (QP205S)	GX160	5.5	Full frame	75	450	2"	2x1", 1x1 1/2"	7.6
Fire Captain Plus (QP205SL)	GX200	6.5	Full frame	75	450	2"	2x1", 1x1 1/2"	7.6
Mr T Twin impeller (QPT-205SLT)*	GX270 or GX390	9, 13	Full frame	95	500	2"	2x1", 1x1 1/2"	7.6
QP305SL	GX160, GX200,	5.5, 6.5,	Full frame	70	450	3"	3"	7.6
3" Mr T Twin impeller	GX270 or GX390	9, 13	Full frame	95	500	3"	3"	7.6



Quality ISO 9001
SAI GLOBAL

NOTE: Aussie stock codes for QP pumps are determined by using the pump & engine model, for example QP205SL/GX200E is the 6.5HP Honda, electric start version of the QP205SL

* 13HP electric start Mr T available with the option of an 18 litre long range fuel tank

Due to our program of continuous product development the manufacturer reserves the right to alter specifications without notice.

Aussie Pumps

Reliable Products ... Reliable People



AUSSIE QUIK PRIME PETROL DRIVE FIRE FIGHTING PUMPS

Construction:

Front case	Marine grade aluminium
Volute	Marine grade aluminium
Back plate	Marine grade aluminium
Mechanical seal	Carbon/ceramic
Outlet	Marine grade aluminium
Casing bolts	Zinc plated steel
Check valve	Nitrile rubber
Priming & drain plugs	Polycarbonate
Casing, priming & drain plug o-rings	Nitrile rubber
Finish	Brushed aluminium
Impeller	Marine grade aluminium, closed type

Dimensions:

Fire Chief

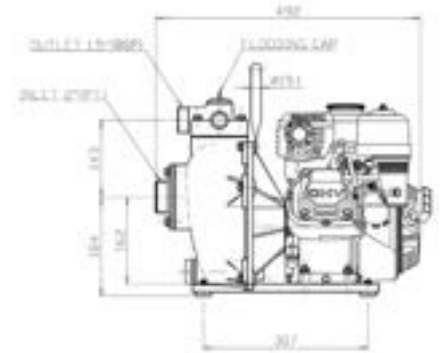
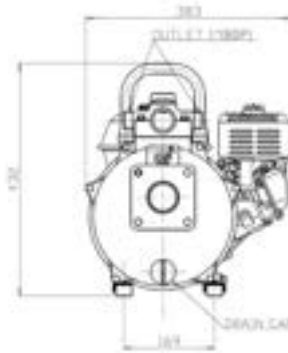

Weight: 25kg

Models with Roll Frames	Width (mm)	Height (mm)	Length (mm)	Weight (kg)
Fire Captain (QP205S/GX160)	386	460	523	32
Fire Captain Plus (QP205SL/GX200FF)	386	460	523	35
Mr T Twin Impeller (QPT205SLT/GX270)	510	610	710	57
Aussie QP305/GX200	386	460	523	35
3" Mr T Twin Impeller	510	610	710	57



Fire Captain



Mr T Twin Impeller

Performance Curve:

Golden Rule

Operate pump at the best efficiency point ... 85% of max pump head

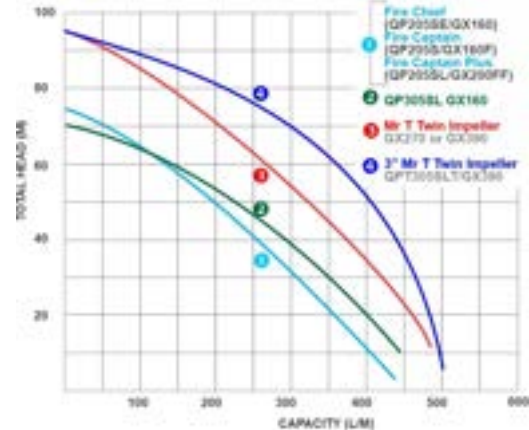
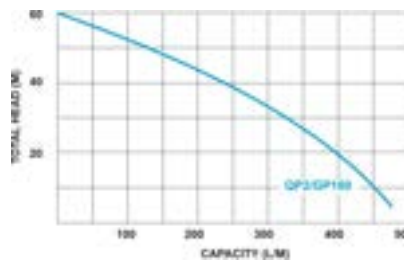

Optional Accessories:

- Heavy duty suction hose
- Fire fighting hose kits including deluxe hose kit with two 20 metre delivery hoses and fire fighting nozzles
- Storz fittings
- Coupling Kit
- Strainer
- Aussie Fire Cart for fast pump deployment



Due to our program of continuous product development the manufacturer reserves the right to alter specifications without notice.