

MP090 Centrifuge

Data sheet

MP090 centrifuges come with bowl disc technology and Bluetooth™ enabled external monitoring



Connect using the free CentriClean App



IOW Group

MP090 Centrifuge



- ◆ The MP090 has been designed for an oil sump capacity of 15 to 90 litres.
- ◆ New bowl design enables a sludge capacity of up to 0.65 litres.
- ◆ The new design also enables the oil throughput to be increased.
- ◆ Separation efficiency increases due to bowl and bowl disc design.
- ◆ Choice of MODBUS compatible and Bluetooth™ monitoring systems, that reduce maintenance costs and unnecessary cleaning.
- ◆ The MP090 has been designed to be fully interchangeable with current products on the market. This means it will fit with existing mountings without any modifications being required.

- ◆ Faster bowl speed than any existing market products. This increases centrifugal force, creating better and quicker separation.
- ◆ Optional extras are available:
 - Bespoke cut off valve pressure
 - Pneumatic assisted oil return

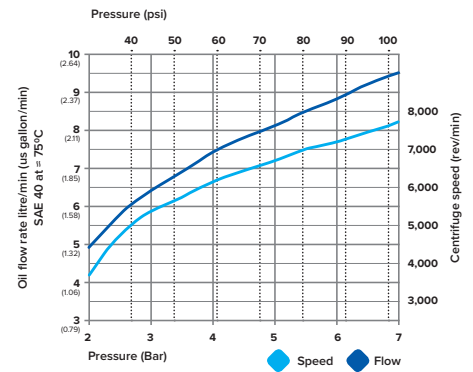
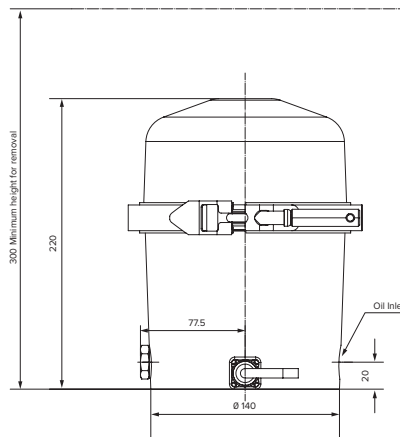
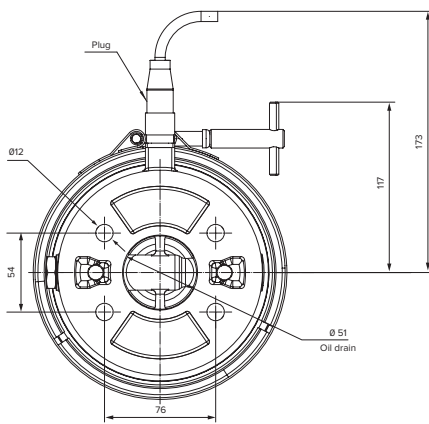

Oil Inlet - Standard 3/8" B.S.P. & 1/2" N.P.T. (others available on request)

Fixing Holes - 12mm diameter

C.O.V. (Bar) - 1.3 / 2.4

Advantages

- ◆ Reduction in engine wear
- ◆ Reduction in use of lubricating oil
- ◆ Aids clean combustion for reduced exhaust emissions
- ◆ Saves man hours in cleaning
- ◆ Reduced waste disposal costs
- ◆ Simple to operate and maintain
- ◆ Same day dispatch available on all spares
- ◆ Extends service intervals
- ◆ Extends life of full flow filters
- ◆ Capital cost investment returned quickly
- ◆ Environmentally friendly

Markets

- ◆ Marine and power
- ◆ Automotive
- ◆ Trains, trucks & buses
- ◆ Agriculture
- ◆ Mining
- ◆ Construction
- ◆ Defence

 **Find out more...**
visit IOWGroup.com

