

Double-Acting High Tonnage Cylinders - DRC series

Doc. : L1019A Date : 2018/12

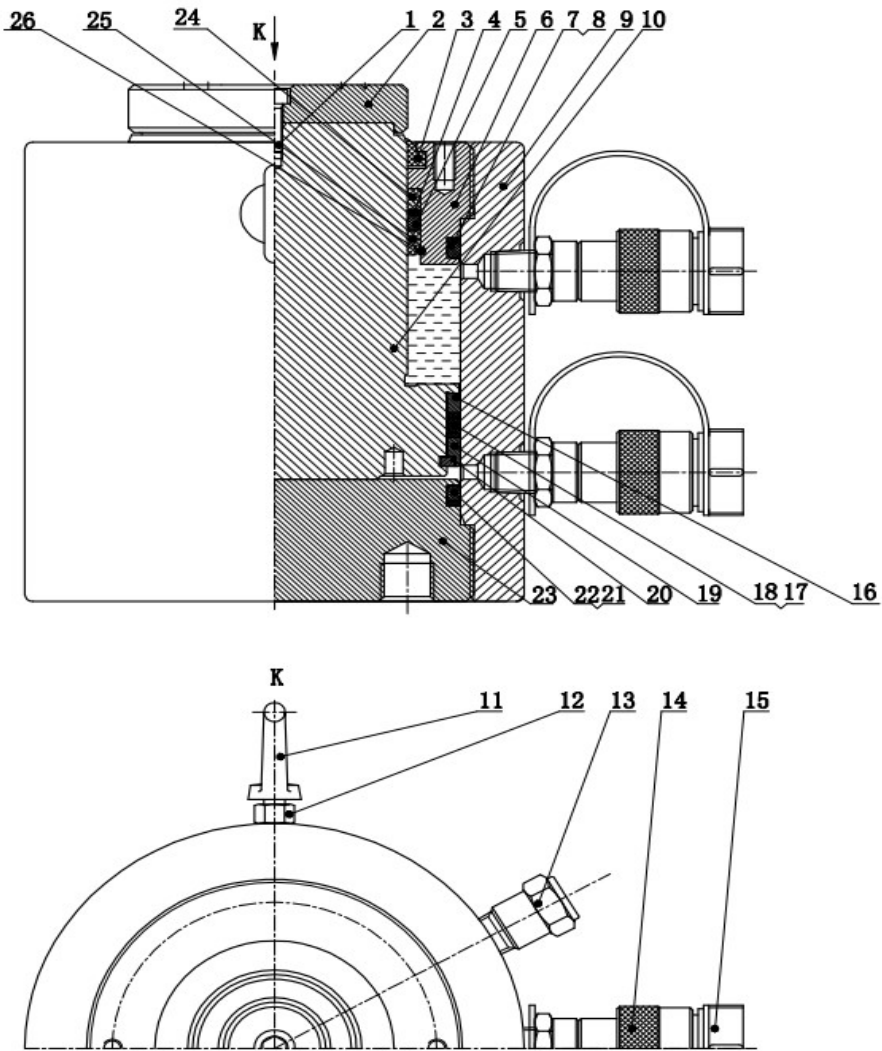

v

Item NO.	Description	Qty	Part NO.		
			DRC800-100	DRC800-200	DRC800-300
1	Hexagon socket head cap screws	1	-		
2	Lifting head (Item #1 included)	1	2.001.00098		
3	J-dustband	1	●		
4	Backup Washer	1	●		
5	O-ring	1	●		
6	Guide cap	1	2.001.00043		
7	Backup Washer	-	-		
8	O-ring	-	-		
9	Oil cylinder	1	2.001.03347 (DRC800-100)		
		1	2.001.00283 (DRC800-200)		
		1	2.001.03349 (DRC800-300)		
10	Piston rod	1	2.001.03348 (DRC800-100)		
		1	2.001.00162 (DRC800-200)		
		1	2.001.03350 (DRC800-300)		
11	Lifting bolt (Item #12 included)	2	1.3.009.00003		
12	Hexagon nut	2	-		
13	Safety valve	1	2.008.00047		
14	Female connector	2	1.3.025.00004		
15	Connector protective jacket for NPT3/8"	2	1.3.097.00002		
16	Front guide sleeve	1	2.001.00061		
17	Backup Washer	2	●		
18	O-ring	1	●		
19	Back guide sleeve	1	2.001.00060		
20	Semi-ring	1	2.001.00016		
21	Backup Washer	1	●		
22	O-ring	1	●		
23	Bottom cap	1	2.001.00071		
24	Front Guide ring	1	2.001.00058		
25	Back Guide ring	1	2.001.00059		
26	Round wire snap rings	1	1.3.112.00001		
●	Repair kit	1	DRC800-RK		