

This manual provides quick reference instructions for installing and operating the pull side 5800 door operator. Prior to performing these instructions thoroughly review the following information in document number 700002, "5800 Series Low Energy Operator Installation and Operating Instructions."

- System Description
- Prerequisites
- Precautions
- Controls and indicators
- Installing the optional plug-in transformer
- Installing the push button switches
- Linking the RF push pulbuttons
- Troubleshooting recommendations
- Detailed operator programming instructions
- Replacing the battery pack fuse
- Customizing the operator settings
- Installing door decals
- Detailed closeout instructions
- Wiring
- Replacement parts
- Adjusting door spring tension

To obtain the latest manual and template revisions or to view installation and programming videos go to www.NortonRixson.com. For technical support call 877-974-2255 ext. 2.

TABLE OF CONTENTS

1.	Installing the Operator Mounting Template.....	3
2.	Mounting the Door Shoe.....	4
3.	Installing the Operator Mounting Bracket and Cover.....	5
4.	Installing the Door Operator.....	6
5.	Installing the Door Arm.....	7
6.	Installing the Optional Plug-In Transformer.....	8
7.	Programming the Operator.....	10
8.	Initializing the Remote Control.....	11

1 Installing the Operator Mounting Template

If the door is an aluminum storefront door, EXAMINE the top rail and, when drilling the mounting holes, ENSURE the following:

- Do not drill into the top rail web
- Do not drill into the rail-to-stile tie rod(s)
- Do not drill into the rail-to-stile junction

Refer to Figure 1, and ALIGN the operator mounting template to the centerline of the butt hinge, center pivot, or offset pivot as applicable.

ALIGN LINE ON TEMPLATE
WITH BOTTOM OF FRAME

ALIGN LINE ON TEMPLATE
WITH BOTTOM OF FRAME

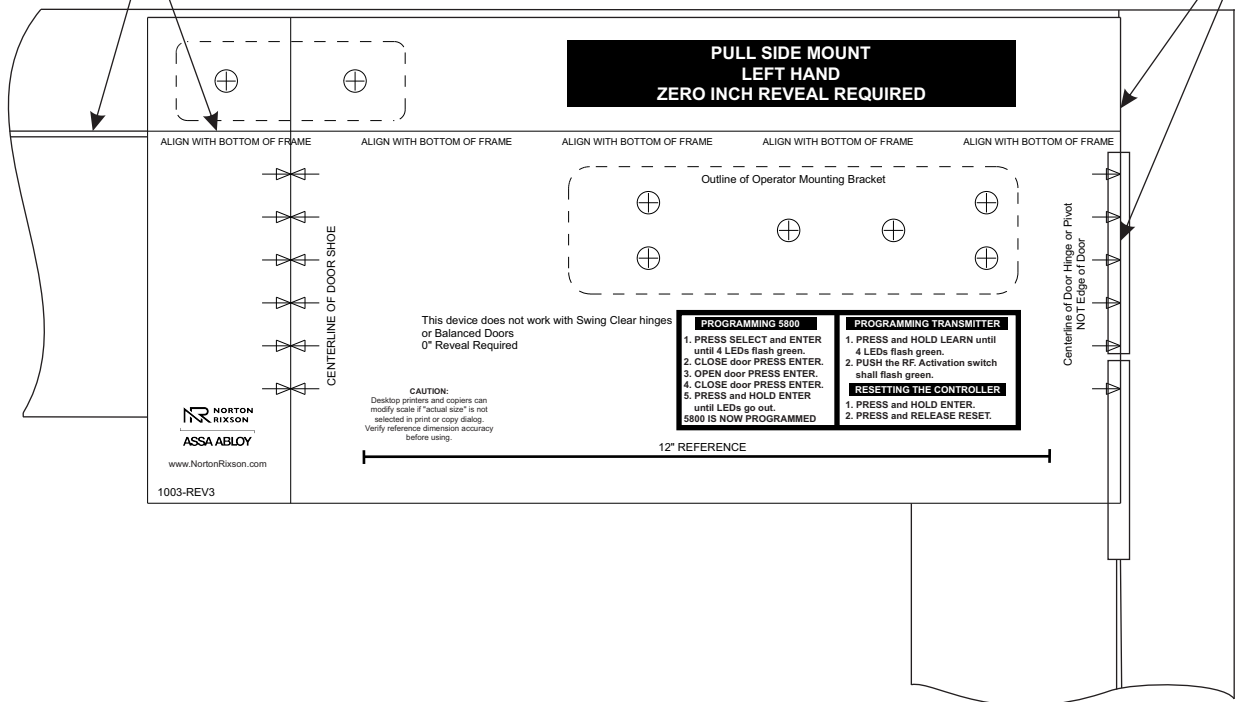

Figure 1

2 Mounting the Door Shoe

If the door frame is steel or aluminum and rivnuts must be installed, refer to Figure 2 and PERFORM the following:

- Using a 25/64" drill, DRILL the door arm pivot bracket holes.
- Using a rivnut tool, INSTALL the 1/4-20 steel rivnuts.
- INSTALL and TIGHTEN the two (minimum) 3/4" socket head capscrews with washers) securing the door arm pivot bracket to the underside and face of the frame header.

If the door frame is wood, refer to Figure 2 and PERFORM the following:

- Using a 5/32" drill, DRILL the door arm pivot bracket pilot holes.
- INSTALL and TIGHTEN the three #14 x 1 1/4" wood screws (minimum) securing the door arm pivot bracket to the underside and face of the frame header.

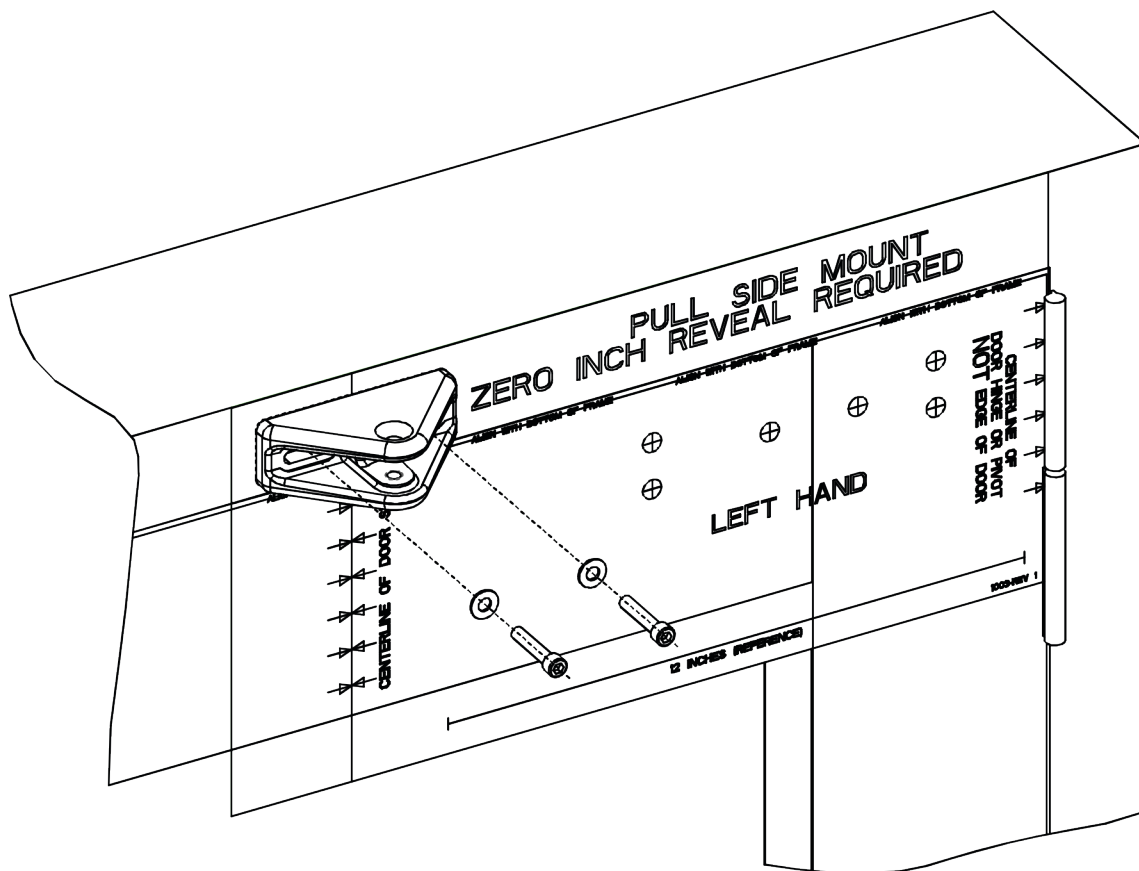

Figure 2

3 Installing the Operator Mounting Bracket and Cover

CAUTION

For light-duty or hollow-core doors with insufficient top rail blocking, through bolts or sex nut and bolts are required to securely attach the operator mounting bracket.

To ensure proper installation, the operator must be fastened with **at least** four fasteners. For heavier doors more fasteners are recommended.

If door is aluminum and rivnuts must be installed, refer to Figure 3 and PERFORM the following:

- a. Using a 25/64" drill, DRILL the mounting bracket holes.
- b. Using a rivnut tool, INSTALL the 1/4-20 steel rivnuts.
- c. INSTALL and TIGHTEN the four (minimum 3/4" socket head capscrews with black oxide washers) securing the operator mounting bracket.

If door is wood, refer to Figure 3 and PERFORM the following:

- a. Using a 5/32" drill, DRILL the mounting bracket pilot holes.
- b. INSTALL and TIGHTEN the four #14 x 1 1/4" wood screws (minimum) securing the operator mounting bracket.

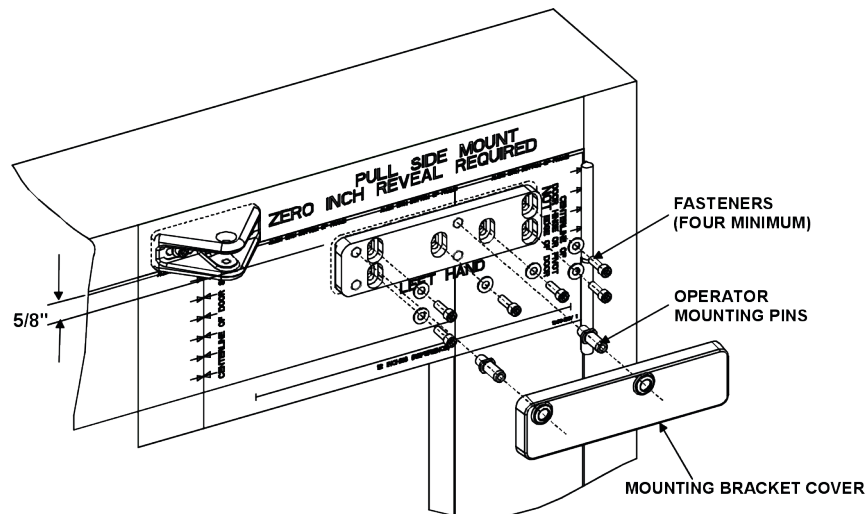

Figure 3

1. ADJUST the bracket so that there is a 5/8" (16mm) space between the top of the bracket and the top of the door.
2. TIGHTEN the socket head capscrews securing the mounting bracket to the door.
3. Using a 7/16" (11.112mm) box wrench or large adjustable wrench, TIGHTEN the operator mounting pins into the upper threaded holes in the mounting bracket.
4. INSTALL the operator mounting bracket cover over the operator mounting bracket.

4 Installing the Door Operator

WARNING

To avoid inadvertent activation of the operator during connection of the door arm, the battery pack should not be installed until after the door arm is connected.

1. REMOVE the dress cover from the operator.
2. Refer to Figure 4, and, with the battery pack facing the jamb, POSITION the operator onto the operator mounting pins. ENSURE operator does not slide off the mounting pins.
3. INSTALL and TIGHTEN the two ¼-20 X 1½" socket head capscrews securing the operator to the operator mounting pins.

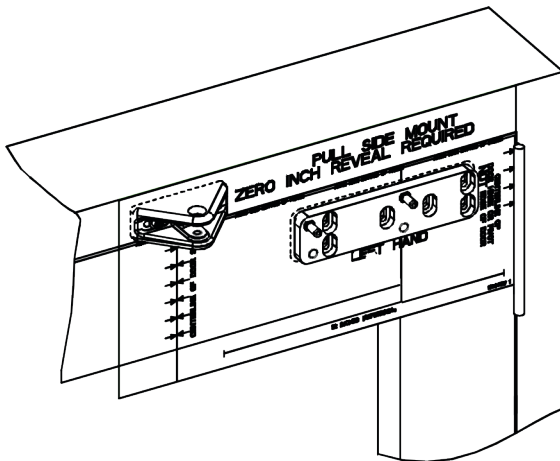
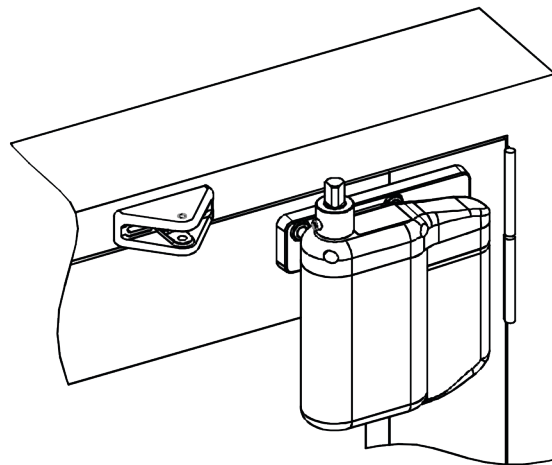

Figure 4



5 Installing the Door Arm

1. Refer to Figure 5, and **INSTALL** shaft extension onto operator shaft.
2. **TIGHTEN** set screw securing shaft extension to operator shaft.
3. Refer to Figure 6, and **ADJUST** door arm length to 8-1/16" (204.77 mm).
4. Refer to Figure 7, and, with the door arm coupling screws facing up, **POSITION** the larger end of the door arm onto the operator output shaft.

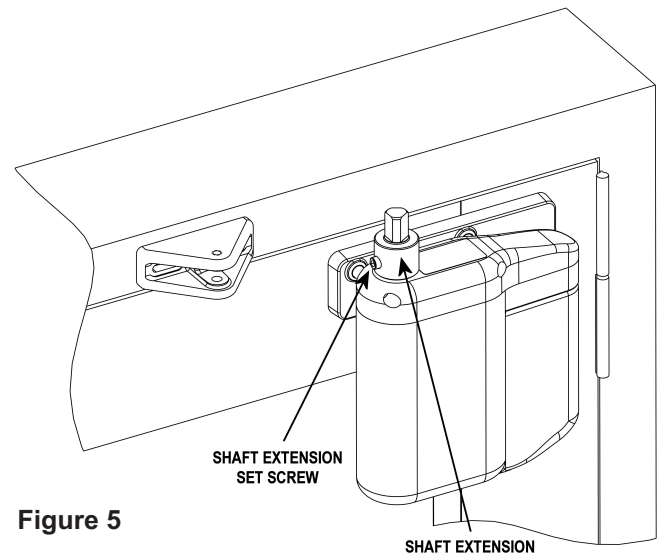

Figure 5

CAUTION
The door arm coupling is a two-piece tapered coupling. To draw the coupling halves together evenly the three door arm coupling screws must be tightened evenly (one quarter turn at a time) until fully tight.

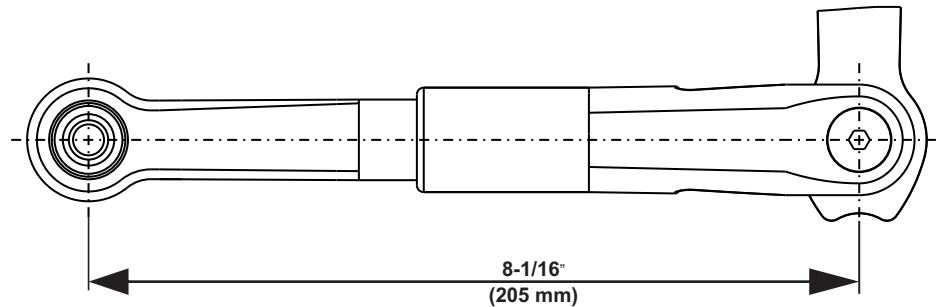

Figure 6

5. While maintaining the door arm position, **TIGHTEN** the door arm coupling screws evenly (one quarter turn at a time) until fully tight.
6. **INSTALL** the 5/16 – 18 flat head screw into the door shoe mounting bracket to secure the door arm.
7. **CYCLE** the door several times, and **ENSURE** that the door opens and closes smoothly.
8. **SLIDE** the dress cover onto the operator.
9. **CONNECT** the battery pack connector plug to the operator.
10. **SLIDE** the battery pack onto the operator, and **ENSURE** that the battery pack wires will not interfere with the operator cover.

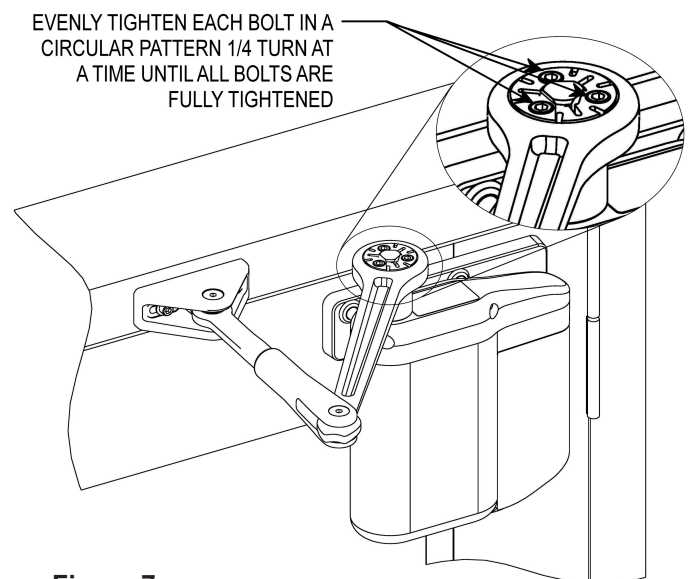

Figure 7

6 Installing the Optional Plug-In Transformer

NOTE

If possible, the transformer wiring should be routed against the door trim molding.

1. ROUTE transformer wiring to a 110-VAC outlet, but do not plug transformer into the outlet.

NOTE

An optional plug-in transformer is recommended in installations where the automatic door-opening feature will be used frequently. The optional plug-in transformer is **REQUIRED** for installations where Power Close and/or Push & Go features are enabled.

2. Refer To Figure 8, and ROUTE wires through armored cable end links. MOUNT the door cord end links as follows:
 - MOUNT one end link in the area behind or next to the battery pack.
 - MOUNT the other end link on or next to the door frame.

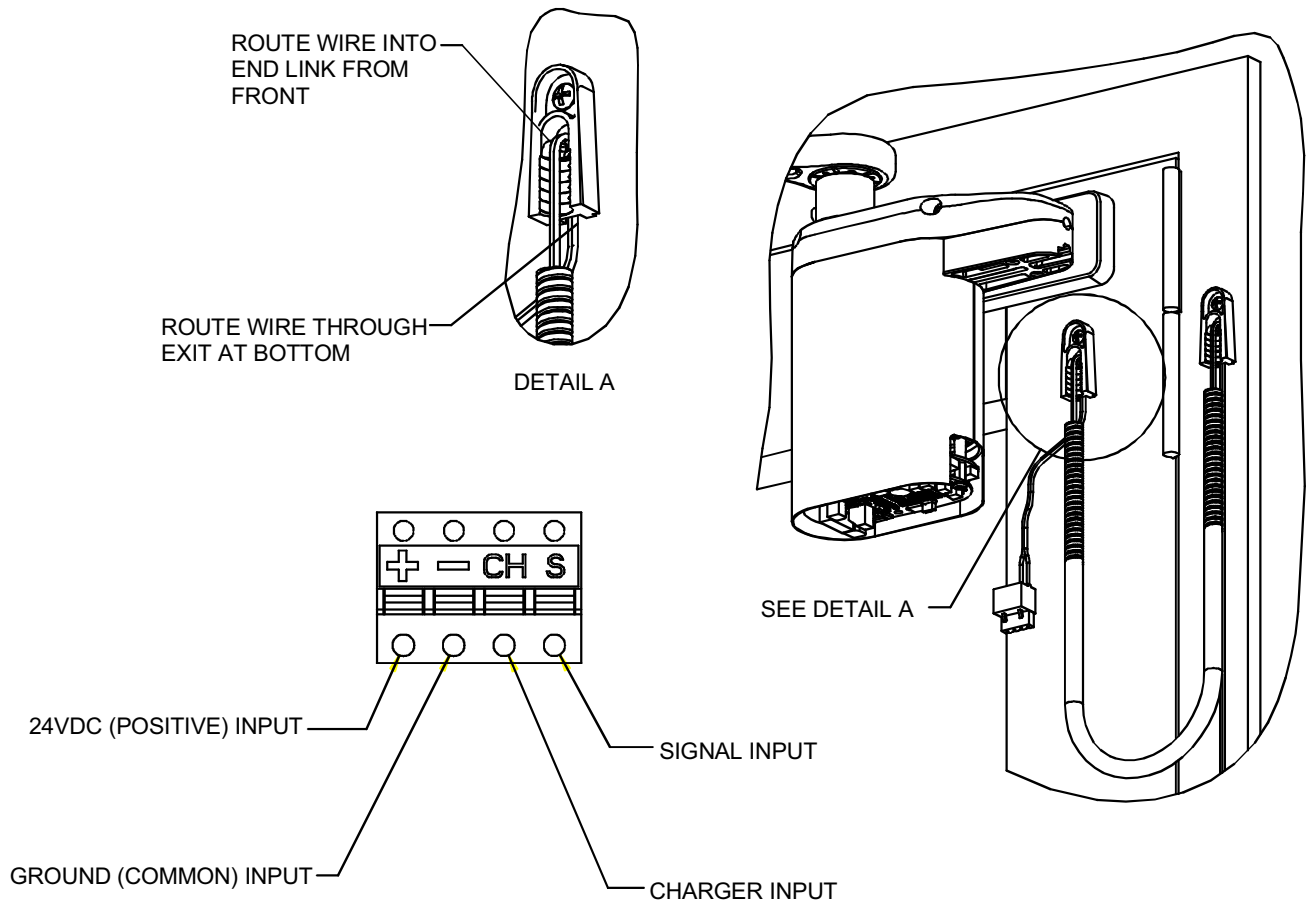

Figure 8

6 Installing the Optional Plug-In Transformer con't

3. Refer to Figure 9, and PLUG connector into receptacle on battery pack.

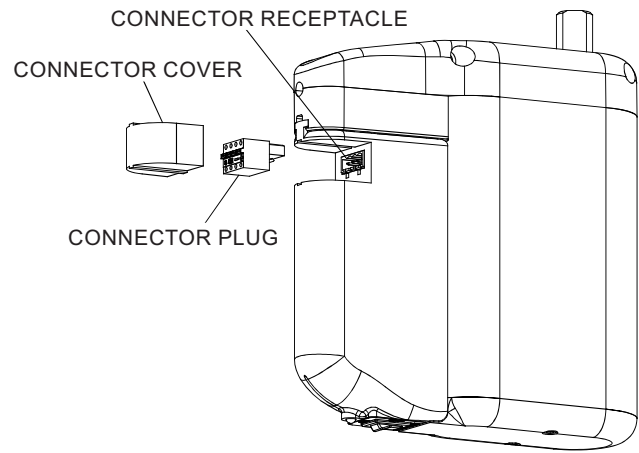

Figure 9

4. Refer to Figure 10, and VERIFY that the LED indicator lights GREEN.

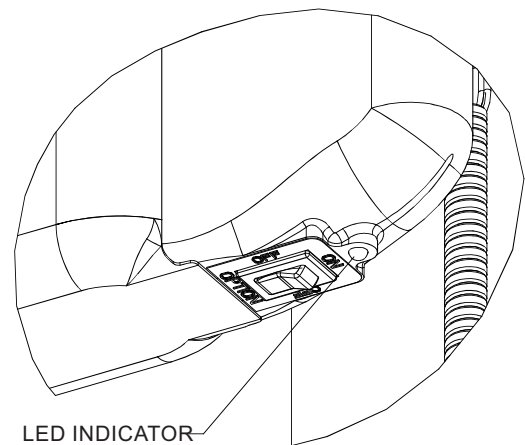

Figure 10

5. Refer To Figure 11, and INSTALL receptacle cover onto battery pack.

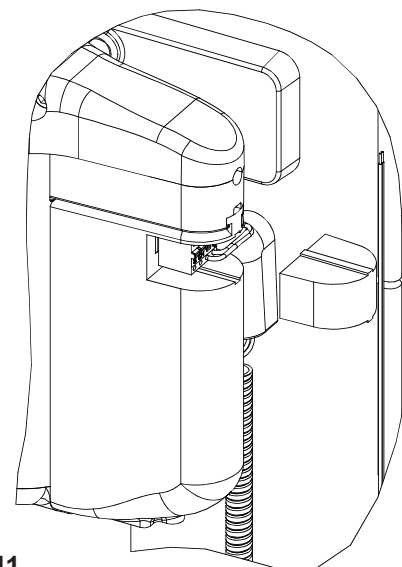

Figure 11

7 Programming the Operator

1. Refer to Figure 12 and, at the base of the setup board, PRESS and HOLD both “SELECT” and “ENTER” push buttons until LEDs 1 through 4 flash. The following shall occur:
 - The operator shall enter program mode.
 - The “CLOSE POSITION” LED shall illuminate red and remain lit.
2. With the door in the closed position, PRESS and RELEASE the “ENTER” push button. The following shall occur:
 - The “CLOSE POSITION” LED shall flash green briefly.
 - The “OPEN POSITION” LED shall illuminate red.
3. With the door in the fully open position, PRESS and RELEASE the “ENTER” push button. If the ENTER button is not accessible with the door in the fully open position, PRESS and RELEASE one of the activation push buttons. The following shall occur:
 - The “OPEN POSITION” LED shall flash green briefly.
 - The “AUTO SETUP” LED shall illuminate red.
4. With the door in the closed position, PRESS and RELEASE the “ENTER” push button. The following shall occur:
 - The door shall rapidly open 30 to 45 degrees and then close.
 - The “AUTO SETUP” led shall illuminate green.
 - The Operator will exit programming mode.
5. If further door adjustments are desired or optional features will be enabled refer to Section 11, and PERFORM adjustments.
6. To reset the controller, PERFORM the following:
 - PRESS and HOLD the “ENTER” button,
 - While holding down the “ENTER” button PRESS and RELEASE the “RESET” button.
 - LEDs 1 through 4 shall flash green briefly

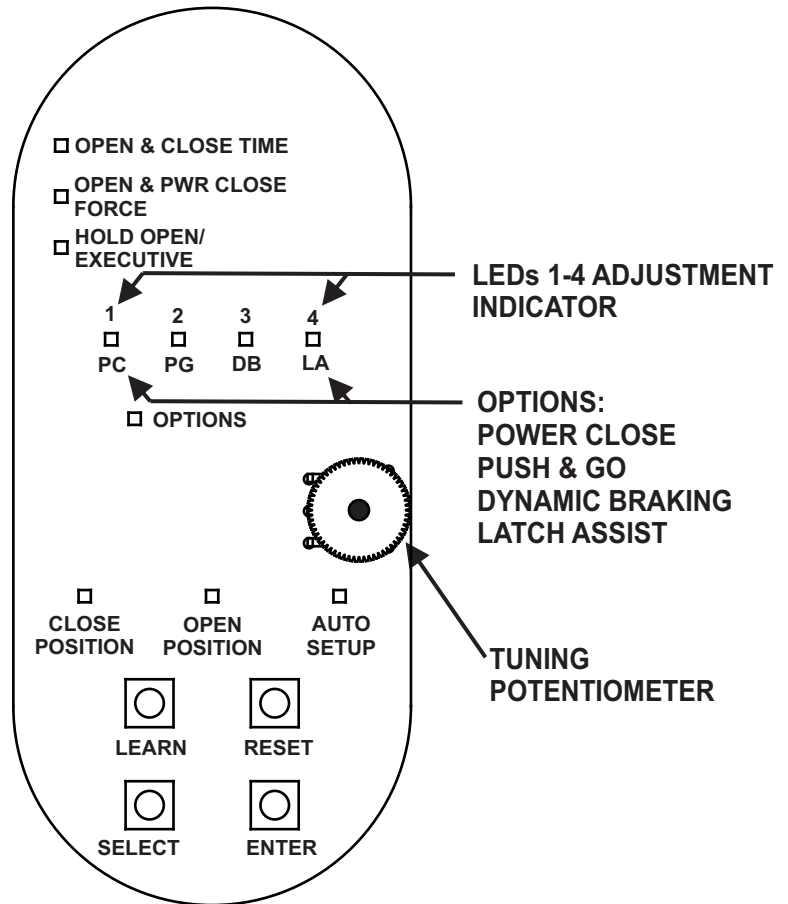

Figure 12

NOTE: Resetting the controller does not reset the RF transmitters.

The ASSA ABLOY Group is the global leader in access solutions. Every day we help people feel safe, secure and experience a more open world.

8

Initializing the Remote Control

1. To link an RF switch with a door controller, PERFORM the following:
 - a. PRESS and HOLD the “LEARN” push button on the controller until LEDs 1 through 4 flash green. The controller shall remain in the learn mode for 20 seconds or until the RF signal is received.
 - b. PUSH the RF push button. CLOSE POSITION LED shall flash green indicating that the operator accepted this RF push button.
 - c. REPEAT steps a. and b. as necessary for up to eight 5800 transmitters.
2. To remove all RF push buttons from memory, PERFORM the following:
 - a. While pressing and holding the “LEARN” push button on the controller, PRESS and RELEASE the “RESET” push button.

Technical Product Support:
Monroe, NC 28112 USA
Phone: 877.974.2255 ext: 2
Techsupport.NortonRixson@assaabloy.com
NortonRixson.com

Copyright © 2018, 2024, ASSAABLOY Accessories and Door Controls Group, Inc. All rights reserved. Reproduction in whole or in part without the express written permission of ASSAABLOY Accessories and Door Controls Group, Inc. is prohibited.

700302-Rev F 05/24

Approved 2024-05-16¹¹ of 11

Experience a safer
and more open world