



ENGINEERING SERVICES & SUPPLIES PTY LTD

Ph: 1800 074 446 www.esseng.com.au

Static Brush Conveyor Belt Cleaner

Installation, Operation & Maintenance Manual

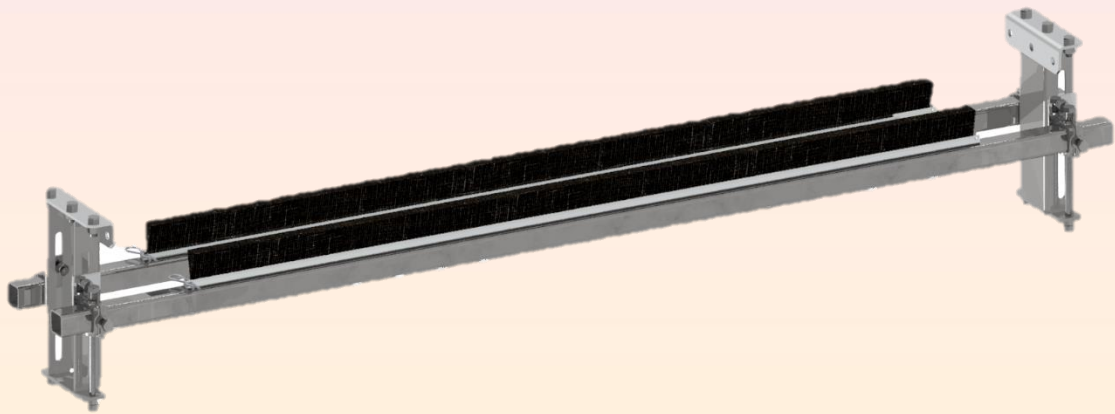



Location	Address	Phone & Email
CURRUMBIN	11 – 13 Traders Way PO Box 121 Currumbin QLD 4223	(07) 5589 2000 esscur@esseng.com.au
GLADSTONE	Shed 2, 4 Helen Street PO Box 1475 Clinton QLD 4680	(07) 4972 3759 essgla@esseng.com.au
KALGOORLIE	Unit 1 / 182 Boulder Road Kalgoorlie WA 6430 PO Box 10471 Kalgoorlie WA 6433	(08) 9021 7991 esskal@esseng.com.au
KARRATHA	26 Midas Road Malaga WA 6090	(08) 9248 4111 esskar@esseng.com.au
MACKAY	1 Progress Street Paget, QLD 4740 PO Box 5755 Mackay Mail Centre QLD 4741	(07) 4952 4600 essmac@esseng.com.au
MAITLAND	Unit 2 Barton Court 6 Johnson Street Maitland NSW 2320	(02) 4932 3544 essmai@esseng.com.au
PERTH	26 Midas Road Malaga WA 6090	(08) 9248 4111 essper@esseng.com.au
TOWNSVILLE	Unit 4/ 585 Ingham Rd Mt St John Townsville QLD 4818	(07) 5589 2032 esstow@esseng.com.au
VICTORIA	Unit 4 / 238 Governor Road Braeside VIC 3195	(03) 9587 3979 essvic@esseng.com.au
WOLLONGONG	Unit 1 / 20 Doyle Avenue PO Box 343 Unanderra NSW 2526	(02) 4272 4422 esswol@esseng.com.au
TOLL FREE 1800 074 446 FROM ANYWHERE IN AUSTRALIA		



WARRANTY

ESS WARRANTS the **Static Brush Conveyor Belt Cleaner** to be free of defects both in materials and workmanship for a period of 12 months from the date of despatch of the product from the **ESS** factory. The warranty given by **ESS** in this regard will extend only to replacing or repairing product shown to be defective.

The warranty also is subject to the following restrictions:

- (a) Installation of the product contrary to the instructions contained in the supplied manual will void such warranty absolutely;
- (b) The warranty will not extend to any liability for injuries incurred and which result from the use of the product contrary to the instructions in the manual;
- (c) Save as prescribed by law, **ESS** will not be liable for any damage sustained by a purchaser or a third party by way of consequential loss arising out of defects in the product.

You are asked to note that **ESS** offers purchasers a service whereby either:

- (a) It will install the product and certify the correctness of such installation, or
- (b) Certify the correctness or otherwise of the installation of the product by third parties.

This certification service is designed to ensure that you obtain the full benefit of the **ESS** warranty hereby provided. If you would like to take advantage of the installation certification service provided, please contact **ESS** regarding the service.

Visit the **ESS** website www.esseng.com.au to register your product warranty.

THE CONTENTS OF THIS MANUAL ARE COPYRIGHT TO:

ESS ENGINEERING SERVICES AND SUPPLIES PTY LTD
ALL RIGHTS RESERVED

Information contained herein is for use in the operation of the **Static Brush Conveyor Belt Cleaner**, purchased from **ESS** and cannot be passed on to any other party without express permission, in writing, from **ESS**.



CONTENTS

1.0 SAFETY	5
1.1 SAFETY LABELS	6
2.0 INTRODUCTION	7
3.0 PREPARATION FOR INSTALLATION	8
4.0 INSTALLATION AND SET-UP	9
4.1 INSTALLATION ON ENCLOSED CHUTE	9
4.2 INSTALLATION ON OPEN STRUCTURE	11
5.0 FAULT FINDING	13
6.0 MAINTENANCE PROCEDURE	14
6.1 ROUTINE INSPECTION AND ADJUSTMENT	14
6.2 BRUSH REPLACEMENT	14
7.0 DRAWING AND PARTS LIST	16
F0361 STATIC BRUSH CLEANER ASSEMBLY	16
8.0 FINAL CHECKLIST	17
9.0 NOTES	18

FIGURES

Figure 1 - Installation Positions	9
Figure 2 - Adjustments	11
Figure 3 - Mount Brackets	12



1.0 SAFETY

All equipment installed on or around a conveyor belt must comply with AS 1755 – 2000 Conveyors – Safety requirements.

The **Static Brush Conveyor Belt Cleaner** is designed to be quickly and easily installed and operated by appropriate personnel. Ensure that only suitably qualified and trained personnel install and service this product, and that all site and statutory safety procedures are followed.

The conveyor belt drive and any associated equipment must be shut down and locked out according to plant safety procedures before attempting work requiring access to or opening of the chute or conveyor enclosure. Contact with a moving conveyor belt and its drive components can result in serious injury or death.

The following hazards may be present when installing this equipment. Specific locations may also introduce other hazards. Ensure all hazards and potential hazards are identified and controlled.

	Hazard		Hazard
X	Moving Conveyor - ISOLATE		Other:
	Hot Work		Other:
	Stored Energy		Other:
	Working at Heights		Other:
	Heavy Lift		Other:
	Persons Working Overhead		Other:
	Persons Working Below		Other:
	Electrical & Cabling		Other:
	Pinch Points		Other:
	Trip Hazards		

Once hazards have been identified, the installer should undertake and document a comprehensive Job Hazard Analysis according to site requirements and good safe-working practice.

The installer must identify all hazards and apply appropriate controls before proceeding with the installation or servicing of this equipment.



1.1. SAFETY LABELS

Pictograph labels are used to show graphically where potential safety hazards exist around this product. These labels do not represent every possible hazard. They are not intended to be a substitute for safe work practices and good judgment. These labels and *ESS* technical manuals use specific words to identify the severity of the hazard. They are described below. Take time to read and understand the meaning of these words and symbols.



Danger labels call attention to imminently hazardous situations that will result in serious personal injury or death if not avoided. Injury from these hazards is immediate in nature and has a high probability of resulting in a serious or fatal accident if proper precautions are not followed.



Warning labels call attention to potentially hazardous situations that could result in serious personal injury or death if not avoided. Injury from these hazards is usually serious in nature, and a severe or fatal accident can occur if proper precautions are not followed.



Caution labels call attention to potentially hazardous situations that may result in minor or moderate personal injury if not avoided. Injury from these hazards is normally less serious than those from Danger or Warning hazards. However, there is still the potential for an accident resulting in serious injury if proper precautions are not followed.



2.0 INTRODUCTION

The **ESS Static Brush Conveyor Belt Cleaner** is designed to remove adhering material from the return side of a conveyor belt.

The **Static Brush Conveyor Belt Cleaner** is suitable for fine and dry powdery materials which are often difficult to scrape from the belt, such as alumina, cement, and fine sands.

The **Static Brush Conveyor Belt Cleaner** is suitable for light / medium duty applications up to a maximum belt speed of 2 metres per second. It is available as a single or dual brush unit and is suitable for use on reversing conveyors.

The **Static Brush Conveyor Belt Cleaner** should be used following a standard belt cleaning system comprising a primary and secondary cleaner, which will remove the bulk of the adhering carryback and prevent the **Static Brush Conveyor Belt Cleaner** from being overloaded.



3.0 PREPARATION FOR INSTALLATION

Familiarise yourself with the installation and operation of the **Static Brush Conveyor Belt Cleaner** before proceeding with the installation.

Ensure that suitable tools, safety equipment and safe working access are available before proceeding.

At the conveyor, select the installation position based on the following criteria:

- The **Static Brush Conveyor Belt Cleaner** should be installed within the head chute wherever possible to ensure that material removed from the belt is retained in the material circuit.
- Where the cleaner cannot be installed in the head chute, ensure that material removed from the belt is delivered to a suitable point or collected for safe removal.
- The **Static Brush Conveyor Belt Cleaner** should be preceded by a belt cleaning system comprising a primary cleaner (as a minimum) and a secondary cleaner.
- The installation position should be on a section of the conveyor that is flat (across the belt), vibration free and with safe access for inspection and service.



4.0 INSTALLATION AND SET-UP



Do not carry out any installation work around a moving conveyor. Contact with moving conveyor components can result in serious injury or death. Shut down and lock out the conveyor before attempting any work that involves entry or reaching into the conveyor operating enclosure.

4.1 INSTALLATION ON ENCLOSED CHUTE

Step 1 - At the selected installation position, mark out and cut the following holes and openings in the chute wall on each side of the conveyor.

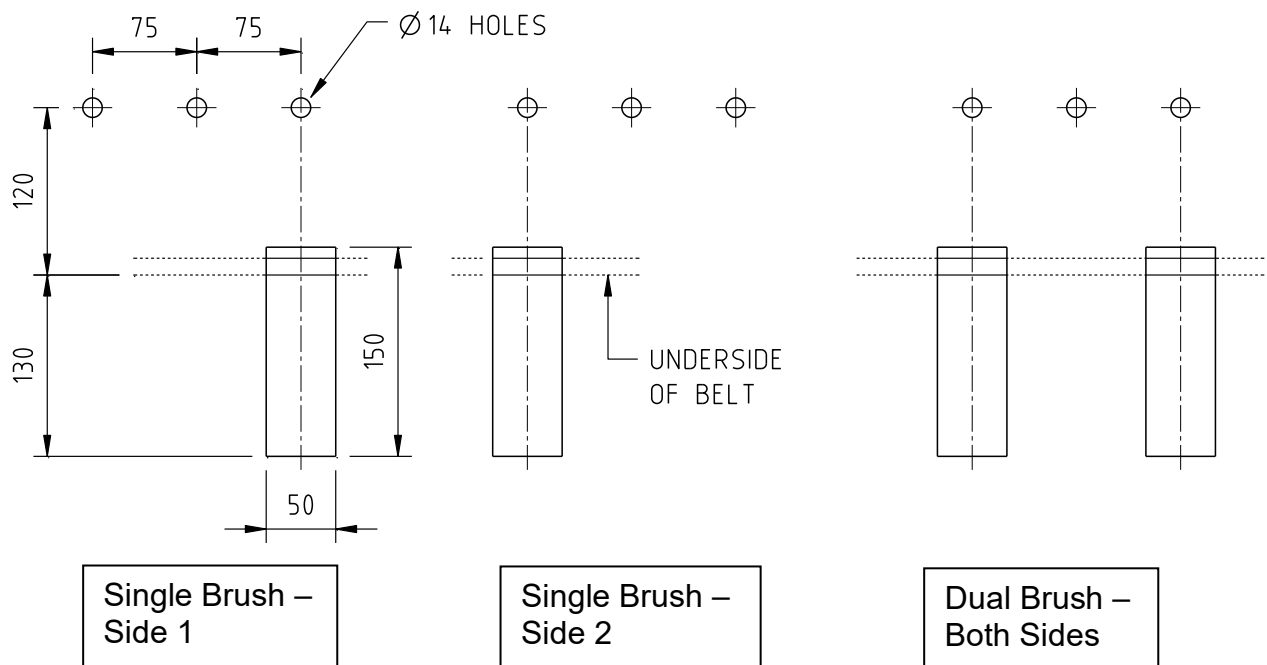

Figure 1 - Installation Positions

Note: Belt direction is not critical. The cleaner is suitable for reversing belts.

Step 2 – Remove the cleaner mainframe and brush assembly from the mount brackets by loosening the lock screw on the adjusting bracket on each mount.

Step 3 – Fit the mount brackets to the chute wall and secure using M12 bolts through the three holes in the back of the angle bracket.



Step 4 – Remove the adjusting bracket from the mount bracket on one side of the conveyor (call this the Operator side). On the other side (Far side), locate the adjusting bracket to align with the lower portion of the pre-cut opening and secure to the mount bracket.

Step 5 – Pass the brush and mainframe assembly through the opening in the Operator side and feed the end through the adjusting bracket on the Far side.

Tip: Use a longer piece of pipe or tube of a smaller section through the openings and adjusting brackets to support the mainframe during installation. The mainframe should fit over the smaller tube, and this tube can be withdrawn after the mainframe is in position.



Step 6 - Re-fit the adjusting bracket to the mount bracket on the Operator side, after first passing it over the end of the mainframe. Centre the mainframe to the belt and structure and lightly secure the lock screw on each adjusting bracket to hold the mainframe in position. The brush tips should be about 15mm below the underside of the belt at this stage.

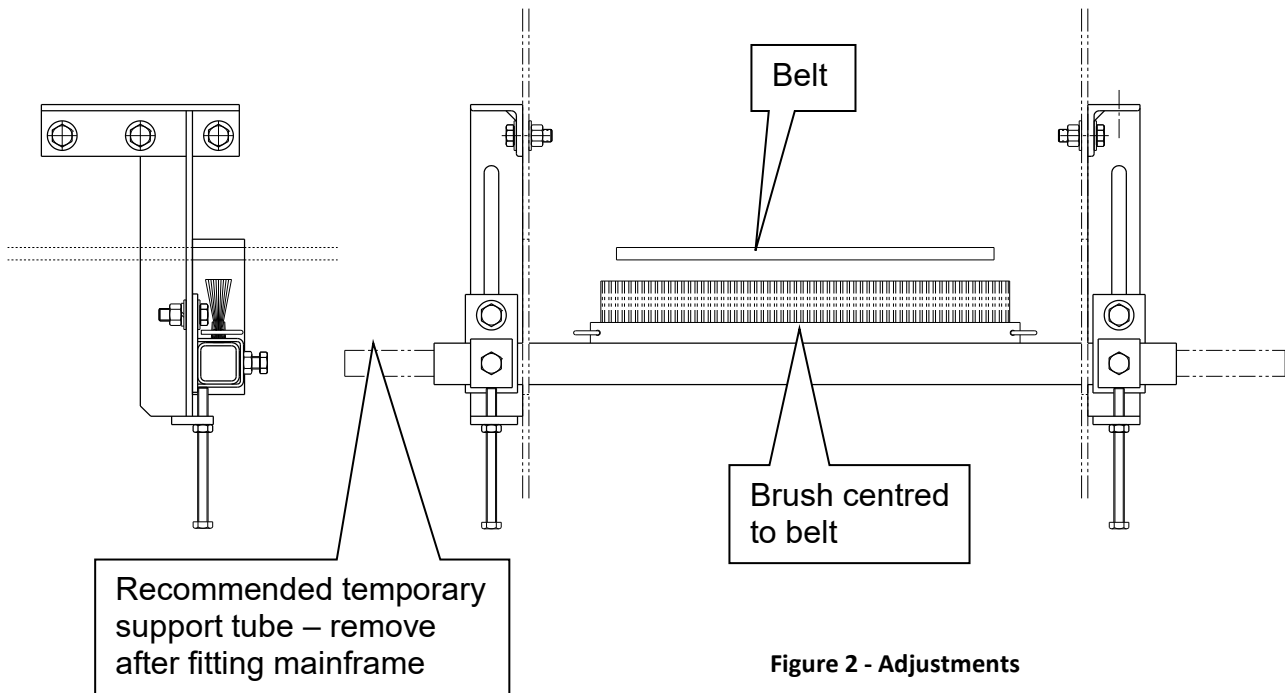

Figure 2 - Adjustments

Step 7 – Loosen the bolts attaching the adjusting brackets to the mount brackets. Loosen the locknuts on the adjusting screws. Use the adjusting screws to raise the cleaner into light contact with the belt. Ensure even adjustment both sides. Once the brush tips have just contacted the belt, apply two further rotations of the adjusting screws, and then tighten the locknuts. Do not over-adjust. Tighten the bolts securing the adjusting brackets to the mount brackets, and the lock screws to the mainframe.

Note: If the cleaner locks up during adjustment, loosen one of the lock screws only from the mainframe to allow the mainframe to end float.

The cleaner is now installed and adjusted!

4.2 INSTALLATION ON OPEN STRUCTURE

Installation of the **ESS Static Brush Conveyor Belt Cleaner** on open structure is the same as for enclosed chutes, except that no openings need to be cut and the mount brackets will attach directly to the conveyor stringer.



Before commencing installation, test fit one mount set to the conveyor stringer with a clamp. Ensure that the mainframe will be in the lower third of the bracket adjustment when the brush tips are just clear of the belt. This will be dependent on the belt height in relation to the stringers and will determine where the cleaner mounts brackets are attached – see the following diagram.

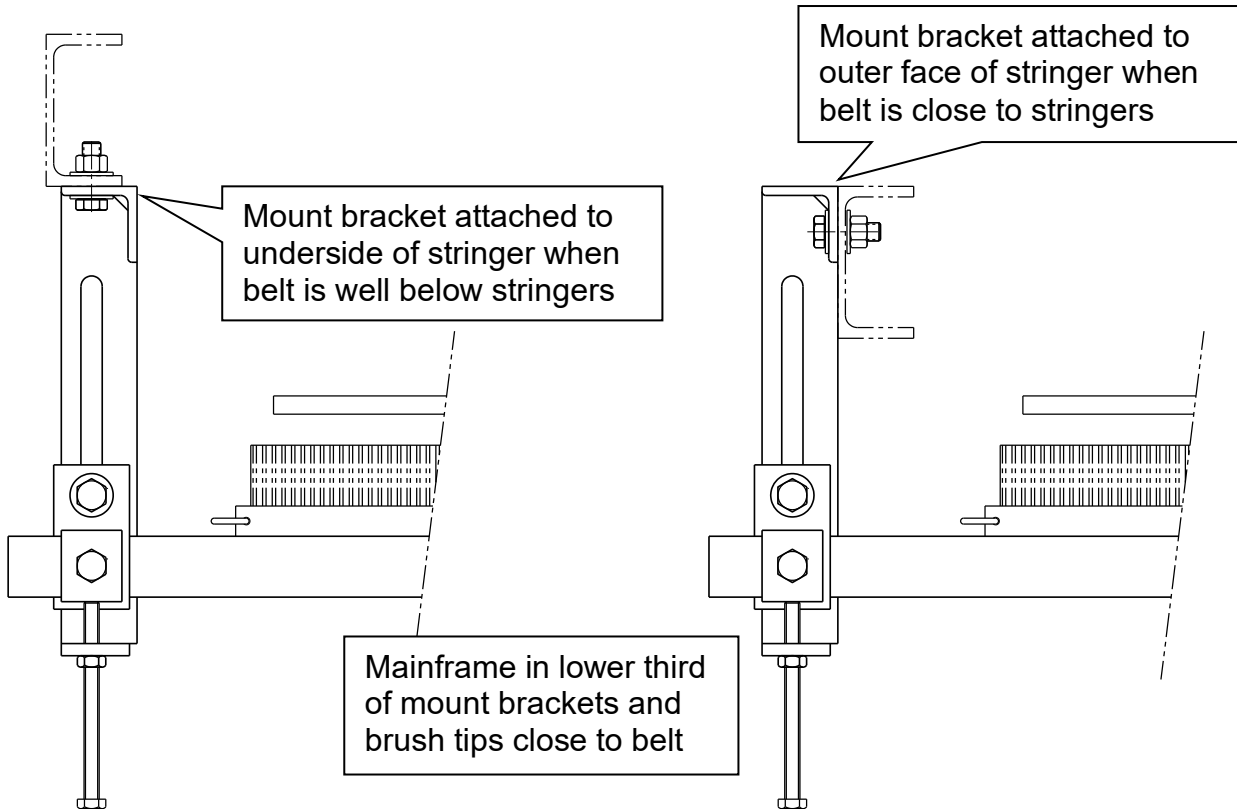

Figure 3 - Mount Brackets

Mount bracket attachment is determined by the belt height in relation to the stringers.

The **ESS Static Brush Conveyor Belt Cleaner** is now installed and ready for service.

Ensure that all installation materials, tools, and scrap are cleared from the belt. Ensure walkway is cleared and good housekeeping practices employed.

The belt may now be returned to service, following all site safety procedures.



5.0 FAULT FINDING

Fault	Action
<ul style="list-style-type: none"> • Poor cleaning • Excessive wear • Brush blinding up 	<ul style="list-style-type: none"> • Belt speed too high. Do not use on belts at speeds in excess of 2 metres per second. • Over-adjustment. Blade tips should contact the belt. Excessive adjustment will cause blades to bend over and will reduce cleaning effect as well as increase wear. • Wet material. The Static Brush Conveyor Belt Cleaner is only suitable for fine and dry powders.



6.0 MAINTENANCE PROCEDURE

6.1 ROUTINE INSPECTION AND ADJUSTMENT

The **ESS Static Brush Conveyor Belt Cleaner** should be visually inspected on a regular basis. The actual intervals will be dependent on service conditions but should be at least weekly initially. Visual inspection should be carried out with the belt running, but only if it is safe to do so. Using a torch, inspect the condition and adjustment of the brush through the chute opening, or under the stringers.

WARNING: Do not reach into the chute or past the stringers when the belt is running. Shut down and lock out the conveyor before attempting any action that requires any part of the body to enter the conveyor enclosure. Serious injury or death may result from contact with a moving conveyor.

If the brush is in serviceable condition, but requires adjustment, the following may be done with the belt running:

Loosen the bolts attaching the adjusting brackets to the mount brackets. Loosen the locknuts on the adjusting screws. Use the adjusting screws to raise the cleaner into light contact with the belt. Ensure even adjustment both sides. Once the brush tips have just contacted the belt, apply two further rotations of the adjusting screws, and then tighten the locknuts. Do not over-adjust. Tighten the bolts securing the adjusting brackets to the mount brackets, and the lockscrews to the mainframe.

6.2 BRUSH REPLACEMENT

The following procedure should be followed to replace a brush segment:

- Shut down and lock out the conveyor.
- Ensure that a replacement brush segment of the correct length is prepared and available.
- Loosen the bolts attaching the adjusting brackets to the mount brackets. Loosen the locknuts on the adjusting screws. Use the adjusting screws to lower the cleaner away from the belt.
- If available, fit a longer and smaller tube section through the mainframe to support the cleaner mainframe during withdrawal.
- Loosen the lock screws on both sides and remove the adjusting bracket from the Operator side.
- Withdraw the cleaner mainframe, taking care and being aware that it will suddenly drop away when it pulls clear of the far side bracket (the smaller tube, if used, will prevent this).
- Clean off any build-up and inspect the brush segment. Remove the retaining pin from one end and slide out the brush segment.
- Clean out the brush track and fit the new segment. Re-fit the retaining pin.



- Re-install the mainframe and brush assembly, reversing the removal steps. Lock the mainframe in place by securing the far side lock screw.
- Use the adjusting screws to raise the cleaner into light contact with the belt. Ensure even adjustment both sides. Once the brush tips have just contacted the belt, apply two further rotations of the adjusting screws, and then tighten the locknuts. Do not over-adjust. Tighten the bolts securing the adjusting brackets to the mount brackets, and the lock screws to the mainframe.
- Remove isolations and return the belt to service.



7.0 DRAWING AND PARTS LIST

F0361 STATIC BRUSH CLEANER ASSEMBLY

DO NOT SCALE. ALL DIMENSIONS ARE IN MILLIMETRES UNLESS OTHERWISE SPECIFIED. REMOVE ALL BURRS AND SHARP CORNERS

DUAL STATIC BRUSH
 150, 100, 75, 50, 75, 30, 190 MAX, 60 MIN, BRUSH = DIM 'Y', MAINFRAME = DIM 'X'

SINGLE STATIC BRUSH
 L/H SHOWN

NOTE: BRUSH SHOULD BE ADJUSTED TO HAVE A LIGHT CONTACT WITH A WELL SUPPORTED, STABLE BELT

PART No's FOLLOWED BY xxx INDICATE THAT THE PART IS AVAILABLE IN ALL STANDARD BELT WIDTHS. SUBSTITUTE xxx WITH BELT WIDTH MEASURED IN cm.

ITEM	DESCRIPTION	QTY	DUAL	DRG No.	PART No.
1	MAINFRAME L/W BRUSH	1	2	D1231	15257XXXS
1.1	STATIC BRUSH REPL. BRUSH STRIP	1	2	-	25517XXXS
1.2	CLIP 'R' GRIP 4MM SS	2	4	-	02308005S
2A	COMPACT BRUSH L/H MOUNT BRACKET	1	-	D1169	09060050LS
2B	STATIC BRUSH DUAL MOUNT BRKT SS	1	-	D1169	09060050RS
2.1	JACKING SCREW M10 x 130 S.S.	2	4	D1165	03091165S
2.2	SCREW M12x40 HEX SET 304SS	6	6	-	02315540S
2.3	WASHER M12 304SS	12	12	-	02319512S
2.4	NUT M12 HEX 304SS	6	6	-	02311512S
3	STATIC BRUSH ADJUSTING BRACKET	2	4	D1227	09060150S
3.1	SCREW M12x40 HEX SET 304SS	2	4	-	02315540S
3.2	NUT M12 HEX 304SS	2	4	-	02311512S
3.3	WASHER M12 304SS	4	8	-	02319512S
3.4	WASHER M12 SPRING 304SS	2	4	-	02319514S
3.5	SCREW M12x20 HEX SET 304SS	2	4	-	02315520S

BELT WIDTH	DIM 'X'	DIM 'Y'	SINGLE PART No.	DUAL PART No.
450	950	500	25507045s	25508045S
600	1150	650	25507060S	25508060S
750	1300	800	25507075S	25508075S
900	1450	950	25507090S	25508090S
1050	1600	1100	25507105S	25508105S
1200	1750	1300	25507120S	25508120S
1350	1950	1450	25507135S	25508135S
1500	2100	1600	25507150S	25508150S
1600	2300	1700	25507160S	25508160S
1800	2500	1900	25507180S	25508180S
2000	2700	2150	25507200S	25508200S
2200	2900	2350	25507220S	25508220S
2400	3100	2550	25507240S	25508240S

CLIENT: ESS QUEENSLAND
 LOCATION: ESS CAD

REVISIONS: REF DOCS

ISSUED BY: CHKD APPDATE: BY: BT

REPLACEMENT BRUSH ADDED: EDCR800
 DUAL BRUSH ADDED: SD GC TT RW/WT
 ADJUSTING BRACKET MOD'D: SD GC TT RW/WT

ESS ENGINEERING SERVICES & SUPPLIES
 CUSTOMER SERVICE No. 1800 074446

STATIC BRUSH CLEANER ASSEMBLY

SCALE: 1:5
 DATE: 25/10/07
 DRAWING No. F0361

REV. D

JOB No. ARF2227

REFERENCE DRAWINGS



8.0 FINAL CHECKLIST

Site: _____ Number: _____ Date: _____

Site Equipment No./Location: _____ Site Contact: _____

Completed By: _____ (Circle Yes or No Below)

1. Was equipment to ESS Specification? _____ Yes/No

Drawing No. Ref: _____ Attached? Yes/No

If No, WHY _____

Will this affect performance? Yes/No

If Yes, WHY _____

2. Was this a standard service inspection installation? Yes/No

If No, WHY _____

3. Was work carried out as per procedure and JSA? Yes/No

If No, WHY _____

4. Is equipment fit for commissioning? Yes/No

If No, WHY _____

5. Was a final inspection carried out while plant was running? Yes/No

If No, WHY _____

6. Has anything changed from previous service / inspection / installation? Yes/No

If Yes, WHAT _____

7. Is equipment performance to Client expectations? Yes/No

If No, WHY _____

ESS Signature: _____ Client Signature: _____

