



**ENGINEERING SERVICES & SUPPLIES PTY LTD**

**Ph: 1800 074 446** [www.esseng.com.au](http://www.esseng.com.au)

# Modular Impact Cradle

Installation, Operation & Maintenance Manual

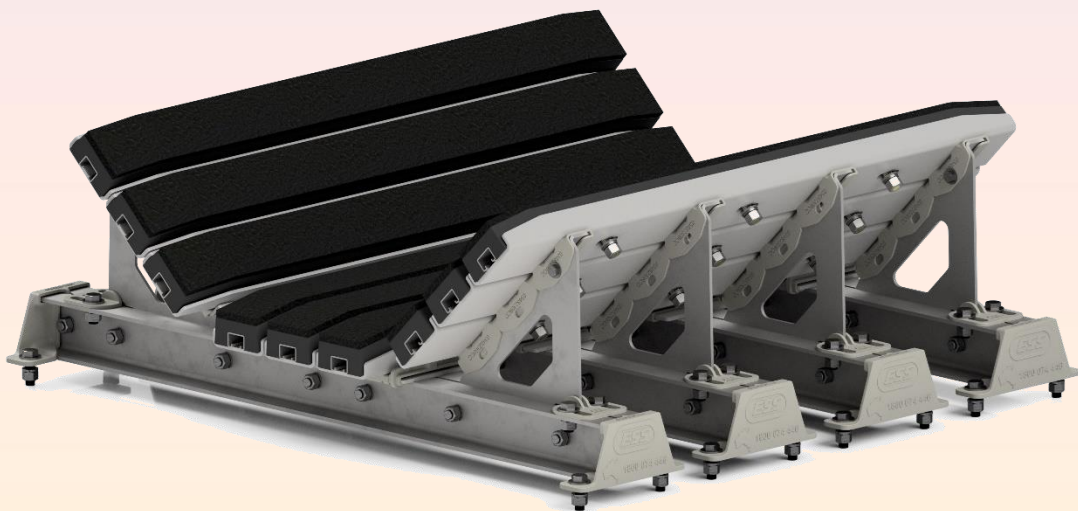



Location	Address	Phone & Email
<b>CURRUMBIN</b>	11 – 13 Traders Way PO Box 121 Currumbin QLD 4223	(07) 5589 2000 <a href="mailto:esscur@esseng.com.au">esscur@esseng.com.au</a>
<b>GLADSTONE</b>	Shed 2, 4 Helen Street PO Box 1475 Clinton QLD 4680	(07) 3924 4764 <a href="mailto:essgla@esseng.com.au">essgla@esseng.com.au</a>
<b>KALGOORLIE</b>	Unit 1 / 182 Boulder Road Kalgoorlie WA 6430 PO Box 10471 Kalgoorlie WA 6433	(08) 9021 7991 <a href="mailto:esskal@esseng.com.au">esskal@esseng.com.au</a>
<b>KARRATHA</b>	26 Midas Road Malaga WA 6090	(08) 9248 4111 <a href="mailto:esskar@esseng.com.au">esskar@esseng.com.au</a>
<b>MACKAY</b>	1 Progress Street Paget, QLD 4740 PO Box 5755 Mackay Mail Centre QLD 4741	(07) 4952 4600 <a href="mailto:essmac@esseng.com.au">essmac@esseng.com.au</a>
<b>MAITLAND</b>	Unit 2 Barton Court 6 Johnson Street Maitland NSW 2320	(02) 4932 3544 <a href="mailto:essmai@esseng.com.au">essmai@esseng.com.au</a>
<b>PERTH</b>	26 Midas Road Malaga WA 6090	(08) 9248 4111 <a href="mailto:essper@esseng.com.au">essper@esseng.com.au</a>
<b>TOWNSVILLE</b>	Unit 4/ 585 Ingham Rd Mt St John Townsville QLD 4818	(07) 5589 2032 <a href="mailto:esstow@esseng.com.au">esstow@esseng.com.au</a>
<b>SOUTH AUSTRALIA</b>	Unit 4 / 238 Governor Road Braeside VIC 3195	(03) 9587 3979 <a href="mailto:esssa@esseng.com.au">esssa@esseng.com.au</a>
<b>VICTORIA</b>	Unit 4 / 238 Governor Road Braeside VIC 3195	(03) 9587 3979 <a href="mailto:essvic@esseng.com.au">essvic@esseng.com.au</a>
<b>WOLLONGONG</b>	Unit 1 / 20 Doyle Avenue PO Box 343 Unanderra NSW 2526	(02) 4251 9801 <a href="mailto:esswol@esseng.com.au">esswol@esseng.com.au</a>
<b>TOLL FREE 1800 074 446 FROM ANYWHERE IN AUSTRALIA</b> <b>VSS TOLL FREE 1800 300 877</b>		



## WARRANTY

ESS warrants the Modular Impact Cradle to be free of defects both in materials and workmanship for a period of 12 months from the date of despatch of the product from the ESS factory. The warranty given by ESS in this regard will extend only to replacing or repairing product shown to be defective.

The warranty is also subject to the following restrictions:

- a) Installation of the product contrary to the instructions contained in the supplied manual will void such warranty absolutely.
- b) The warranty will not extend to any liability for injuries incurred and which result from the use of the product contrary to the instructions in the manual.
- c) Save as prescribed by law, ESS will not be liable for any damage sustained by a purchaser or a third party by way of consequential loss arising out of defects in the product.

You are asked to note that ESS offers purchasers a service whereby either:

- a) It will install the product and certify the correctness of such installation, or
- b) Certify the correctness or otherwise of the installation of the product by third parties.

This certification service is designed to ensure that you obtain the full benefit of the ESS warranty hereby provided. If you would like to take advantage of the installation certification service provided, please contact ESS regarding the service.

Refer to the Final Checklist at the back of this manual.

Visit the ESS website [www.esseng.com.au](http://www.esseng.com.au) to register your product warranty.

THE CONTENTS OF THIS MANUAL ARE COPYRIGHT TO:

**ESS ENGINEERING SERVICES AND SUPPLIES PTY LTD**  
**ALL RIGHTS RESERVED**

Information contained herein is for use in the operation of the Modular Impact Cradle, purchased from ESS and cannot be passed on to any other party without express permission, in writing, from ESS.



## CONTENTS

1.0 SAFETY .....	4
1.1 SAFETY LABELS .....	6
2.0 INTRODUCTION .....	7
3.0 PREPARATION FOR INSTALLATION.....	8
4.0 INSTALLATION .....	9
4.1 INSTALLATION PROCEDURE .....	9
4.2 COMMISSIONING .....	14
5.0 OPERATOR TRAINING .....	15
5.1 SERVICING .....	15
5.2 SAFETY.....	15
5.3 PROBLEMS.....	15
6.0 ROUTINE MAINTENANCE AND SERVICE .....	16
6.1 SAFETY.....	16
6.2 GENERAL .....	16
6.3 ROUTINE MAINTENANCE .....	16
6.4 CRADLE DISASSEMBLY PROCEDURE .....	16
6.5 CRADLE RE-ASSEMBLY .....	17
7.0 TROUBLESHOOTING .....	18
8.0 INSTALLATION ARRANGEMENT DRAWINGS .....	19
8.1. F0650 INSTALLATION LAYOUT .....	19
9.0 FINAL CHECKLIST .....	20
10.0 NOTES.....	21

## FIGURES

Figure 1 - Complete Impact Cradle Assembly.....	4
Figure 2 - Modular Impact Cradle Layout .....	7
Figure 3 – Lowering Down Wing Sets .....	7
Figure 4 – Sliding Out Wing Bars.....	8
Figure 5 - Sliding Out Centre Bars .....	8
Figure 6 - Cradle Positioning .....	9
Figure 7 - Cradle Setup Clearances .....	10
Figure 8 - Wing Adjustment .....	10

## TABLES

Table 1 - Hazard Checklist.....	2
---------------------------------	---



## 1. SAFETY

All equipment installed on or around a conveyor belt must comply with AS 1755 – 2000 Conveyors – Safety requirements.

Ensure that only suitably qualified and trained personnel install and service this product, and that all site and statutory safety procedures are followed.

The **ESS Modular Impact Cradle** is designed to be quickly and easily serviced by appropriate personnel, however under no circumstances should any personnel attempt installation or service of this equipment whilst the conveyor belt is running.

The conveyor belt drive and any associated equipment must be shut down and locked out according to plant safety procedures before attempting work requiring access to or opening of the chute or conveyor enclosure. **Contact with a moving conveyor belt and its drive components can result in serious injury or death.**

The individual Modular Impact Cradle Beams and Wing parts can be heavy (30-130kg) and may require installation in awkward positions. Ensure that adequate personnel are available to safely lift the Cradle parts during installation or use appropriate lifting gear.

The Modular Impact Cradle may be inspected with the belt running as long as suitable visual access is available, but **the service person should never reach into or enter the conveyor enclosure.** No other service work is able to be carried out with the conveyor running. Shut down and lock out the conveyor for any work requiring any part of the body to enter the conveyor enclosure or be exposed to moving components.

The following are some of the hazards that may be present when installing this equipment:

**Table 1 - Hazard Checklist**

	Hazard		Hazard
X	Moving Conveyor - ISOLATE		Other:
	Hot Work		Other:
	Working at Heights		Other:
	Heavy Lift		Other:
	Persons Working Overhead		Other:
	Persons Working Below		Other:
	Electrical & Cabling		Other:
X	Pinch Points		Other:
	Trip Hazards		Other:



Once hazards have been identified, the installer should undertake and document a comprehensive Job Hazard Analysis (JHA) according to site requirements and good safe-working practice. The installer must identify all hazards and apply appropriate controls before proceeding with the installation or servicing of this equipment.

## 1.1 SAFETY LABELS

Pictograph labels are used to show graphically where potential safety hazards exist around this Modular Impact Cradle. These labels do not represent every possible hazard. They are not intended to be a substitute for safe work practices and good judgment. These labels and the technical manuals supplied with the Modular Impact Cradle, use specific words to identify the severity of the hazard. They are described below. Take time to read and understand the meaning of these words and symbols.



Danger labels call attention to imminently hazardous situations that will result in serious personal injury or death if not avoided. Injury from these hazards is immediate in nature and has a high probability of resulting in a serious or fatal accident if proper precautions are not followed.



Warning labels call attention to potentially hazardous situations that could result in serious personal injury or death if not avoided. Injury from these hazards is usually serious in nature, and a severe or fatal accident can occur if proper precautions are not followed.



Caution labels call attention to potentially hazardous situations that may result in minor or moderate personal injury if not avoided. Injury from these hazards is normally less serious than those from Danger or Warning hazards. However, there is still the potential for an accident resulting in serious injury if proper precautions are not followed.



## 2.0 INTRODUCTION

The **ESS Modular Impact Cradle** consists of an adjustable steel frame, fitted with impact absorbing rubber bars that are designed to be easily removed without the removing the cradle frame from the conveyor. The bars have a low friction UHMW-Polyethylene top wear surface. The cradle is fabricated to conform exactly to the troughed belt profile.

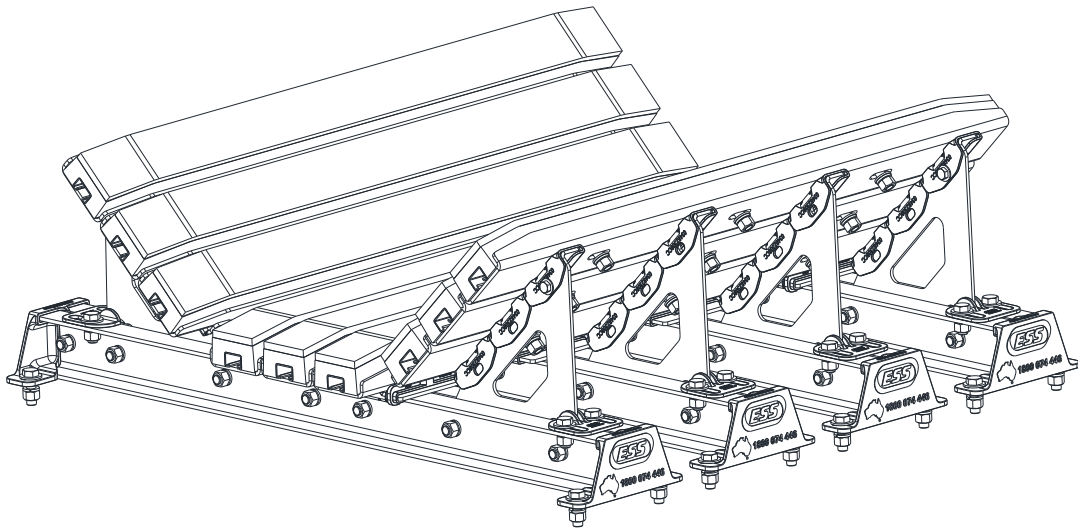

**Figure 1 - Complete Impact Cradle Assembly**

The **ESS Modular Impact Cradle** is designed to replace conventional impact idlers in the load zone of a conveyor.

Under heavy impact loading the Impact bars will easily outlast standard impact idlers, absorb shock loads, and increase belt life by reducing material piercing.

In addition to these benefits the impact bars are able to hold the belt flat under the skirting thereby virtually eliminating material spillage.

To achieve these results however, the **ESS Modular Impact Cradle** must be installed in the correct manner. Clearances and adjustments which are specified later are essential to the performance of the cradle. The cradles have been designed and manufactured to simply bolt into place on the conveyor stringers and achieve these clearances from a set of dimensions supplied by the client. The clearances should however be checked at installation to ensure that the dimensions of the cradle are correct and suitable for the conveyor/skirting.



### 3.0 PREPARATION FOR INSTALLATION

**1 Check installation drawings.**

Ensure that you have the correct drawings and equipment for your conveyor(s).

**2 Pre-assemble the Impact bars and Wing/Centre support channels.**

Do this in your workshop or similar free area, rather than at the conveyor. This will enable you to:

- ✓ Verify all required equipment is present.
- ✓ Familiarise yourself with the Modular Impact Bed assembly.
- ✓ Plan the installation and reduce installation time.

**3 Assemble the necessary tools & safety equipment required for the installation.**

**4 Observe the conveyor while running and conveying material.**

- ✓ Does the belt run true, or track off to one side?

Consult ESS if any UNUSUAL conditions are observed in the above. These conditions may result in recommendation of a different installation position or even a different Impact Cradle.



## 4.0 INSTALLATION



**IF INSTALLATION IS TO BE DONE IN AN ENCLOSED AREA, ENSURE THAT ALL CONFINED SPACE PERMITS ARE IN PLACE AND PROCEDURES FOLLOWED. IF WELDING OR CUTTING ARE REQUIRED, ENSURE THAT HOT WORK PERMITS ARE IN PLACE AND PROCEDURES FOLLOWED. PROTECT THE BELT SURFACE FROM WELD SPATTER WITH APPROPRIATE SHIELD.**

Based on the customer preferences, logistics requirements or access to the installation location the ESS Modular Impact Cradle can be shipped as a fully assembled unit or a kit of individual parts to be assembled on site. In either case the package will be sturdy and robust. It is unlikely to be damaged during normal transport and handling procedures. Each Impact Cradle assembly is despatched individually and is suitable for forklift handling. Approximate weight, depending on belt width, is of the order of 300-500kg per assembly. The units are suitable for outdoor storage on site.



**THE ESS MODULAR IMPACT CRADLE IS A LARGE AND HEAVY PRODUCT. USE HOISTING EQUIPMENT OR ENSURE ADEQUATE PERSONNEL ARE AVAILABLE TO SAFELY LIFT THE CRADLE ASSEMBLY OR INDIVIDUAL PARTS INTO POSITION.**

### 4.1 INSTALLATION PROCEDURE

- Step 1. Assemble the necessary tools and safety equipment required for the job.
- Step 2. Determine approximate installation position for each impact cradle on the conveyor and place the appropriate cradles adjacent to the installation area by use of a forklift, crane etc.
- Step 3. Before commencing installation or any work around the conveyor belt ensure that the belt is isolated and tagged.
- Step 4. The ESS Impact Cradle is intended to be installed between impact idler troughing assemblies. Multiple impact cradles will have an impact idler trough assembly between each successive cradle. Ensure that impact idler assemblies are either already installed or available at the installation site. If the idlers are already installed check that sufficient clearance is available between successive sets of rollers to fit an impact cradle. Standard impact cradles are 1200mm long and require 25mm clearance at each end between cradle bar and roller (Figure 2).

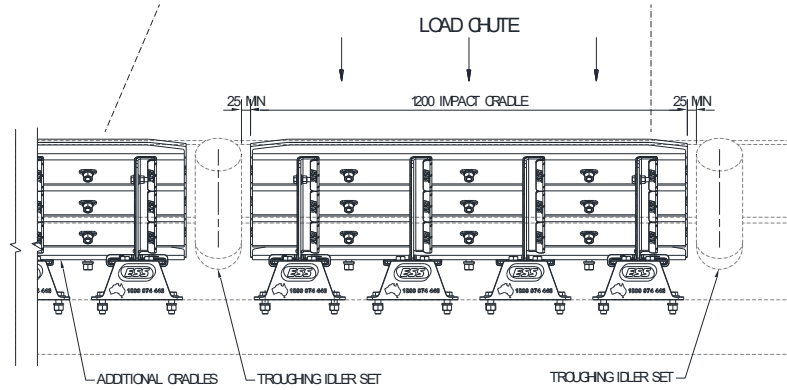

**Figure 2 - Modular Impact Cradle Layout**

- Step 5. Determine the installation position for the impact cradle/s. The impact cradle/s should be installed to cover the entire direct load area of the conveyor belt. For a short load zone this may mean one cradle and for longer load zones multiple cradles may be used. If the conveyor belt is not already in place, the cradle can be lifted complete into position and installed without disassembly. This would require crane or fork handling.
- Step 6. If the cradle is provided as a kit to be assembled on site, jump to the step 8.
- Step 7. Having determined the position of the first impact cradle, disassemble one cradle for installation. This involves removal of the outer wing bolts attaching wing part to the base (two per module) and removing the wing lock parts supporting the wings from both sides (two per module). This allows the wing sets to flip down on each side (Figure 3).

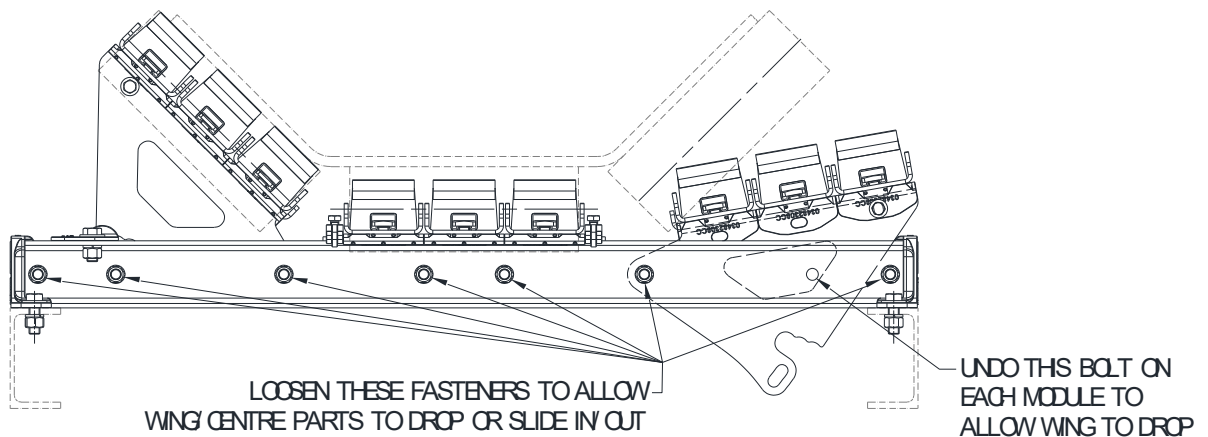
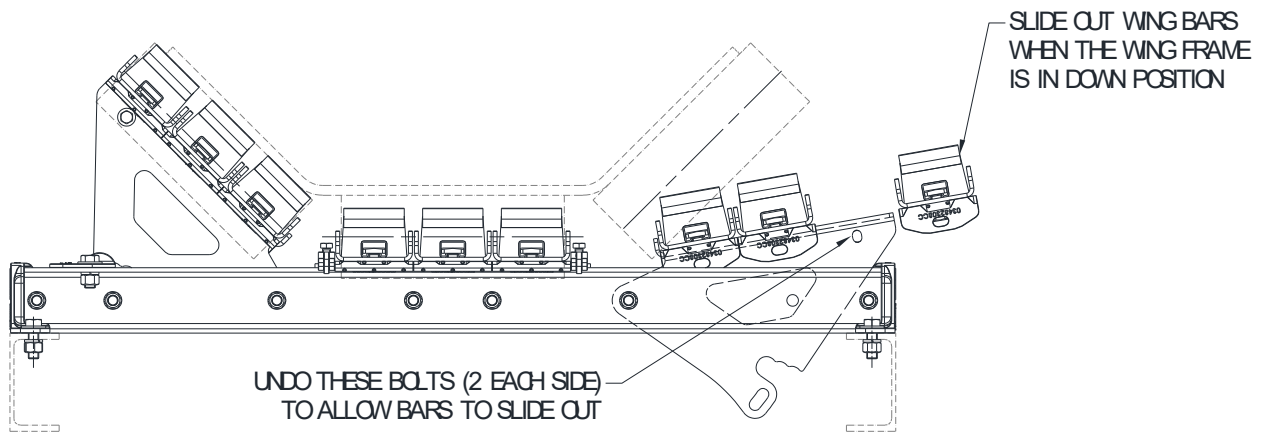

**Figure 3 – Lowering Down Wing Sets**

**CAUTION**

**DURING MOVEMENT OF THE WING LOCK PARTS AND FLIPPING UP/DOWN THE WING SETS, BE AWARE OF PINCH POINT AREAS UNDER THE WING PLATES AS THE WEIGHT OF WING SETS MIGHT CAUSE SERIOUS DAMAGE.**

After this is done the individual wing bar assemblies can be slid out from either side of the cradle by undoing the fasteners (2 per side) which lock the outer bars (Fig 4).



**Figure 4 – Sliding Out Wing Bars**

The centre bars can then be slid from the cradle base after the slide clamps are removed by undoing their securing bolts (Fig 5).

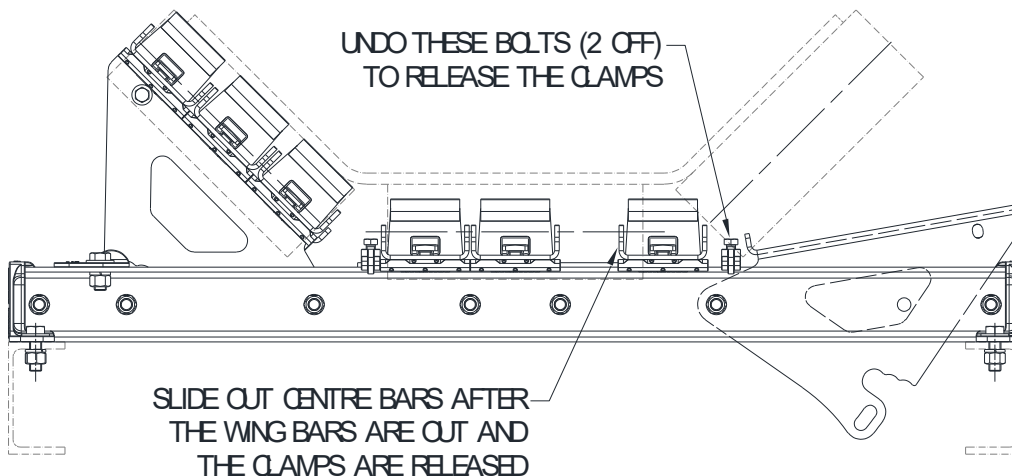

**Figure 5 - Sliding Out Centre Bars**

Step 8. Insert the cradle base onto the conveyor stringers in the appropriate position and align with stringers. Ensure that the base is centred and squared to the stringers and



clamped into position. As the proper insertion and removal of slide bars is entirely relying on the cradle base beams installed in parallel, double check the base beam locations by cross measuring their footprints. Some cradles are designed to accommodate packers in order to match the belt profile perfectly, in this case refer to the supplied installation arrangement for correct packer positioning.

- Step 9. Slide the centre bars onto the base frame and centre them on the base. Lock them in position by installing 4 slide clamps (2 per side)
- Step 10. If not already in position, install an impact idler set either side of the impact cradle base ensuring that 25mm clearance will be available at both ends of the centre impact bars (Figure 2).
- Step 11. Using a string line or straight edge ensure that the top of the centre bars is approximately 20mm below the top of the centre rollers of the impact idler frame (Fig 6). If this dimension is not approximately 20mm, packing of either the impact cradle base or the impact idler frames may be necessary to achieve this 20mm clearance. Please note accelerated bar wear will result from insufficient clearance. Belt damage may result from an excessive clearance due to lack of belt support. Once this clearance is achieved drill bolt holes in the stringers at appropriate position and bolt the cradle base in place. Alternatively, weld in place.

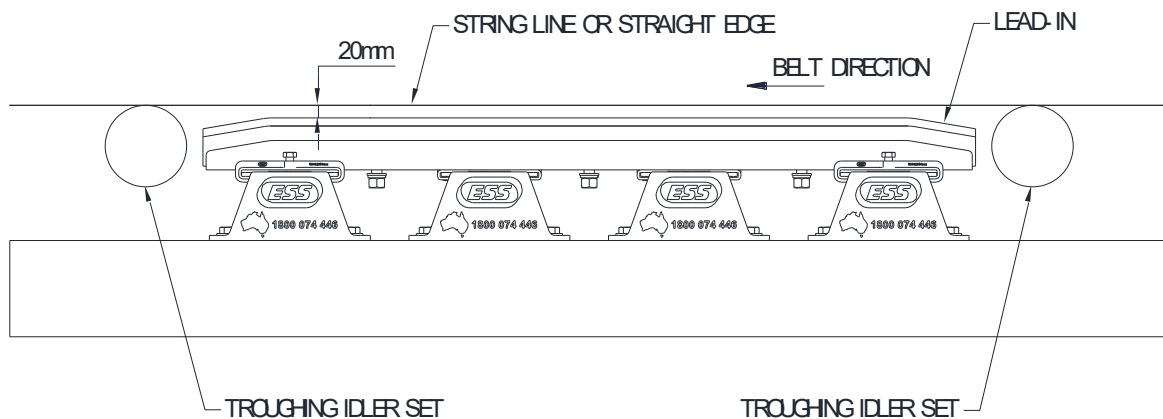

**Figure 6 - Cradle Positioning**

- Step 12. Re-assemble the cradle in reverse order of disassembly. The wing bars, that is the troughing bars, should also be approximately 20mm away from the troughing idler line (Figure 7).

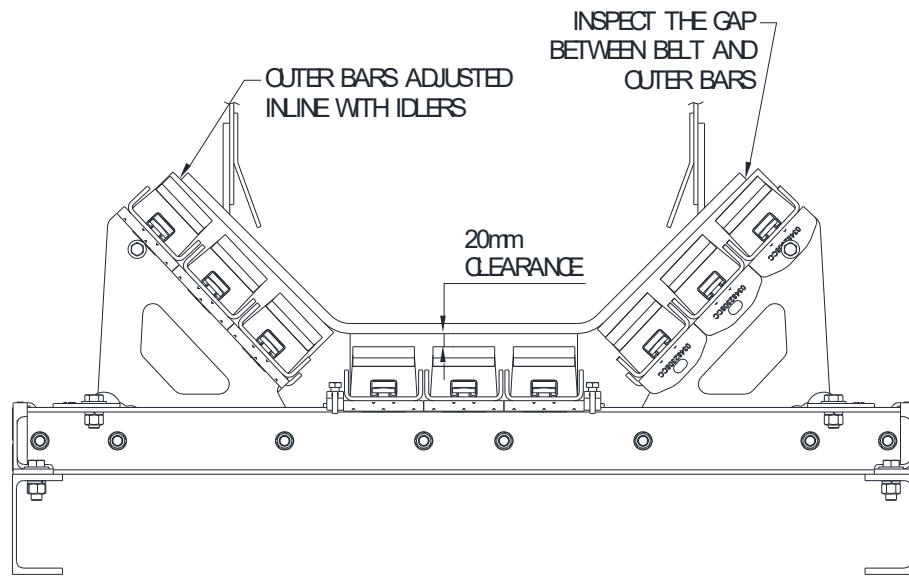

**Figure 7 - Cradle Setup Clearances**

Step 13. By adjusting the wing lock part in 3 different positions, the outer bar is brought up to be in line with the troughing idler rollers (Fig 8). Care should be taken to ensure that the outer bar is as close as possible to the roller line. If the bar is too high, accelerated wear will result. If the bar is too low, the belt may sag, resulting in material spillage.

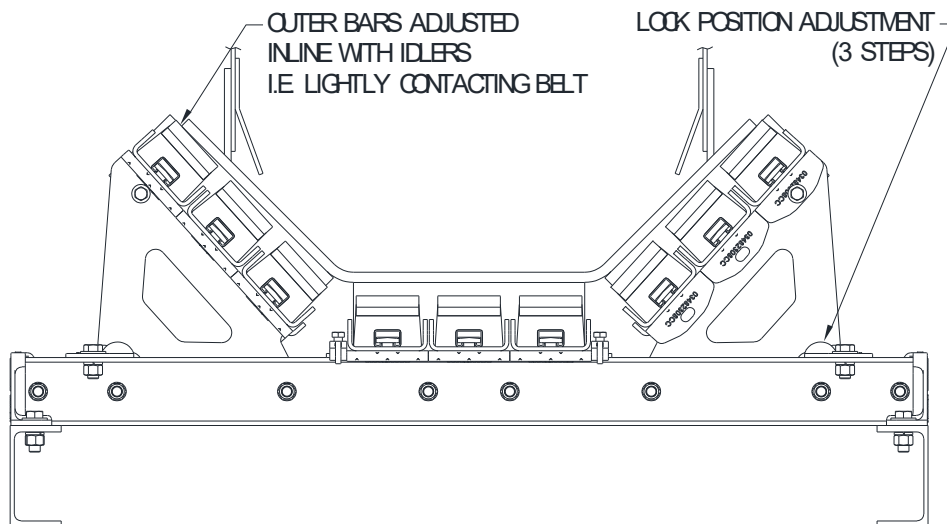

**Figure 8 - Wing Adjustment**

Step 14. Repeat the above procedure for all subsequent cradles.



**IF YOU HAVE ANY PROBLEMS, OR ARE UNCLEAR ON ANY INSTALLATION STEP, CONTACT  
ESS ON OUR CUSTOMER SERVICE NUMBER 1800 074446.**

Step 15. Remove danger tags and return conveyor to service, following plant procedures.



**CONVEYORS MUST BE SHUT DOWN AND LOCKED OUT BEFORE ANY INSTALLATION OR  
SERVICE WORK IS PERFORMED.**

## 4.2 COMMISSIONING

No special commissioning procedures are required for ESS Modular Impact Cradles.  
Provided the cradles are installed as per the drawing and instructions.



## 5.0 OPERATOR TRAINING

### 5.1 SERVICING

- Recommended dismantle, hose down, impact bar inspection and/or replacement and reassemble according to Section 6.3.
- There are no operator serviceable or adjustable functions on an ESS Modular Impact Cradle.
- No in-service procedures need to be followed, other than normal conveyor belt operating procedures.

### 5.2 SAFETY

As mentioned in Section 1, no additional safety hazards exist with an ESS Modular Impact Cradle, other than normal conveyor belt dangers.

Do not attempt to perform any job on or around a moving conveyor belt - isolate and tag the belt first.

### 5.3 PROBLEMS

The operator, during routine conveyor inspections, should be alert to the following problem indicators:

- Smoke or burning rubber smell - the belt should be stopped immediately, and the problem located. It is far more likely to be a seized impact idler or a skirting problem but could possibly indicate an impact cradle fault.
- Leakage of material from skirts at load zone - this should be notified to the appropriate maintenance personnel for attention at the earliest plant stoppage. It may mean that skirting requires attention, and/or that the impact cradle wings require adjustment.



## 6.0 ROUTINE MAINTENANCE AND SERVICE



**CONVEYORS MUST BE SHUT DOWN AND LOCKED OUT BEFORE ANY INSTALLATION OR SERVICE WORK IS PERFORMED.**

### 6.1 SAFETY

Before attempting any maintenance on or around a conveyor belt, ensure that the belt drive is isolated and tagged.

### 6.2 GENERAL

The ESS Modular Impact Cradle requires virtually no maintenance to operate under most normal conditions. However, to achieve the best bar life and avoid the need for unscheduled bar change-outs, the following maintenance practices should be adopted.

### 6.3 ROUTINE MAINTENANCE

The cradles should be disassembled (refer to Cradle Disassembly Procedure) and inspected for bar wear after one month of operation, and again after three months. Subsequent inspection frequency can be determined after the wear rate is assessed at these initial inspections. The UHMW-Polyethylene top cover of the bar is 12.5mm thick. The bars should be scheduled for change out when the top cover thickness reaches **2mm**.

**TIP** During inspection, higher wear areas may be identified on some bars, or sections of bars. This is caused by uneven belt loading in the transfer point. Longer overall bar life may be achieved by noting the position of the bars at disassembly and rotating the bars to a different position on re-assembly, much like rotating the tyres on a car.

### 6.4 CRADLE DISASSEMBLY PROCEDURE

The disassembly of an ESS Modular Impact Cradle is a simple process.

- Step 1. Start from one side by remove the outer wing bolt attaching wing part to the base (one per module side).
- Step 2. Remove the wing lock part supporting the wing (one per module side).
- Step 3. Flip down the wing set smoothly.
- Step 4. Remove the outer bar fasteners (2 off per side).



- Step 5. Slide the individual wing bar assemblies out. Note the bar positions by numbering (with a marking pen or chalk).
- Step 6. Repeat above for the other side.
- Step 7. Remove the slide clamps by undoing their securing bolts and then slide the centre bar assemblies of the base (again noting the positions).
- Step 8. Inspect the bars for wear or damage. If severe or unusual wear is noted, contact **ESS** on **1800 074446** for advice.

## 6.5 CRADLE RE-ASSEMBLY

Re-assemble the cradle in reverse order of disassembly, paying attention to the following:

- If new bars are being fitted, or if existing bar wear is negligible, refit the bars in any order.
- If wear spots are evident on certain bars, rearrange bars on re-assembly to maximise total bar life.



## 7.0 TROUBLESHOOTING

PROBLEM	CAUSE	SOLUTION
Smoke or burning rubber smell	Seized idler	Replace idler
	Over-adjusted or damaged skirting	Replace or adjust skirting rubber
	Worn out impact bar	Disassemble impact cradle and replace bars. If bar life is short or wear is uneven, contact <b>ESS</b>
Material spillage under skirts	Skirting rubber not adjusted or failed	Adjust or replace skirting
	Impact cradle wings not adjusted up to belt	Adjust the cradle wings



## 8.0 INSTALLATION ARRANGEMENT DRAWINGS

### 8.1.F0650 INSTALLATION LAYOUT

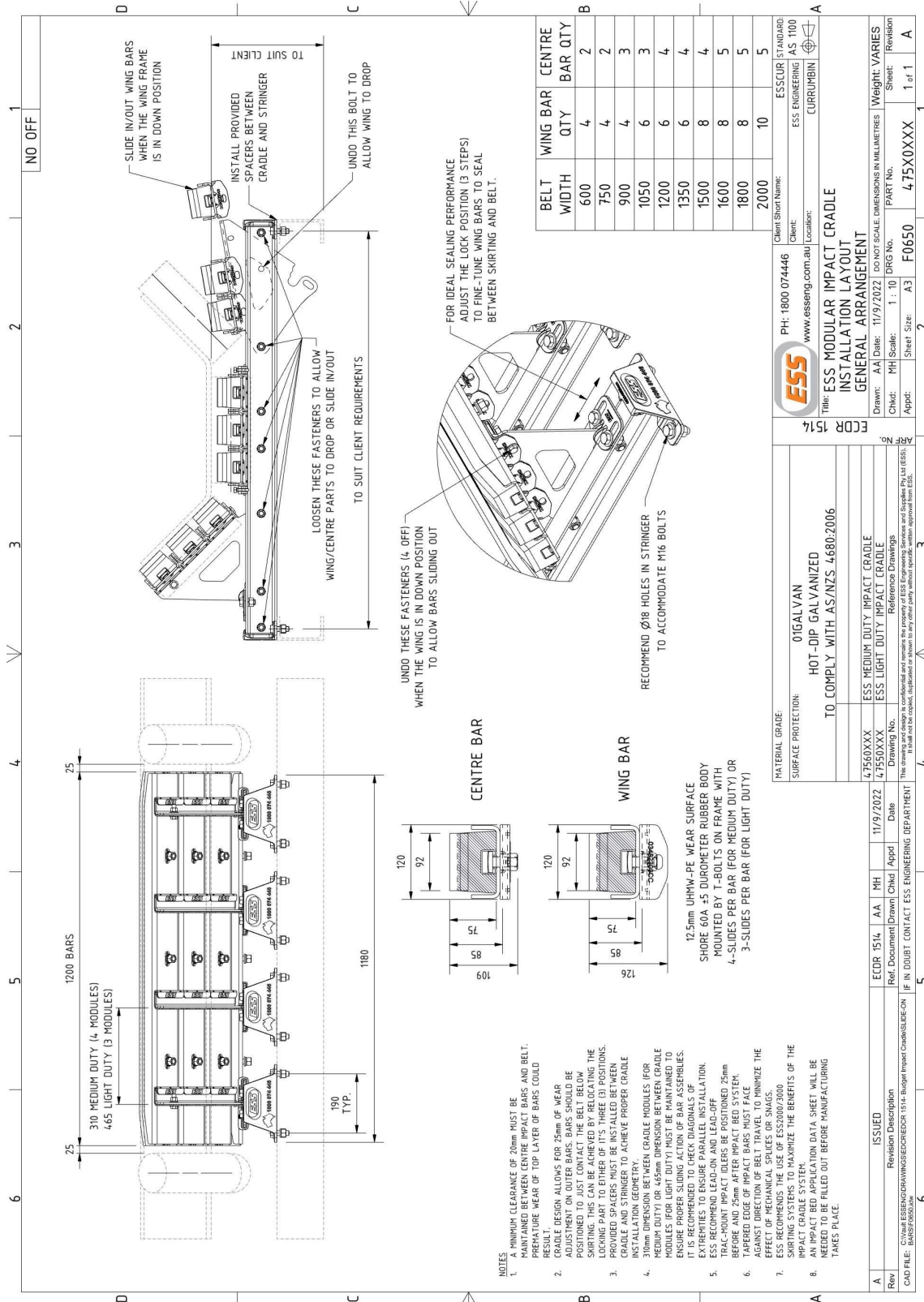



## 9.0 FINAL CHECKLIST

Site: \_\_\_\_\_ Number: \_\_\_\_\_ Date: \_\_\_\_\_

Site Equipment No./Location: \_\_\_\_\_ Site Contact: \_\_\_\_\_

Completed By: \_\_\_\_\_ (Circle Yes or No Below)

1. Was equipment to ESS Specification? \_\_\_\_\_ Yes/No

Drawing No. Ref: \_\_\_\_\_ Attached? Yes/No

If No, WHY \_\_\_\_\_

Will this affect performance? Yes/No

If Yes, WHY \_\_\_\_\_

2. Was this a standard  service  inspection  installation? Yes/No

If No, WHY \_\_\_\_\_

3. Was work carried out as per procedure and JSA? Yes/No

If No, WHY \_\_\_\_\_

4. Is equipment fit for commissioning? Yes/No

If No, WHY \_\_\_\_\_

5. Was a final inspection carried out while plant was running? Yes/No

If No, WHY \_\_\_\_\_

6. Has anything changed from previous service / inspection / installation? Yes/No

If Yes, WHAT \_\_\_\_\_

7. Is equipment performance to Client expectations? Yes/No

If No, WHY \_\_\_\_\_

ESS Signature: \_\_\_\_\_ Client Signature: \_\_\_\_\_

