

CE

POLIVALENTI
MULTIFUNCTION
POLIVALENT
MULTI-USAGES
POLIVALENTES



HOONVED

PEOPLE · PASSION · INNOVATION



CE 68 BT - CE 78 BT - CE 90 BT

Lavastoviglie / Lavaoggetti Polivalenti

Multifunction Dishwashers / Utensils washer
Multifunktions-Geschirrspüler, Polivalente Utensilienspülmaschine
Lavavaisselle et lave ustensiles multi-usages
Lavavajillas / Lavaobjetos Polivalentes

Ideale per / Suitable for / Ideal für
Idéals pour / Ideales para



Pasticceria

Confectioneries
Konditoreien
Pâtisseries
Pastelerías



Gelateria

Ice Cream Shops
Eisdielen
Glaciers
Heladerías



Ristoranti e Gastronomie

Restaurants & Gastronomies
Restaurants
Traiteurs et restaurants
Carnicerías



Fast Food

Fast Food
Fast Food
Restauration Rapide
Comida Rápida



Grande Distribuzione

Large Scale Retail Trade
Grosshandel
GMS
Gran Distribución



Panetteria

Bakeries
Bäckereien
Boulangeries
Panaderías

CE68 BT, CE78 BT e CE 90 BT sono lavaoggetti POLIVALENTI estremamente compatte, robuste e versatili. Perfette per rispondere alle esigenze dei laboratori di pasticceria, gastronomia e gelateria. Possono essere utilizzate anche come lavastoviglie ad elevata produttività.



CE68 BT, CE78 BT and CE 90 BT are highly VERSATILE and compact utensils washers. Perfect to satisfy the needs of pastry and ice-cream labs. They can be used also as high-productivity dishwashers.



CE68 BT, CE78 BT, CE90 BT sind extrem kompakte, robuste und vielseitige Untertisch-Utensilienspülmaschinen. Perfekt für um den besonderen Bedürfnissen von Backstuben, Konditoreien, Gastronomiebetrieben und Eisdielen. Sie können auch als Geschirrspüler mit hoher Produktivität genutzt werden.



CE68 BT, CE78 BT, CE90 BT sont des lave-ustensiles très résistantes et polyvalentes qui, grâce à leurs dimensions compactes, s'adaptent aux différentes exigences des secteurs de la restauration (notamment des laboratoires de pâtisserie, gastronomie et glaciers). Elles peuvent être utilisées aussi comme lave-vaisselle à haut débit.



CE68 BT, CE78 BT y CE90 BT son lavaobjetos polivalentes extremadamente compactas, robustas y versátiles. Perfecto para satisfacer las necesidades de las pastelerías, gastronomías y heladerías. También pueden utilizarse como lavavajillas altamente productivos.

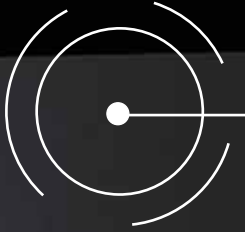

HOONVED





Ergonomia e robustezza



- Struttura in acciaio inox 18/10 satinato
- Boiler e resistenze in acciaio Incoloy inossidabile
- Pannellatura posteriore
- Microinterruttore di fermata ciclo in caso di apertura accidentale della porta
- Misurazione delle temperature tramite sonde elettroniche.



Strong and easy to use

- Finely brushed stainless steel 18/10 structure
- Incoloy stainless steel boiler and heaters
- Rear Panelling
- Magnetic door switch interrupts the cycle in case the door is opened accidentally
- Temperature measurement via electronic probes.



Ergonomie und Robustheit

- Struktur aus satiniertem Edelstahl 18/10
- Boiler und Heizelemente aus rostfreiem Incoloy-Edelstahl
- Rückwandverkleidung.
- Mikroschalter für die Zyklusunterbrechung bei versehentlichem Türöffnen
- Boiler- und Tanktemperaturregelung über NTC - Fühler



Ergonomie et robustesse

- Structure en acier inox 18/10 satiné
- Surchauffeur et résistances en acier Incoloy inoxydable
- Panneau arrière
- Micro-interrupteur d'arrêt du cycle en cas d'ouverture accidentelle de la porte
- Contrôle de températures par sondes.



Ergonomía y robustez

- Estructura de acero inoxidable 18/10 satinado
- Boiler y resistencias de acero Incoloy inoxidable
- Revestimiento trasero.
- Microinterruptor de parada de ciclo en caso de apertura accidental de la puerta
- Control de temperatura de caldera y tanque mediante sondas NTC.

Electronica intuitiva

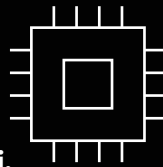

L'intuitivo pannello comandi permette di visualizzare sul display digitale i 4 cicli di lavaggio e risciacquo preimpostati, con tempi e temperature personalizzabili. Il pannello di controllo mostra i principali parametri di funzionamento, evidenziando eventuali anomalie.



Intuitive Electronics

The intuitive user design features clear cycle monitoring, colour-coded status indicators as well as four different programming options for washing cycles, with personalized times and temperatures. The control panel also shows all functioning parameters and highlights any anomalies.



Einfache, intuitive

Das intuitive Bedienfeld mit digitalem Display visualisiert die 4 vorprogrammierten Spül- und Nachspülzyklen, deren Dauer und Temperatur individuell einstellbar sind. Auf dem Bedienfeld werden die wichtigsten Betriebsparameter angezeigt und auf eventuelle Anomalien hingewiesen.



Électronique intuitive

Le panneau de commande intuitif permet de voir sur l'écran numérique les 4 cycles de lavage et de rinçage prédéfinis, dont les durées et les températures sont personnalisables.

Le panneau de commande montre les paramètres principaux de fonctionnement, et signale les anomalies.



Electrónica intuitiva

El intuitivo panel de comandos permite visualizar en la pantalla digital los 4 ciclos de lavado y aclarado preconfigurados con duraciones y temperaturas personalizables. El panel de control muestra los principales parámetros de funcionamiento, resaltando cualquier anomalía.

HOONVED





Versatilità

Progettate per igienizzare perfettamente utensili da cucina, vassoi da forno, padelle, ciotole per planetarie, contenitori, stoviglie, posate e bicchieri in modo molto rapido.

Utilizzabili come lavapiatti con una capacità di carico di 24 piatti fondi/26 piatti piani/12 piatti pizza Ø48 cm (+30% rispetto a una macchina tradizionale)



Versatility

Designed to perfectly sanitize kitchen utensils, baking trays and pans, planetary mixed bowls, and containers, crockery, cutlery, and glassware very quickly.

They can be used as dishwasher with a wash capacity of 24 deep plates/26 plates/12 pizza plates Ø48 cm (+30% compared to a traditional machine)



Vielseitigkeit

Entwickelt für perfekte Reinigung und Sanifizierung in kürzester Zeit von Küchenutensilien, Backblechen, Pfannen, Mixschüsseln planetarischer Rührgeräte sowie Behältern, Geschirr, Besteck und Gläser.

Nutzbar auch als Geschirrspüler mit großer Ladekapazität: 24 tiefe Teller, 26 flache Teller, 12 Pizzateller Ø48 cm (+ 30 % im Vergleich zu einer herkömmlichen Maschine)



Polyvalence

Notre gamme de lave-vaisselle compacts polyvalents est conçue soit pour désinfecter parfaitement et rapidement les ustensiles de cuisine, les plaques de cuisson, les casseroles et les bols mélangeurs planétaires, ainsi que la vaisselle, les couverts et la verrerie.

Elle est utilisable comme lave-vaisselle avec une capacité de charge de 24 assiettes creuses/26 assiettes, plates/12 assiettes à pizza de Ø48 cm de diamètre (+30 % par rapport à une machine traditionnelle)



Versatilidad

Nuestra gama de lavavajillas compactos multipropósito está diseñada para desinfectar perfectamente y de manera muy rápida utensilios de cocina, bandejas y sartenes para hornear, cuencos mezcladores planetarios, y recipientes, vajilla, cubertería y cristalería.

Pueden utilizarse como lavavajillas con una capacidad de carga de 24 platos hondos/26 platos llanos/12 platos de pizza Ø48 cm (+30% en comparación con una máquina convencional)



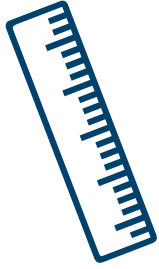

Grandi dimensioni di lavaggio

Grazie all'altezza utile di 400 mm (CE68 BT -CE78 BT) e 500 mm (CE90 BT) e al cestello 500x600mm: piatti, stoviglie, vassoi e contenitori di qualsiasi forma e dimensione possono essere lavati facilmente.



Big washing dimensions

Thanks to the 400 mm (CE68 BT - CE78 BT) and 500 mm (CE90 BT) clearances and the 500x600mm rack, plates, dishes, trays, and containers of any shape and size can be easily washed.



Großer Waschraum

Dank einer Nutzhöhe von 400 mm (CE68 BT - CE78 BT) und 500 mm (CE90 BT) und einem Waschkorb von 500x600mm, können Teller, Geschirr, Tablett und Bleche sowie Behälter jeder Form und Größe leicht gereinigt werden.



Dimensions de lavage importantes

Grâce à la hauteur utile de 400 mm (CE68 BT - CE78 BT) et 500 mm (CE90 BT) et au panier 500x600mm : les assiettes, les plats, les plateaux et les contenants de toutes formes et tailles peuvent être facilement lavés.



Grandes dimensiones de lavado

Gracias a la altura útil de 400 mm (CE68 BT - CE78 BT) y 500 mm (CE90 BT) y al cesto de 500x600 mm: platos, vajilla, bandejas y recipientes de cualquier forma y tamaño pueden lavarse fácilmente.





CE 68 BT TWIN LAVAGGIO BOTTIGLIE

Con il modello **CE68 / 78 TWIN** puoi lavare anche bottiglie e caraffe in vetro. Basta inserire il cestello bottiglie, 500x500mm in dotazione, e il gioco è fatto! **Semplice e immediato.**



CE 68 BT TWIN BOTTLE WASHING

With the **CE 68 / 78 TWIN** model you can wash glass bottles and jugs, just insert the supplied bottle basket 500x500mm and **you're done!**



CE 68 BT TWIN GLASFLÄSCHEN- SPÜLUNG

Mit dem Modell **CE 68 / 78 TWIN** kannst du auch Glasflaschen und -karaffen spülen. Einfach den mitgelieferten Flaschenkorb (500x500 mm) einsetzen, und schon ist alles erledigt! **Einfach und sofort nutzbar.**



CE 68 BT TWIN LAVAGE DES BOUTEILLES

Avec le modèle **CE 68 / 78 TWIN**, vous pouvez également laver des bouteilles et des carafes en verre. Il suffit d'insérer le panier pour bouteilles de 500x500 mm fourni, et le tour est joué ! **Simple et rapide.**



CE 68 BT TWIN LAVADO BOTELLAS

Con el modelo **CE 68 / 78 TWIN** también puedes lavar botellas y jarras de vidrio. Solo tienes que insertar la cesta para botellas de 500x500 mm incluida, ¡y listo! **Simple y rápido.**





DIAMETRO COLLO

Item Diameter / Flaschenhalsdurchmesser
Diamètre du col / Diámetro del cuello

min 16 mm

min 16 mm / mindestens 16 mm
min 16 mm / mín. 16 mm

ALTEZZA

Height / Höhe
Hauteur / Altura

max 320 mm

max 280 mm / maximal 280 mm
max 280 mm / máx 280 m

DIAMETRO FONDO

Bottom Diameter / Flaschenboden - Durchmesser
Diamètre du fond / Diámetro fondo

max 106 mm

max 106 mm / maximal 106 mm
max 106 mm / máx 106 mm



DIAMETRO

Item Diameter / Durchmesser
Diamètre / Diámetro

min 150 mm

min 150 mm / mindestens 150 mm / min 150
mm / mín. 150 mm





Igiene perfetta

- Sistema di filtraggio multiplo (filtro vasca e filtro di aspirazione della pompa)
- Ciclo di autolavaggio allo spegnimento della macchina
- Guide cestello arrotondate in filo
- Bracci rotanti superiori e inferiori di lavaggio e risciacquo in acciaio inossidabile facili da rimuovere.



Perfect hygiene

- Multiple filtration system (tank filter and pump suction filter)
- Self-cleaning cycle at unit switch-off
- Wire rounded rack guides
- Easy-to-remove stainless steel rotating upper and lower wash and rinse arms.



Perfekte Hygiene

- System mit Mehrfachfilter (Tankfilter und Pumpenansaugfilter)
- Selbstreinigungszyklus beim Ausschalten des Gerätes
- Korbführungen aus abgerundem Edelstahl Draht
- Edelstahl Spül- und Nachspülarms für einfache Reinigung.



Hygiène parfaite

- Système de filtration multiple (filtre de cuve et filtre d'aspiration de pompe)
- Cycle de nettoyage automatique à la fin du service
- Guides de panier en fil métallique
- Bras de lavage et de rinçage supérieur et inférieur en acier inoxydable faciles à enlever.



Higiene perfecta

- Sistema de filtración múltiple (filtro de tanque y filtro de la bomba)
- Ciclo de autolimpieza al apagar la unidad
- Guías de cesto redondeadas de alambre
- Brazos de lavado y vaclarado superior e inferior de acero inoxidable fáciles de quitar.



CE68 BT / CE78 BT



CE90 BT

OPTIONAL



H-Cloud by Hoonved Dashboard web / App per il controllo remoto

I vantaggi per te:

- **Prestazioni costanti e ottimizzazione dei consumi di acqua, energia e detersivo.**
- **Visualizzare e scaricare dati HACCP**
- **Riduzione fino al 50% del numero di trasferte per interventi tecnici!**
- **Possibilità per il tecnico di pianificare interventi di manutenzione preventiva**



Wi-Fi connection and Remote Control

The main advantages for you:

- **Constant performances and optimization of water, energy and detergent consumptions**
- **View and download HACCP data**
- **Money and time savings: up to 50% reduction in onsite technical interventions!**
- **Possibility for the technician to schedule predictive maintenance interventions.**



WLAN-Verbindung und Remote Control

Die Vorteile für Sie:

- **Auf Distanz kontrollierte, konstante Leistung und Optimieren des Wasser-, Energie- und Spütmittelverbrauchs.**
- **HACCP-Daten ansehen und herunterladen**
- **Bis zu 50% weniger Vor-Ort Besuche für technische Eingriffe notwendig!**
- **Möglichkeit für den Techniker, vorbeugende Wartungseingriffe zu planen.**



Connexion Wi-Fi

Les avantages pour vous :

- **Performances constantes et optimisation des consommations d'eau, d'énergie et de détergent.**
- **Afficher et télécharger les données HACCP**
- **Réduction jusqu'à 50% du nombre de déplacement pour des interventions techniques !**
- **Possibilité pour le technicien de planifier des interventions de maintenance préventive.**



Conexión Wi-Fi y Control Remoto

Las ventajas para ti:

- **Rendimiento constante y consumo optimizado de agua, energía y detergente.**
- **Visualizar y descargar los datos HACCP**
- **¡Reducción de hasta un 50% del número de desplazamientos para intervenciones técnicas!**
- **Possibilidad de que el técnico planifique las intervenciones de mantenimiento preventivo.**



Caratteristiche tecniche

Technical features / Technische Eigenschaften

Caractéristiques techniques / Características técnicas

Modelli	
Models Modelle Modèles Modelos	
Durata ciclo	Cycle length / Zyklusdauer Durée du cycle / Duración del ciclo
Produttività max teorica* (cestelli/h)	Max theoretical output capacity / Theoretische Maximalleistung Productivité max. théorique / Productividad máxima teórica* (racks/h - Körbe/Stunde - paniers/h - cestas/h)
Altezza utile porta	Clearance / Nutzhöhe Hauteur Utile / Altura Útil
Cesto	Rack / Korb / Panier / Cesta
Costruzione	Construction/ Konstruktion Construction/ Construcción
Interno macchina	Machine interior / Maschineninnenraum Intérieur machine / Interior máquina
Pompa lavaggio	Washing pump / Spülpumpe Pompe de lavage / Bomba de lavado
Dosatore brillantante	Rinse aid-pump / Klarspülmitteldosierer Doseur liquide de rinçage / Dosificador de abrillantador
Dosatore detersivo	Detergent doser / Reinigerdosierer Doseur détergent / Dosificador de detergente
Sistema Break Tank	Break Tank System / Break Tank System Système Break Tank / Sistema Break Tank
Allacciamento elettrico	Electrical connection / Elektrischer Anschluss Connexion électrique / Conexión eléctrica
Potenza totale	Total power / Gesamt-Anschlusswert Puissance totale / Potencia total
Resistenza boiler	Boiler heater / Boilerheizung Résistance Surchauffeur / Resistencia boiler
Resistenza vasca	Tank heater / Tankheizung Résistance cuve / Resistencia cuba
Capacità vasca	Tank capacity / Tankkapazität Capacité cuve / Capacidad cuba
Capacità boiler	Boiler capacity / Boilerkapazität Capacité Surchauffeur / Capacidad boiler
Alimentazione idrica	Water supply / Wasserversorgung Alimentation en eau / Alimentación hídrica
Consumo acqua ciclo	Water consumption per cycle / Wasserverbrauch pro Spülzyklus Consommation d'eau par cycle / Consumo agua/ciclo
Raccordo scarico	Drain hose connection / Abflussanschluss Raccord de vidange / Conexión desagüe
Livello pressione acustica	Acoustic pressure level / Schalldruckpegel Niveau de pression acoustique / Nivel presión acústica

***I valori riportati sono da considerarsi indicativi e possono variare in funzione delle condizioni di installazione, di lavoro, accessori e delle caratteristiche degli oggetti da lavare.**

*The stated values are to be considered as indicative and may vary depending on installation and working conditions, accessories, and the characteristics of the items to be washed.

*Die angegebenen Werte sind Richtwerte und können je nach Installations- und Arbeitsbedingungen, Zubehör und Eigenschaften des Spülguts variieren.

*Les valeurs indiquées sont données à titre indicatif et peuvent varier en fonction des conditions d'installation et de fonctionnement, des accessoires et des caractéristiques des objets à laver.

*Los valores indicados son orientativos y pueden variar según las condiciones de instalación y trabajo, los accesorios y las características de los objetos a lavar.

Macchina con voltaggi speciali a richiesta.

Machine with special voltages upon request.

Maschine mit Sonder-Spannungen auf Anfrage.

Machine avec tensions spéciales sur demande.

Máquina con tensiones especiales bajo pedido.



CE 68 BT / CE68 TWIN*	CE 78 BT	CE 90 BT
120/180/240/480 sec	120/180/240/480 sec	120/240/360/600 sec
30	30	30
400 mm	400 mm	500 mm
500x600 mm / 500x500*	500x600 mm	500x600 mm
Singola parete / Single wall / Einwandig / Simple paroi / Pared simple	Singola parete / Single wall / Einwandig / Simple paroi / Pared simple	Singola parete / Single wall / Einwandig / Simple paroi / Pared simple
Autopulente / Self-cleaning / Selbstreinigend / Auto-nettoyant / Autolimpiante	Autopulente / Self-cleaning / Selbstreinigend / Auto-nettoyant / Autolimpiante	Autopulente / Self-cleaning / Selbstreinigend / Auto-nettoyant / Autolimpiante
830 W	830 W	1620 W
Standard	Standard	Standard
Standard	Standard	Standard
Standard	Standard	Standard
Multipower - 400V 3N~ 50 Hz / 230V 3N~ 50 Hz / 230V ~ 50 Hz	Multipower - 400V 3N~ 50 Hz / 230V 3N~ 50 Hz / 230V ~ 50 Hz	230V 3~ 50 Hz / 400V 3N ~ 50 Hz
7830 W	7830 W	10620 W
7000 W	7000 W	9000 W
2000 W	2000 W	3000 W
23 l	23 l	42 l
7,5 l	7,5 l	10,5 l
2÷4 bar ø 3/4" G	2÷4 bar ø 3/4" G	2÷4 bar ø 3/4" G
3,5 l	3,5 l	4 l
ø 31 mm	ø 31 mm	ø 31 mm
< 70db (A)	< 70db (A)	< 70db (A)

Dati tecnici e foto sono indicativi con riserva di apportare eventuali modifiche senza preavviso.

The manufacturer reserves to alter the technical details and photos without warning.

Die technischen Daten und Fotos sind Richtwerte und können ohne vorherige Ankündigung geändert werden.

Les données techniques et photos sont indicatives, sous réserve d'apporter des modifications sans préavis.

Los datos técnicos y fotos son indicativos y pueden modificarse sin previo aviso.



Prodotto secondo le normative europee

Produced according to European standards
Produkt nach europäischen Normen gefertigt
Produit selon la réglementation européenne
Fabricado según las normas europeas

CE 68 BT

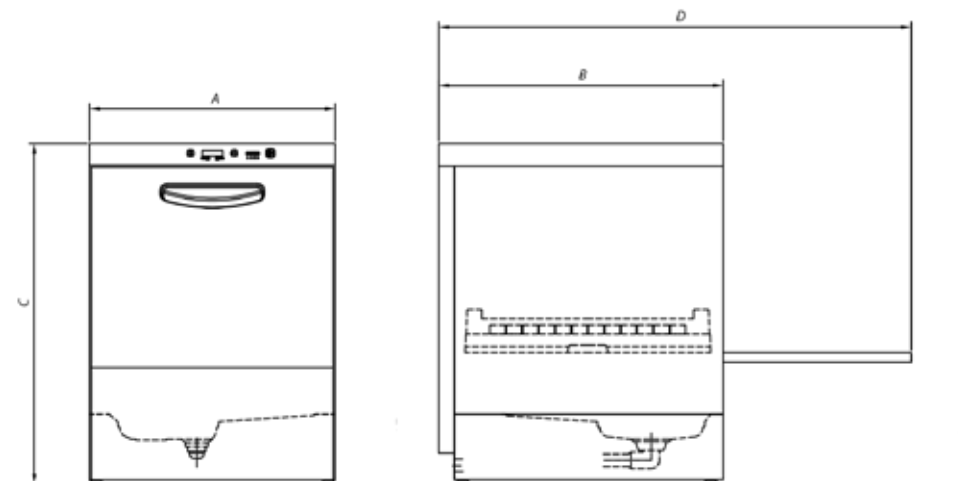

	A (mm)	B (mm)	C (mm)	D (mm)
CE 68 BT	600	695	830	1150

CE 68 TWIN

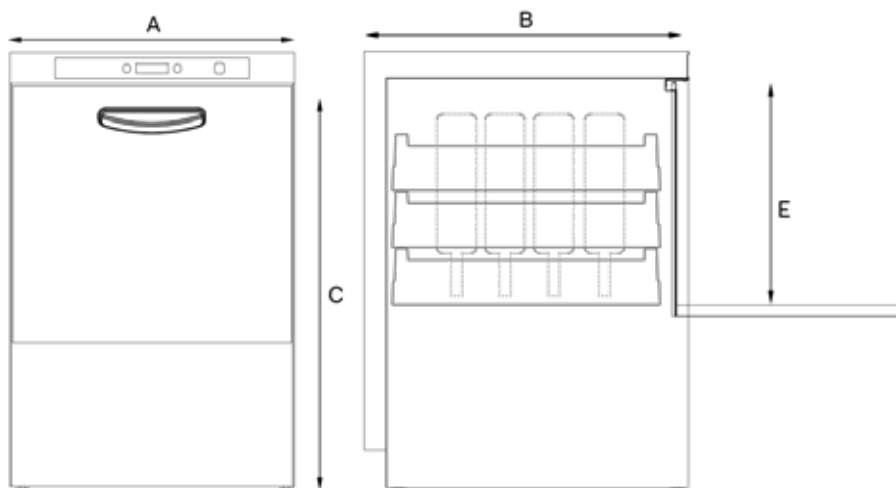

	A (mm)	B (mm)	C (mm)	E (mm)
CE 68 TWIN	600	695	830	400

Dati tecnici e foto sono indicativi con riserva di apportare eventuali modifiche senza preavviso.

The manufacturer reserves to alter the technical details and photos without warning.

Die technischen Daten und Fotos sind Richtwerte und können ohne vorherige Ankündigung geändert werden.

Les données techniques et photos sont indicatives, sous réserve d'apporter des modifications sans préavis.

Los datos técnicos y fotos son indicativos y pueden modificarse sin previo aviso.

CE 78 BT

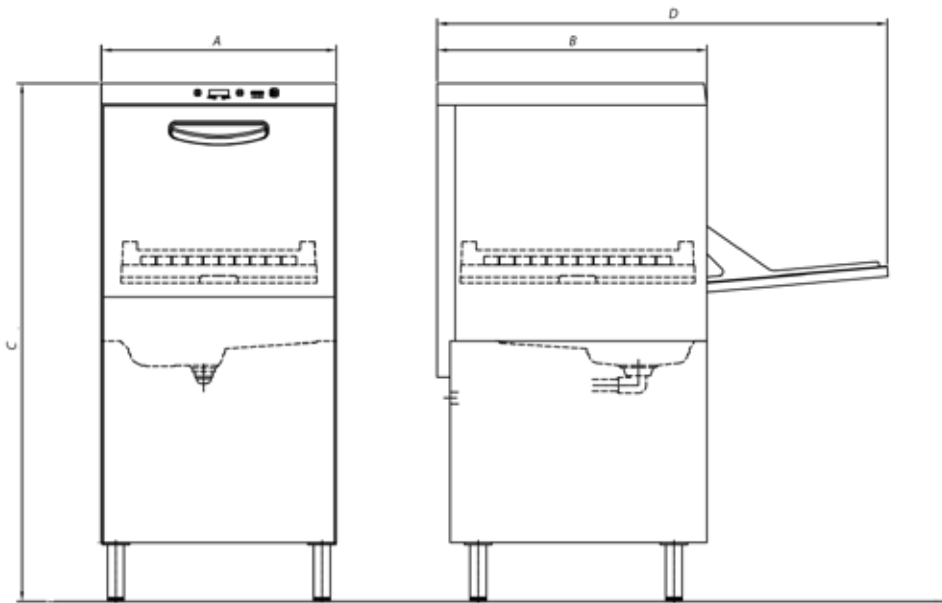

	A (mm)	B (mm)	C (mm)	D (mm)
CE 78 BT	600	695	1325	1150

CE 90 BT

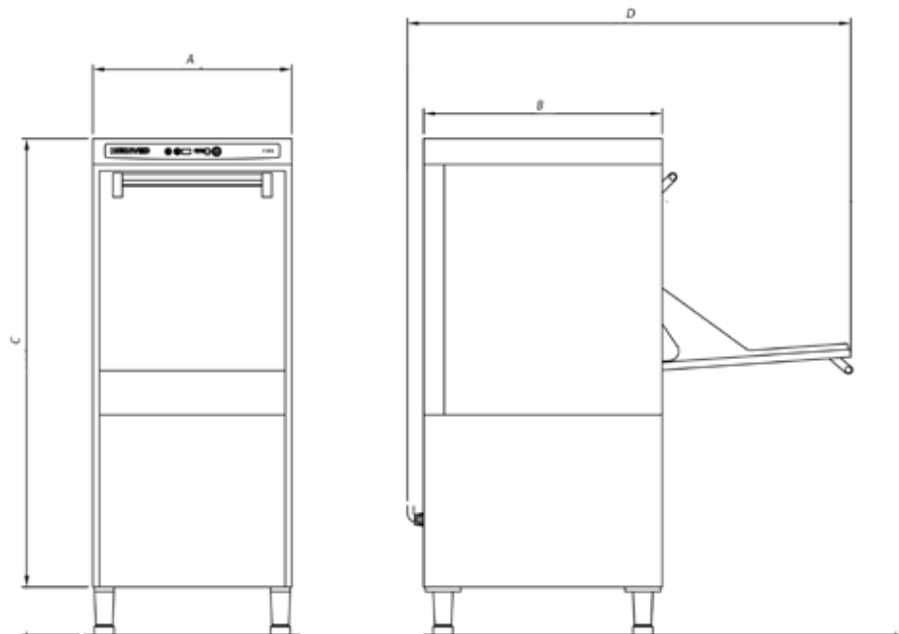

	A (mm)	B (mm)	C (mm)	D (mm)
CE 90 BT	620	742	1530	1375

Cestelli / inserti

Racks / inserts - Korb / Einsätze - Paniers / inserts - Cestas / insertos

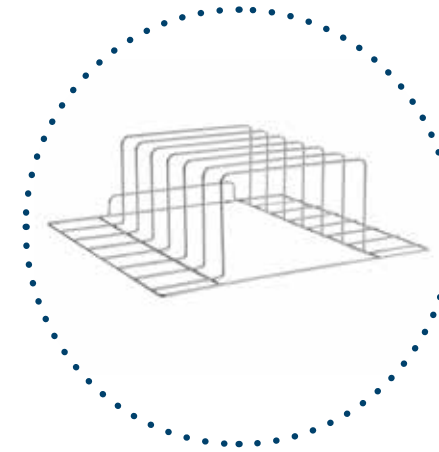
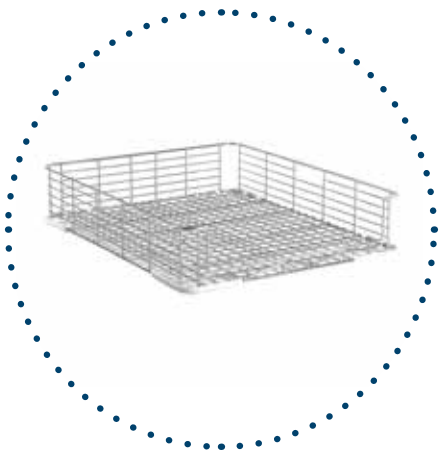

Dati tecnici e foto sono indicativi con riserva di apportare eventuali modifiche senza preavviso.

The manufacturer reserves to alter the technical details and photos without warning.

Die technischen Daten und Fotos sind Richtwerte und können ohne vorherige Ankündigung geändert werden.

Les données techniques et photos sont indicatives, sous réserve d'apporter des modifications sans préavis.

Los datos técnicos y fotos son indicativos y pueden modificarse sin previo aviso.

HOONVED

PEOPLE · PASSION · INNOVATION

HOONVED Ali Group S.r.l a Socio Unico

Via Ugo Foscolo, 1 - 21040 Venegono Superiore (VA) - Italy
T +39 0331 856111 · Fax +39 0331 865223 · P. IVA 13239980967

www.hoonved.com



an Ali Group Company



The Spirit of Excellence

H39469/0625