

MARCATURA CE	4 - 5
LAMINATI	6 - 19
TRAVI	20 - 29
TAGLIO E FORATURA	30 - 37
TUBOLARI	38 - 57
PROFILATI A FREDDO	58 - 63
LAMIERE	64 - 67
ACCIAIO INOX	68 - 81
RETI E GRIGLIATI E GRADINI	82 - 91
LAMIERE GRECATE	92 - 94
POLICARBONATO E PANNELLI COIBENTATI	95 - 101

POLETTI SpA

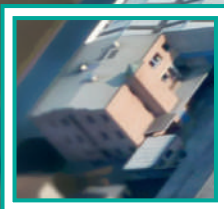

Cortesia

Flessibilita'

Velocita'



*Vasta gamma di prodotti
e servizi*



EN - 1090 - EXC4



IIS CERT

UNI EN 1090-1

Con l'entrata in vigore della normativa comunitaria EN-1090 (marcatura CE per i componenti strutturali in acciaio), per i produttori e rivenditori si rende necessario normare il proprio processo produttivo, rendendolo conforme alle indicazioni contenute nella norma.

Poletti SpA ha recepito a pieno titolo le indicazioni contenute nella normativa UNI EN 1090-1 (Esecuzione di strutture in acciaio e alluminio): il processo di produzione in fabbrica (FPC) risulta a pieno titolo certificato secondo le disposizioni della normativa UNI EN 1090-1.

Il numero univoco del certificato rilasciato a Poletti SpA è il seguente:

0475-CPR-105



POLETTI SpA



marcatura CE per i componenti strutturali in acciaio

Poletti SpA è ad oggi certificata e autorizzata a rilasciare le Dichiarazioni di Prestazione riferite al materiale sottoposto a processi di lavorazione e legate ai parametri soggetti alla normativa:

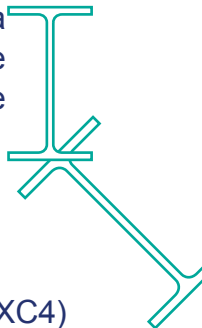

Qualità del materiale (S235, S275, S355)

Resistenza alla rottura (JR, J0, J2)

Classe di Esecuzione (EXC1, EXC2, EXC3, EXC4)

Sarà premura di Poletti SpA fornire la documentazione necessaria per ogni ordine, pregandoVi cortesemente di specificare al nostro Ufficio Vendite o ai nostri Agenti i parametri necessari. L'Ufficio e gli Agenti sono sempre a disposizione in caso di richieste particolari o chiarimenti.

In caso non venga specificata alcuna informazione, in fase d'ordine, verrà attribuita automaticamente la Classe di Esecuzione 2.

PIATTI LAMINATI E TRAFILATI

Larghezza [mm]	Spessore [mm]							
	3	4	5	6	7	8	10	12
	Peso [kg/m]							
10	0,24	0,31	0,39	0,47	0,55	0,63	-	-
12	0,28	0,38	0,47	0,57	0,66	0,75	0,94	-
15	0,35	0,47	0,59	0,71	0,83	0,94	1,18	1,41
16	0,38	0,50	0,63	0,75	0,88	1,01	1,26	1,51
20	0,47	0,63	0,79	0,94	1,10	1,26	1,57	1,89
25	0,59	0,79	0,98	1,18	1,38	1,57	1,97	2,36
30	0,71	0,94	1,18	1,41	1,65	1,89	2,36	2,83
35	0,83	1,10	1,38	1,65	1,93	2,20	2,75	3,30
40	0,94	1,26	1,57	1,89	2,20	2,52	3,14	3,77
45	1,06	1,41	1,77	2,12	2,48	2,83	3,54	4,24
50	1,18	1,57	1,97	2,36	2,75	3,14	3,93	4,72
55	1,30	1,73	2,16	2,59	3,03	3,46	4,32	5,19
60	1,41	1,89	2,36	2,83	3,30	3,77	4,72	5,66
65	1,53	2,04	2,55	3,07	3,58	4,09	5,11	6,13
70	1,65	2,20	2,75	3,30	3,85	4,40	5,50	6,60
80	1,89	2,52	3,14	3,77	4,40	5,03	6,29	7,55
90	2,12	2,83	3,54	4,24	4,95	5,66	7,07	8,49
100	2,36	3,14	3,93	4,72	5,50	6,29	7,86	9,43
110	2,59	3,46	4,32	5,19	6,05	6,92	8,65	10,38
120	2,83	3,77	4,72	5,66	6,60	7,55	9,43	11,32
130	3,07	4,09	5,11	6,13	7,15	8,17	10,22	12,26
140	3,30	4,40	5,50	6,60	7,70	8,80	11,00	13,20
150	3,54	4,72	5,90	7,07	8,25	9,43	11,79	14,15

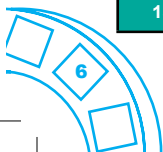



Larghezza [mm]	Spessore [mm]							
	15	20	25	30	35	40	50	60
	Peso [kg/m]							
10	-	-	-	-	-	-	-	-
12	-	-	-	-	-	-	-	-
15	-	-	-	-	-	-	-	-
16	-	-	-	-	-	-	-	-
20	2,36	-	-	-	-	-	-	-
25	2,95	3,93	-	-	-	-	-	-
30	3,54	4,72	5,90	-	-	-	-	-
35	4,13	5,50	6,88	8,25	-	-	-	-
40	4,72	6,29	7,86	9,43	11,00	-	-	-
45	5,31	7,07	8,84	10,61	12,38	14,15	-	-
50	5,90	7,86	9,83	11,79	13,76	15,72	-	-
55	6,48	8,65	10,81	12,97	15,13	17,29	-	-
60	7,07	9,43	11,79	14,15	16,51	18,86	23,58	-
65	7,66	10,22	12,77	15,33	17,88	20,44	25,55	-
70	8,25	11,00	13,76	16,51	19,26	22,01	27,51	33,01
80	9,43	12,58	15,72	18,86	22,01	25,15	31,44	37,73
90	10,61	14,15	17,69	21,22	24,76	28,30	35,37	42,44
100	11,79	15,72	19,65	23,58	27,51	31,44	39,30	47,16
110	12,97	17,29	21,62	25,94	30,26	34,58	43,23	51,88
120	14,15	18,86	23,58	28,30	33,01	37,73	47,16	56,59
130	15,33	20,44	25,55	30,65	35,76	40,87	51,09	61,31
140	16,51	22,01	27,51	33,01	38,51	44,02	55,02	66,02
150	17,69	23,58	29,48	35,37	41,27	47,16	58,95	70,74



LARGHI PIATTI

Larghezza [mm]	Spessore [mm]											
	6	8	10	12	15	20	25	30	35	40	50	60
	Peso [kg/m]											
160	7,55	10,06	12,58	15,09	18,86	25,15	31,44	37,73	44,02	50,30	62,88	75,46
180	8,49	11,32	14,15	16,98	21,22	28,30	35,37	42,44	49,52	56,59	70,74	84,89
200	9,43	12,58	15,72	18,86	23,58	31,44	39,30	47,16	55,02	62,88	78,60	94,32
220	10,38	13,83	17,29	20,75	25,94	34,58	43,23	51,88	60,52	69,17	86,46	103,75
250	11,79	15,72	19,65	23,58	29,48	39,30	49,13	58,95	68,78	78,60	98,25	117,90
280	-	-	22,01	26,41	33,01	44,02	55,02	66,02	77,03	88,03	110,04	132,05
300	-	-	23,58	28,30	35,37	47,16	58,95	70,74	82,53	94,32	117,90	141,48
320	-	-	25,15	30,18	37,73	50,30	62,88	75,46	88,03	100,61	-	-
350	-	-	27,47	33,01	41,27	55,02	68,78	82,53	-	-	-	-
380	-	-	-	-	44,80	59,74	74,67	89,60	-	-	-	-
400	-	-	31,40	37,68	47,16	62,88	78,60	94,32	-	-	-	-

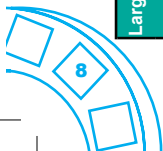

TONDI E QUADRI

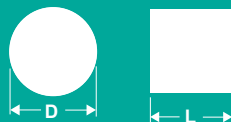

Diametro o lato [mm]	Tondi	Quadri
	Peso [kg/m]	
5	0,15	0,20
6	0,22	0,28
7	0,30	0,39
8	0,40	0,50
9	0,50	0,64
10	0,62	0,79
11	0,75	0,95
12	0,89	1,13
13	1,04	1,33
14	1,21	1,54
15	1,39	1,77
16	1,58	2,01
17	1,78	2,27
18	2,00	2,55
19	2,23	2,84
20	2,47	3,14
21	2,72	3,47
22	2,99	3,80
23	3,27	4,16
24	3,56	4,53
25	3,86	4,91
26	4,17	5,31
27	4,50	5,73
28	4,84	6,16
29	5,19	6,61

Diametro o lato [mm]	Tondi	Quadri
	Peso [kg/m]	
30	5,56	7,07
32	6,32	8,05
33	6,72	-
34	7,14	9,09
35	7,56	9,63
36	8,00	10,19
37	8,45	-
38	8,91	11,35
39	9,39	-
40	9,88	12,58
42	10,89	13,87
43	11,41	-
45	12,50	15,92
46	13,06	16,63
47	13,64	-
48	14,22	18,11
50	15,43	19,65
52	16,69	21,25
53	17,34	22,08
55	18,67	23,78
56	19,36	24,65
58	20,77	26,44
60	22,22	28,30
63	24,50	31,20
65	26,08	33,21

Diametro o lato [mm]	Tondi	Quadri
	Peso [kg/m]	
68	28,55	36,34
70	30,25	38,51
73	32,90	41,89
75	34,72	44,21
78	37,56	47,82
80	39,51	50,30
83	42,53	-
85	44,60	56,79
88	47,81	-
90	50,00	63,67
93	53,39	-
95	55,71	70,94
100	61,73	78,60
105	68,06	86,66
110	74,70	95,11
115	81,64	103,95
120	88,89	113,18
125	96,46	122,81
130	104,33	132,83
140	121,00	154,06
150	138,90	176,85
160	158,03	201,22
170	178,41	227,15
180	200,01	254,66
200	246,93	314,40

FERRI ANGOLARI

Dimensioni [mm]	Spessore [mm]							
	3	4	5	6	7	8	9	10
	Peso [kg/m]							
15x15	0,65	0,83	-	-	-	-	-	-
20x20	0,88	1,14	-	-	-	-	-	-
25x25	1,12	1,45	1,79	-	-	-	-	-
30x30	1,40	1,78	2,17	2,57	-	-	-	-
35x35	1,63	2,10	2,61	3,04	-	-	-	-
40x40	1,88	2,42	3,00	3,52	4,04	4,55	-	-
45x45	-	2,80	3,38	3,99	4,60	5,18	-	-
50x50	-	3,13	3,77	4,46	5,15	5,81	-	-
55x55	-	-	4,18	4,95	5,71	6,46	-	-
60x60	-	-	4,56	5,42	6,26	7,09	7,90	8,69
65x65	-	-	5,00	5,95	6,83	7,73	-	9,48
70x70	-	-	5,37	6,38	7,38	8,36	9,34	10,34
75x75	-	-	-	7,00	8,00	9,03	10,00	11,07
80x80	-	-	-	7,34	-	9,66	10,75	11,85
90x90	-	-	-	-	-	10,90	12,17	13,42
100x100	-	-	-	9,20	-	12,30	13,70	15,10
110x110	-	-	-	-	-	-	-	16,60
120x120	-	-	-	-	-	14,70	16,40	18,30
130x130	-	-	-	-	-	-	-	-
140x140	-	-	-	-	-	-	-	-
150x150	-	-	-	-	-	-	-	-
160x160	-	-	-	-	-	-	-	-
180x180	-	-	-	-	-	-	-	-
200x200	-	-	-	-	-	-	-	-

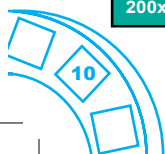



Dimensioni [mm]	Spessore [mm]							
	11	12	13	14	15	16	18	20
	Peso [kg/m]							
15x15	-	-	-	-	-	-	-	-
20x20	-	-	-	-	-	-	-	-
25x25	-	-	-	-	-	-	-	-
30x30	-	-	-	-	-	-	-	-
35x35	-	-	-	-	-	-	-	-
40x40	-	-	-	-	-	-	-	-
45x45	-	-	-	-	-	-	-	-
50x50	-	-	-	-	-	-	-	-
55x55	-	-	-	-	-	-	-	-
60x60	-	-	-	-	-	-	-	-
65x65	-	-	-	-	-	-	-	-
70x70	-	-	-	-	-	-	-	-
75x75	-	-	-	-	-	-	-	-
80x80	12,95	14,05	15,45	16,90	-	-	-	-
90x90	14,68	15,89	17,11	18,31	19,52	20,70	-	-
100x100	16,45	17,80	19,20	20,60	21,95	23,30	-	-
110x110	18,15	19,70	21,20	22,80	24,30	25,80	-	-
120x120	19,90	21,72	23,30	25,10	26,60	28,45	-	-
130x130	21,80	23,60	25,50	27,20	29,10	30,90	34,45	-
140x140	-	25,40	27,50	29,45	31,40	33,35	37,22	-
150x150	-	27,00	29,38	31,60	33,75	35,90	40,10	-
160x160	-	-	-	33,85	36,10	38,35	42,85	-
180x180	-	-	-	38,40	41,00	43,65	48,53	53,70
200x200	-	-	-	42,90	45,60	48,67	54,45	59,90

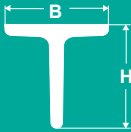

FERRI A 'T'

SPIGOLI TONDI

Lati [mm]		Spessore [mm]	Peso [kg/m]
B	H		
45	45	5,5	3,37
50	50	6	4,44
60	60	7	6,28
70	70	8	8,32
80	80	9	10,70
90	90	10	13,40
100	100	11	16,40



FERRI A 'T'

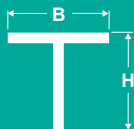

SPIGOLI VIVI

Lati [mm]		Spessore [mm]	Peso [kg/m]
B	H		
20	20	4	1,13
25	25	4,5	1,61
30	30	4	1,77
30	30	5	2,16
35	35	5,5	2,79
40	40	6	3,49
45	45	5,5	4,27
50	50	6	4,44
50	50	7	5,12
60	60	7	6,22
60	60	8	7,04
70	70	9	9,27
80	80	10	11,79
90	90	10	13,36
100	100	11	16,34

FERRI A 'L'

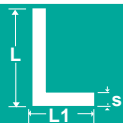

SPIGOLI VIVI

Dimensioni LxL ₁ xS [mm]	Peso [kg/m]	Dimensioni LxL ₁ xS [mm]	Peso [kg/m]	Dimensioni LxL ₁ xS [mm]	Peso [kg/m]
20x12x4	0,88	35x20x5,5	2,14	50x30x6	3,49
25x15x4,5	1,25	40x22x6	2,64	50x30x7	4,01
30x17,5x5	1,67	45x30x6,5	3,50		

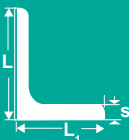

FERRI A 'L'

SPIGOLI TONDI

Dimensioni	Peso	Dimensioni	Peso	Dimensioni	Peso
LxL,xS	[kg/m]	LxL,xS	[kg/m]	LxL,xS	[kg/m]
[mm]		[mm]		[mm]	
25x15x3	0,96	70x50x6	5,44	110x65x8	11,20
30x20x4	1,45	70x50x7	6,28	110x75x10	13,80
30x20x5	1,77	70x50x8	7,10	120x60x8	10,90
35x20x4	1,61	70x50x10	8,71	120x60x10	13,40
35x20x5	1,97	75x50x6	5,65	120x80x8	12,20
40x20x4	1,77	75x50x7	6,53	120x80x10	15,00
40x20x5	2,17	80x40x6	5,41	120x80x12	17,80
40x25x4	1,92	80x40x8	7,07	130x65x8	11,90
40x25x5	2,36	80x60x7	7,35	130x65x10	14,60
45x30x4	2,25	80x60x8	8,33	130x65x12	17,30
45x30x5	2,77	80x60x10	10,20	150x100x10	19,30
45x30x6	3,27	80x60x12	12,20	150x100x12	22,60
50x30x5	2,96	100x50x6	6,85	150x100x14	26,10
50x30x6	3,51	100x50x8	8,99	200x90x12	26,30
60x30x5	3,37	100x50x10	11,10	200x90x15	32,50
60x30x6	3,95	100x65x7	8,77	200x100x10	23,00
60x30x7	4,59	100x65x8	9,95	200x100x12	27,30
60x40x5	3,76	100x65x9	11,10	200x100x14	31,64
60x40x6	4,46	100x65x10	12,30	200x100x16	35,90
60x40x7	5,14	100x65x11	13,40	200x100x18	40,00

POLETTI SpA



TABELLE DI COMPARAZIONE

COMPOSIZIONE CHIMICA DI COLATA

Qualità	Composizione chimica di colata						
	C % max	Mn % max	Si % max	P % max	S % max	N % max	Cu % max
S 235 JR	0,170	1,400	-	0,045	0,045	0,009	-
S 235 J0	0,170	1,400	-	0,040	0,040	0,009	-
S235 J2G4	0,170	1,400	-	0,035	0,035	-	-
S 235 J2 G4 (Cu)	0,170	1,400	-	0,035	0,035	-	0,25-0,40
S 275 JR	0,210	1,500	-	0,045	0,045	0,009	-
S 275 J0	0,180	1,500	-	0,040	0,040	0,009	-
S 275 J2 G3	0,180	1,500	-	0,035	0,035	-	-
S 275 J2 G4	0,180	1,500	-	0,035	0,035	-	-
S 275 J2 G4 (Cu)	0,180	1,500	-	0,035	0,035	-	0,25-0,40
S 355 JR	0,240	1,600	0,550	0,045	0,045	-	-
S 355 J0	0,200	1,600	0,550	0,040	0,040	0,009	-
S 355 J2 G3	0,200	1,600	0,550	0,035	0,035	-	-
S 355 J2 G4	0,200	1,600	0,550	0,035	0,035	-	-
S 355 J2 G4 (Cu)	0,200	1,600	0,550	0,035	0,035	-	0,25-0,40
S 355 K2 G3	0,200	1,600	0,550	0,035	0,035	-	-

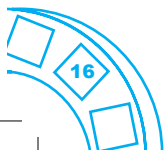

CARATTERISTICHE MECCANICHE

Qualità	ReH (N/mm ²) min	Rm (N/mm ²) sp. < 3	Rm (N/mm ²) sp. > = 3	A % sp. (mm) < 3	A % sp. (mm) > = 3	Resilienza (C°)	Resilienza (J)
S 235 JR	235	360-510	340-470	19	24	20	27
S 235 J0	235	360-510	340-470	19	24	0	27
S235 J2G4	235	360-510	340-470	19	24	-20	27
S 235 J2 G4 (Cu)	235	360-510	340-470	19	24	-20	27
S 275 JR	275	430-580	410-560	16	20	20	27
S 275 J0	275	430-580	410-560	16	20	0	27
S 275 J2 G3	275	430-580	410-560	16	20	-20	27
S 275 J2 G4	275	430-580	410-560	16	20	-20	27
S 275 J2 G4 (Cu)	275	430-580	410-560	16	20	-20	27
S 355 JR	355	510-680	490-630	16	20	20	27
S 355 J0	355	510-680	490-630	16	20	0	27
S 355 J2 G3	355	510-680	490-630	16	20	-20	27
S 355 J2 G4	355	510-680	490-630	16	20	-20	27
S 355 J2 G4 (Cu)	355	510-680	490-630	16	20	-20	27
S 355 K2 G3	355	510-680	0,550	16	20	-20	40

FERRI A 'U'

PROFILI NORMALI

Dimensioni [mm]		Spessore anima [mm]	Spessore ala [mm]	Peso [kg/m]	Modulo di resistenza a flessione W_x [cm ³]
B	H				
30	33	5	7	4,27	4,26
40	35	5	7	4,87	7,05
50	38	5	7	5,59	10,6
65	42	5,5	7,5	7,09	17,7
80	45	6	8	8,64	26,5
100	50	6	8,5	10,60	41,1
120	55	7	9	13,35	60,7
140	60	7	10	16,01	86,4
160	65	7,5	10,5	18,84	116
180	70	8	11	21,98	150
200	75	8,5	11,5	25,28	191
220	80	9	12,5	29,36	245
240	85	9,5	13	33,21	300
260	90	10	14	37,92	371
280	95	10	15	41,84	448
300	100	10	16	46,16	535

PROFILI SPECIALI

Dimensioni [mm]		Spessore anima [mm]	Spessore ala [mm]	Peso [kg/m]	Modulo di resistenza a flessione W_x [cm ³]
B	H				
25	12	4	4	1,30	0,99
30	15	4	4,5	1,74	1,69
35	17	5,5	5,5	2,52	2,71
40	20	5	5,5	2,87	3,79
50	25	5	6	3,86	6,73
60	30	6	6	5,07	10,50

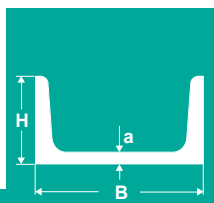

Profilo	Distanza tra gli appoggi [m]										
	2	3	4	5	6	7	8	9	10	11	12
25x12	61	38	26	19	13	-	-	-	-	-	-
30x15	105	67	47	35	26	-	-	-	-	-	-
35x17	169	109	78	59	45	-	-	-	-	-	-
40x20	237	153	110	83	64	-	-	-	-	-	-
30x33	264	169	119	88	65	-	-	-	-	-	-
50x25	423	276	200	153	120	-	-	-	-	-	-
40x35	441	286	206	156	121	-	-	-	-	-	-
60x30	662	433	316	243	194	-	-	-	-	-	-
50x38	667	435	317	243	193	-	-	-	-	-	-
65x42	1119	734	538	418	335	-	-	-	-	-	-
80	1679	1105	813	635	513	424	355	299	253	213	179
100	2609	1722	1273	999	813	677	573	489	420	362	311
120	3858	2550	1889	1487	1215	1016	864	743	643	559	487
140	5498	3638	2701	2132	1747	1468	1254	1085	946	829	729
160	7386	4893	3637	2875	2362	1989	1705	1480	1296	1143	1011
180	9556	6334	4712	3730	3068	2589	2224	1936	1700	1504	1336
200	12173	8073	6011	4763	3923	3316	2854	2489	2192	1944	1734
220	15621	10365	7723	6125	5051	4274	3685	3220	2842	2528	2261
240	19134	12700	9467	7514	6201	5253	4534	3968	3508	3126	2801
260	23668	15716	11720	9308	7687	6519	5633	4935	4370	3900	3502
280	28588	18989	14169	11260	9306	7899	6833	5995	5316	4753	4277
300	34148	22688	16935	13465	11136	9460	8191	7193	6386	5718	5153

Carico in Kg uniformemente distribuito per acciaio con carico di sicurezza $K = 16 \text{ kg/mm}^2$

TRAVI INP

Profilo INP	Dimensioni						Modulo di resistenza a flessione W_x [cm ³]
	Peso [kg/m]	Sezione [cm ²]	h [mm]	b [mm]	a [mm]	e [mm]	
80	5,9	7,57	80	42	3,9	5,9	19
100	8,3	10,6	100	50	4,5	6,8	34
120	11,1	14,2	120	58	5,1	7,7	55
140	14,3	18,2	140	66	5,7	8,6	82
160	17,9	22,8	160	74	6,3	9,5	117
180	21,9	27,9	180	82	6,9	10,4	161
200	26,2	33,4	200	90	7,5	11,3	214
220	31	39,5	220	98	8,1	12,2	278
240	36,2	46,1	240	106	8,7	13,1	353
260	41,9	53,3	260	113	9,4	14,1	441
280	47,9	61	280	119	10,1	15,2	541
300	54,2	69	300	125	10,8	16,2	652
320	61	77,7	320	131	11,5	17,3	781
360	76,1	97	360	143	13	19,5	1087
400	92,5	118	400	155	14,4	21,6	1461
450	115	147	450	170	16,2	24,3	2035
500	141	179	500	185	18	27	2746
600	199	254	600	215	21,6	32,4	4626

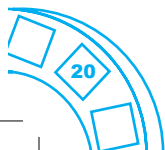

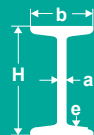

Profilo	Distanza tra gli appoggi [m]										
	2	3	4	5	6	7	8	9	10	11	12
80	1230	810	597	467	378	-	-	-	-	-	-
100	2166	1430	1058	831	678	565	-	-	-	-	-
120	3466	2292	1700	1340	1096	919	783	-	-	-	-
140	5207	3447	2560	2023	1659	1396	1194	1035	904	-	-
160	7452	4938	3672	2906	2389	2014	1729	1503	1319	1165	-
180	10260	6804	5064	4012	3303	2791	2401	2093	1842	1633	1455
200	13644	9052	6743	5347	4408	3730	3214	2808	2477	2202	1968
220	17730	11768	8772	6962	5745	4866	4200	3675	3248	2894	2593
240	22520	14953	11151	8856	7313	6201	5358	4695	4156	3709	3331
270	28140	18690	13944	11080	9157	7771	6721	5895	5226	4671	4201
300	34528	22939	17120	13610	11254	9557	8273	7263	6446	5768	5196
330	41620	27656	20647	16420	13584	11543	9998	8785	7804	6991	6304
360	49862	33140	24748	19689	16295	13854	12008	10559	9387	8417	7599
400	69416	46150	34480	27447	22733	19344	16783	14775	13153	11812	10681
450	93319	62059	46382	36939	30613	26068	22636	19946	17776	15983	14474
500	130010	86482	64660	51521	42723	36406	31640	27907	24898	22415	20327
550	175462	116740	87308	69593	57735	49226	42808	37785	33739	30402	27599
600	295666	196779	147236	117431	97494	83197	72424	64001	57223	51641	46956

Carico in Kg uniformemente distribuito per acciaio con carico di sicurezza $K = 16 \text{ kg/mm}^2$

TRAVI IPE

Profilo IPE	Dimensioni						Modulo di resistenza a flessione W_x [cm ³]
	Peso [kg/m]	Sezione [cm ²]	h [mm]	b [mm]	a [mm]	e [mm]	
80	6	7,64	80	46	3,8	5,2	20
100	8,1	10,3	100	55	4,1	5,7	34,2
120	10,4	13,2	120	64	4,4	6,3	53
140	12,9	16,4	140	73	4,7	6,9	77,3
160	15,8	20,1	160	82	5	7,4	109
180	18,8	23,9	180	91	5,3	8	146
200	22,4	28,5	200	100	5,6	8,5	194
220	26,2	33,4	220	110	5,9	9,2	252
240	30,7	39,1	240	120	6,2	9,8	324
270	36,1	45,9	270	135	6,6	10,2	429
300	42,2	53,8	300	150	7,1	10,7	557
330	49,1	62,6	330	160	7,5	11,5	713
360	57,1	72,7	360	170	8	12,7	904
400	66,3	84,5	400	180	8,6	13,5	1160
450	77,6	98,8	450	190	9,4	14,6	1500
500	90,7	116	500	200	10,2	16	1930
550	106	134	550	210	11,1	17,2	2440
600	122	156	600	220	12	19	3070

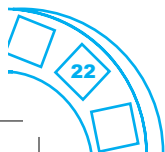



Profilo IPE	Distanza tra gli appoggi [m]										
	2	3	4	5	6	7	8	9	10	11	12
80	1268	835	616	482	391	-	-	-	-	-	-
100	2173	1435	1062	835	681	569	-	-	-	-	-
120	3371	2230	1654	1305	1068	896	765	-	-	-	-
140	4921	3259	2422	1914	1572	1323	1134	983	860	-	-
160	6944	4603	3425	2711	2231	1883	1618	1408	1237	1095	-
180	9306	6173	4597	3644	3002	2538	2186	1907	1681	1492	1332
200	12371	8210	6118	4854	4004	3391	2925	2558	2259	2011	1801
220	16076	10673	7959	6320	5219	4425	3822	3348	2964	2644	2374
240	20675	13732	10245	8141	6728	5710	4938	4332	3840	3432	3088
270	27384	18196	13584	10802	8935	7592	6575	5776	5130	4595	4143
300	35564	23639	17655	14048	11629	9890	8574	7542	6708	6017	5435
330	45534	30274	22620	18007	14916	12694	11015	9699	8635	7757	7016
360	57742	38399	28700	22857	18943	16131	14007	12343	11000	9891	8957
400	74107	49294	36855	29365	24349	20747	18030	15901	14185	12769	11578
450	95845	63767	47690	38012	31534	26885	23379	20635	18424	16601	15069
500	123339	82075	61397	48955	40629	34657	30154	26633	23797	21460	19498
550	155948	103789	77656	61934	51417	43875	38192	33748	30172	27227	24755
600	196236	130621	97752	77982	64761	55283	48144	42564	38076	34382	31283

Carico in Kg uniformemente distribuito per acciaio con carico di sicurezza $K = 16 \text{ kg/mm}^2$

TRAVI HEA

Profilo HEA	Dimensioni						Modulo di resistenza a flessione W_x [cm ³]
	Peso [kg/m]	Sezione [cm ²]	h [mm]	b [mm]	a [mm]	e [mm]	
100	16,7	21,2	96	100	5	8	73
120	19,9	25,3	114	120	5	8	106
140	24,7	31,4	133	140	5,5	8,5	155
160	30,4	38,8	152	160	6	9	220
180	35,5	45,3	171	180	6	9,5	294
200	42,3	53,3	190	200	6,5	10	389
220	50,5	64,3	210	220	7	11	515
240	60,3	76,8	230	240	7,5	12	675
260	68,2	86,8	250	260	7,5	12,5	836
280	76,4	97,3	270	280	8	13	1010
300	88,3	112,5	290	300	8,5	14	1260
320	97,6	124,4	310	300	9	15,5	1480
340	105	133,5	330	300	9,5	16,5	1680
360	112	142,5	350	300	10	17,5	1890
400	125	159	390	300	11	19	2310
450	140	178	440	300	11,5	21	2900
500	155	197,5	490	300	12	23	3550
550	166	211,8	540	300	12,5	24	4150
600	178	226,5	590	300	13	25	4790



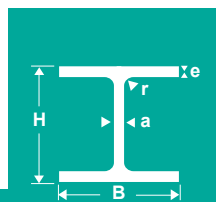

Profilo HEA	Distanza tra gli appoggi [m]										
	2	3	4	5	6	7	8	9	10	11	12
100	4639	3065	2269	1785	1457	-	-	-	-	-	-
120	6744	4463	3312	2614	2142	1799	-	-	-	-	-
140	9871	6539	4861	3845	3158	2661	2282	-	-	-	-
160	14019	9295	6918	5480	4511	3810	3277	2855	2512	-	-
180	18745	12438	9266	7349	6059	5128	4420	3862	3408	3031	-
200	24811	16470	12279	9747	8045	6817	5886	5152	4556	4061	3642
220	32859	21822	16278	12932	10684	9064	7836	6870	6087	5437	4887
240	43079	28619	21359	16979	14038	11921	10318	9057	8037	7191	6476
260	53368	35465	26479	21061	17425	14809	12830	11276	10019	8978	8099
280	64487	42864	32014	25474	21088	17934	15549	13677	12164	10912	9857
300	80463	53495	39967	31815	26350	22422	19454	17125	15245	13691	12380
320	94525	62854	46970	37400	30988	26380	22899	20170	17968	16148	14615
340	107310	71365	53340	42483	35210	29985	26040	22948	20454	18394	16660
360	120736	80304	60032	47824	39648	33776	29344	25872	23072	20761	18816
400	147590	98185	73420	58511	48530	41365	35960	31728	28318	25505	23140
450	185320	123313	92240	73540	61027	52049	45280	39984	35720	32205	29253
500	226890	151002	112980	90105	74803	63829	55560	49094	43890	39604	36007
550	265268	176569	132136	105410	87537	74724	65072	57528	51460	46465	42275
600	306204	203839	152568	121734	101119	86343	75216	66522	59532	53780	48957

Carico in Kg uniformemente distribuito per acciaio con carico di
sicurezza $K = 16 \text{ kg/mm}^2$

TRAVI HEB

Profilo HEB	Dimensioni						Modulo di resistenza a flessione W_x [cm ³]
	Peso [kg/m]	Sezione [cm ²]	h [mm]	b [mm]	a [mm]	e [mm]	
100	20,4	26	100	100	6	10	90
120	26,7	34	120	120	6,5	11	144
140	33,7	43	140	140	7	12	216
160	42,6	54,3	160	160	8	13	311
180	51,2	65,3	180	180	8,5	14	426
200	61,3	78,1	200	200	9	15	570
220	71,5	91	220	220	9,5	16	736
240	83,2	106	240	240	10	17	938
260	93	118,4	260	260	10	17,5	1150
280	103	131,4	280	280	10,5	18	1380
300	117	149,5	300	300	11	19	1680
320	127	161,3	320	300	11,5	20,5	1930
340	134	170,9	340	300	12	21,5	2160
360	142	180,6	360	300	12,5	22,5	2400
400	155	197,8	400	300	13,5	24	2880
450	171	218	450	300	14	26	3550
500	187	238,6	500	300	14,5	28	4290
550	199	254,1	550	300	15	29	4970
600	212	270	600	300	15,5	30	5700

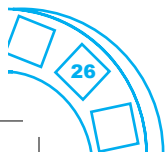

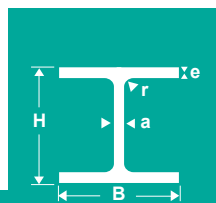

Profilo	Distanza tra gli appoggi [m]										
	2	3	4	5	6	7	8	9	10	11	12
100	5719	3779	2798	2202	1798	1503	-	-	-	-	-
120	9163	6064	4501	3553	2912	2446	2090	-	-	-	-
140	13757	9115	6777	5361	4406	3714	3186	2769	-	-	-
160	19819	13142	9782	7749	6379	5389	4635	4040	3555	-	-
180	27162	18022	13427	10650	8781	7431	6406	5598	4941	4394	-
200	36357	24136	17995	14286	11792	9994	8630	7555	6683	5958	5344
220	46961	31188	23266	18484	15272	12958	11204	9824	8706	7778	6993
240	59866	39772	29683	23597	19511	16570	14342	12592	11174	10000	9007
260	73414	48788	36428	28975	23975	20378	17656	15519	13790	12359	11151
280	88114	58571	43748	34813	28822	24513	21256	18700	16634	14925	13484
300	107286	71329	53292	42423	35138	29901	25944	22840	20334	18262	16516
320	123266	81966	61252	48773	40411	34402	29864	26306	23434	21061	19063
340	137972	91758	68584	54626	45276	38559	33488	29514	26308	23661	21432
360	153316	101974	76232	60730	50348	42892	37264	32855	29300	26365	23896
400	184010	122415	91540	72953	60510	51578	44840	39565	35314	31808	28860
450	226858	150954	112916	90025	74707	63717	55432	48950	43730	39428	35815
500	274186	182479	136532	108889	90398	77137	67144	59330	53042	47863	43516
550	317682	211456	158244	126237	104833	89487	77928	68893	61626	55644	50625
600	364376	242564	181552	144860	120328	102745	89504	79159	70840	63995	58256

Carico in Kg uniformemente distribuito per acciaio con carico di sicurezza $K = 16 \text{ kg/mm}^2$

TRAVI HEM

Profilo HEM	Dimensioni						Modulo di resistenza a flessione W_x [cm ³]
	Peso [kg/m]	Sezione [cm ²]	h [mm]	b [mm]	a [mm]	e [mm]	
100	41,8	53,2	120	106	12	20	190
120	52,1	66,4	140	126	12,5	21	288
140	63,2	80,6	160	146	13	22	411
160	76,2	97,1	180	166	14	23	566
180	88,9	113	200	186	14,5	24	748
200	103	131	220	206	15	25	967
220	117	149	240	226	15,5	26	1220
240	157	200	270	248	18	32	1800
260	172	220	290	268	18	32,5	2160
280	189	240	310	288	18,5	33	2550
300	238	303	340	310	21	39	3480
320	245	312	359	309	21	40	3800
340	248	316	377	309	21	40	4050
360	250	319	395	308	21	40	4300
400	256	326	432	307	21	40	4820
450	263	335	478	307	21	40	5500
500	270	344	524	306	21	40	6180
550	278	354	572	306	21	40	6920
600	285	364	620	305	21	40	7660

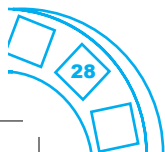

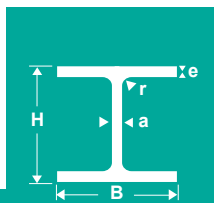

Profilo	Distanza tra gli appoggi [m]										
	2	3	4	5	6	7	8	9	10	11	12
100	12076	7981	5913	4655	3803	-	-	-	-	-	-
120	18328	12132	9008	7112	5831	4902	-	-	-	-	-
140	26178	17346	12899	10206	8389	7073	6070	-	-	-	-
160	36072	23921	17807	14109	11617	9816	8446	7364	6483	-	-
180	47694	31648	23580	18704	15424	13055	11257	9838	8685	7726	-
200	61682	40950	30532	24240	20011	16961	14648	12826	11348	10119	9079
220	77846	51702	38572	30647	25325	21490	18584	16298	14446	12909	11609
240	114886	76329	56972	45295	37458	31815	27544	24187	21470	19218	17316
260	137896	91644	68432	54436	45048	38293	33184	29172	25928	23243	20976
280	162822	108233	80844	64335	53266	45306	39288	34566	30750	27594	24932
300	222244	147766	110408	87898	72812	61968	53776	47351	42164	37877	34264
320	242710	161398	120620	96055	79597	67771	58840	51839	46190	41523	37593
340	258704	172056	128608	102440	84912	72321	62816	55368	49360	44399	40224
360	274700	182717	136600	108830	90233	76879	66800	58906	52540	47286	42867
400	307968	204885	153216	122112	101291	86345	75072	66247	59136	53271	48341
450	351474	233878	174948	139485	115755	98730	85896	75855	67770	61107	55511
500	394980	262870	196680	156858	130220	111116	96720	85463	76404	68943	62680
550	442324	294419	220328	175762	145959	124591	108496	95916	85796	77466	70477
600	489670	325972	243980	194671	161703	138074	120280	106377	95198	86000	78287

Carico in Kg uniformemente distribuito per acciaio con carico di sicurezza $K = 16 \text{ kg/mm}^2$



Taglio a 90°/60°/45° di travi, profilati e laminati

Foratura a C.N., esecuzione di asole e scantonature

Marcatura per incisione caratteri A-Z e numeri 0-9

**Rilascio di certificazioni secondo la normativa
vigente sulle travi e sui ferri a U**



Capacità tecniche

Tubi tondi	fino a Ø 355mm
Tubi quadrati	fino a 260x260mm
Tubi rettangolari	fino a 300x200mm
Profili ad H	IPE 100 - IPE300
	HEA120 - HEA260
	HEB120 - HEB260
	INP100 - INP260
Profili ad U	UPN100 - UPN300
Angolari e elle	da 80x80x8 a 200x200x20mm
Spessori massimi	20mm dritto
	12mm tiltato
Materiale	S235 - S275 - S355
Lunghezza max barre	15mt
Peso massimo barra	100 kg/mt

Taglio laser tubolari e travi



LASERTUBE LT14



TIPOLOGIE DI TAGLIO TRAVI



Figura 1



Figura 2

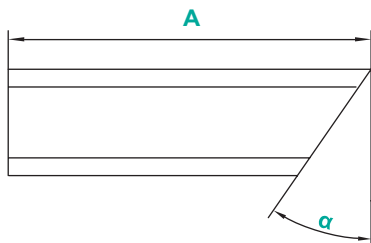

Figura 3

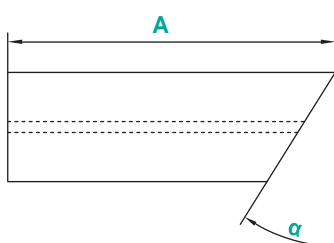

Figura 4

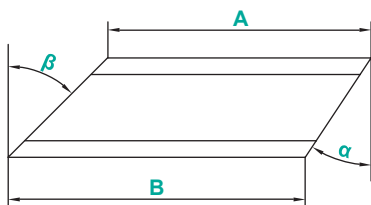

Figura 5

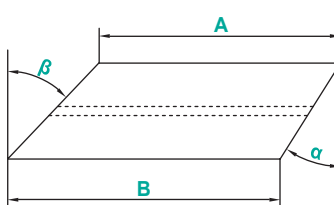

Figura 6

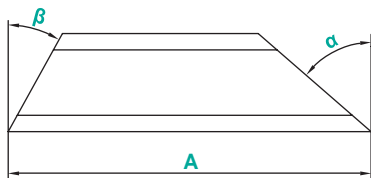

TIPOLOGIE DI TAGLIO FERRI A 'U'

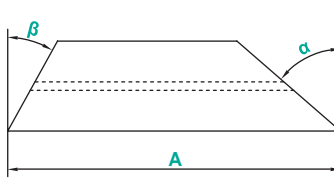

Figura 7



Figura 8

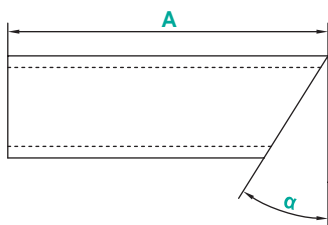
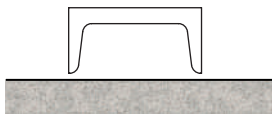

Figura 9

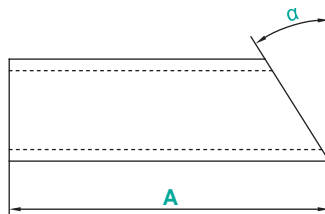

Figura 10

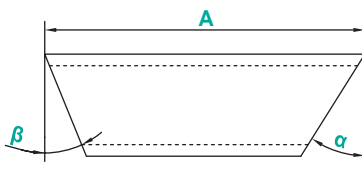

Figura 11

TIPOLOGIE DI TAGLIO FERRI A 'U'

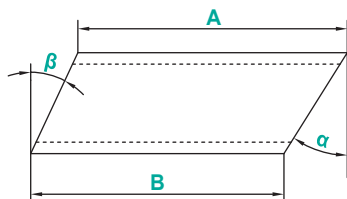

Figura 12

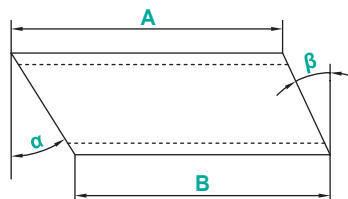

Figura 13

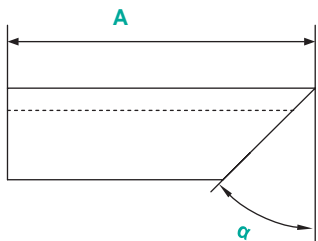

Figura 14

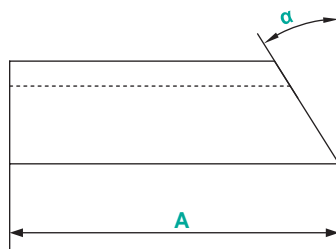

Figura 15

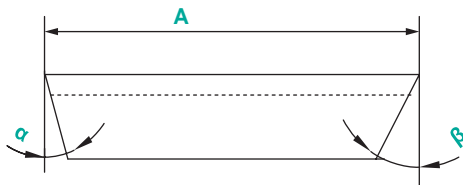

Figura 16

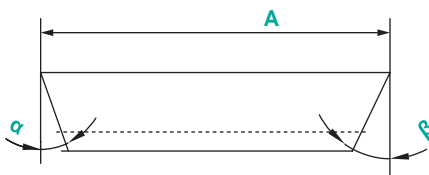

A

POLETTI SpA

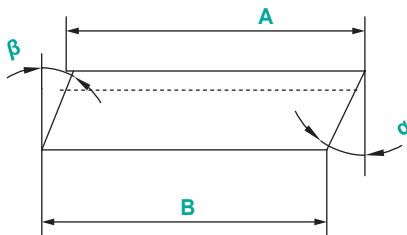
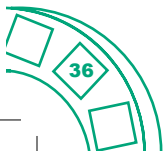

α



TUBI CARPENTERIA NERI E ZINCATI

Diametro [pollici]	Diametro [mm]	Spessore [mm]	Peso neri [kg/m]	Peso zincati [kg/m]
3/8	16,75	1,80	0,68	0,81
1/2	21,25	2,00	0,95	1,18
3/4	26,75	2,35	1,41	1,42
1	33,48	2,65	2,01	2,02
1 1/4	42,25	2,65	2,58	2,71
1 1/2	48,25	2,90	3,25	3,32
2	60,30	2,90	4,11	4,28
2 1/2	76,10	3,00	5,80	6,04
3	88,90	3,00	6,86	7,14
3 1/2	101,60	3,65	8,74	9,10
4	114,30	3,65	9,89	10,03
4 1/2	127,00	4,00	12,20	-
5	139,70	4,00	13,50	-
5 1/2	152,40	4,50	16,36	-
6	168,30	4,50	18,20	-
8	219,10	4,50	23,70	-



TUBI TONDI GAS S/S

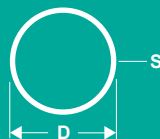

**IN ACCIAIO A VITE E MANICOTTO - SERIE NORMALE
UNI 3824 NERI E ZINCATI**

Diametro [pollici]	Diametro [mm]	Spessore [mm]	Peso [kg/m]
1/8	10,00	1,80	0,37
1/4	13,25	2,00	0,58
3/8	16,75	2,00	0,75
1/2	21,25	2,35	1,11
3/4	26,75	2,35	1,42
1	33,48	2,90	2,23
1 1/4	42,25	2,90	2,87
1 1/2	48,25	2,90	3,30
2	60,00	3,25	4,63
2 1/2	76,00	3,25	5,93
3	89,00	3,65	7,82
3 1/2	102,00	3,65	8,95
4	114,30	4,05	11,30
5	139,07	4,85	16,70
6	168,00	4,85	19,80

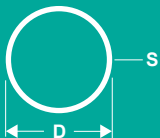

TUBI TONDI GAS SALDATI E F.M.

**IN ACCIAIO - SALDATI ELETTRICAMENTE - A VITE E
MANICOTTO - NERI E ZINCATI**

Diametro [pollici]	Diametro [mm]	Spessore [mm]	Peso neri - lisci [kg/m]
1/8	10	1,8	0,364
1/4	13,25	1,8	0,521
3/8	16,75	1,8	0,680
1/2	21,25	2	0,961
3/4	26,75	2,35	1,420
1	33,48	2,65	2,030
1 1/4	42,25	2,65	2,610
1 1/2	48,25	2,9	3,290
2	60	2,9	4,180
2 1/2	76	3,25	5,400
3	89	3,25	6,310

NB: i tubi saldati e F.M. (Fretz-Moon) vengono provati singolarmente alla pressione idraulica di 60 Kg/cm²



POLETTI SpA



POLETTI SpA

TUBI SALDATI TONDI

DA NASTRO LAMINATO A CALDO

Diametro [mm]	Spessore [mm]							
	1,5	2	2,5	3	4	5	6	7
	Peso [kg/m]							
10	0,69	0,89	-	-	-	-	-	-
12	0,76	0,99	-	-	-	-	-	-
15	0,87	1,14	-	-	-	-	-	-
16	0,98	1,28	1,57	-	-	-	-	-
20	0,69	0,89	-	-	-	-	-	-
22	0,76	0,99	-	-	-	-	-	-
25	0,87	1,14	-	-	-	-	-	-
28	0,98	1,28	1,57	-	-	-	-	-
30	1,06	1,38	1,70	2,00	-	-	-	-
32	1,13	1,48	1,82	2,15	-	-	-	-
35	1,24	1,63	2,01	2,37	-	-	-	-
38	1,35	1,78	2,19	2,59	3,36	-	-	-
40	1,43	1,88	2,31	2,74	3,56	-	-	-
42	1,50	1,98	2,44	2,89	3,75	-	-	-
45	1,61	2,12	2,62	3,11	4,05	-	-	-
48	1,72	2,27	2,81	3,33	4,35	-	-	-
50	1,80	2,37	2,93	3,48	4,54	-	-	-
52	1,87	2,47	3,06	3,63	4,74	-	-	-
55	1,98	2,62	3,24	3,85	5,04	-	-	-
57	2,06	2,72	3,36	4,00	5,23	-	-	-
60	2,17	2,86	3,55	4,22	5,53	-	-	-
65	2,35	3,11	3,86	4,59	6,03	-	-	-
70	2,54	3,36	4,17	4,96	6,52	8,03	9,47	-
76	2,76	3,65	4,54	5,41	7,11	8,77	-	-

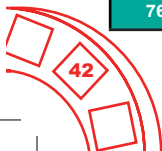

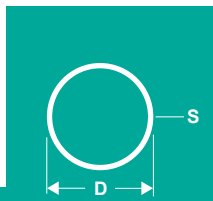

Diametro [mm]	Spessore [mm]							
	2	2,5	3	4	5	6	7	8
	Peso [kg/m]							
80	3,85	4,78	5,70	7,51	9,26	10,96		-
83	4,00	4,97	5,93	7,80	9,63	11,41		-
89	4,30	5,34	6,37	8,40	10,37	12,30	14,17	16,00
102	4,94	6,14	7,33	9,68	11,98	14,22	16,42	-
108	5,23	6,51	7,78	10,27	12,72	15,11	17,46	-
114,3	5,55	6,90	8,24	10,89	13,49	16,05	18,55	21,00
121	5,88	7,32	8,74	11,56	14,32	17,04	19,70	-
127	-	7,69	9,19	12,15	15,06	17,93	20,74	23,51
133	-	8,06	9,63	12,74	15,80	18,82	21,78	24,69
139,7	-	8,47	10,13	13,40	16,63	19,81	22,94	26,02
152	-	-	11,04	14,62	18,15	21,63	25,06	28,45
159	-	-	11,56	15,31	19,01	22,67	26,27	29,83
168,3	-	-	12,25	16,23	20,16	24,05	27,88	31,67
177,8	-	-	12,95	17,17	21,33	25,45	29,52	33,54
193,7	-	-	14,13	18,74	23,30	27,81	32,27	36,68
219	-	-	16,00	21,24	26,42	31,56	36,64	41,68
244,5	-	-	-	23,75	29,57	35,34	41,05	46,72
273	-	-	-	26,57	33,09	39,56	45,98	52,35
323,9	-	-	-	31,60	39,37	47,10	54,78	62,40
339,7	-	-	-	33,16	41,32	49,44	57,51	65,53
355,6	-	-	-	34,73	43,29	51,80	60,26	68,67
406,4	-	-	-	39,75	49,56	59,32	69,04	78,70
457,2	-	-	-	-	55,83	66,85	77,82	88,74
508	-	-	-	-	62,10	74,38	86,60	98,77

TUBI TONDI GS

PER APPLICAZIONI MECCANICHE

Diametro [mm]	Spessore [mm]								
	8	10	12,5	14,2	16	17,5	20	25	30
	Peso [kg/m]								
48,3	8,0	9,5	-	-	-	-	-	-	-
51	8,5	10,1	11,9	-	-	-	-	-	-
54	9,1	10,9	12,8	-	-	-	-	-	-
57	9,7	11,6	13,7	-	-	-	-	-	-
60,3	10,3	12,4	14,8	-	-	-	-	-	-
63,5	11,0	13,2	15,7	-	-	-	-	-	-
67	11,7	14,1	16,8	18,5	20,1	-	-	-	-
70	12,2	14,8	17,7	19,6	21,3	-	-	-	-
76,1	13,5	16,3	19,6	21,7	23,7	-	-	-	-
82,5	14,7	17,9	21,6	23,9	26,3	28,1	30,9	-	-
88,9	16,0	19,5	23,6	26,2	28,8	30,9	34,0	-	-
95	17,2	21,0	25,5	28,3	31,2	33,5	37,0	-	-
101,6	18,5	22,6	27,5	30,6	33,8	36,3	40,3	47,3	-
108	19,8	24,2	29,5	32,9	36,3	39,1	43,5	51,2	-
114,3	21,0	25,8	31,4	35,1	38,8	41,8	46,6	55,1	-
121	22,3	27,4	33,5	37,4	41,5	44,7	49,9	59,3	67,4
127	23,5	28,9	35,3	39,6	43,9	47,3	52,8	63,0	71,9
133	24,7	30,4	37,2	41,7	46,2	49,9	55,8	66,7	76,3
139,7	26,0	32,0	39,3	44,0	48,9	52,8	59,1	70,8	81,3
146	27,3	33,6	41,2	46,2	51,4	55,5	62,2	74,7	85,9
152,4	28,5	35,2	43,2	48,5	53,9	58,3	65,4	78,6	90,7
159	29,8	36,8	45,2	50,8	56,5	61,1	68,6	82,7	95,6

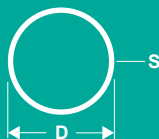

Diametro [mm]	Spessore [mm]									
	10	12,5	14,2	16	17,5	20	25	30	35	40
	Peso [kg/m]									
168,3	39	48	54	60	65	73	88	102	115	127
177,8	41	51	57	64	69	78	94	109	123	136
193,7	45	56	63	70	76	86	104	121	137	152
203	48	59	66	74	80	90	110	128	145	161
219,1	52	64	72	80	87	98	120	140	159	177
229	54	67	75	84	91	103	126	147	168	187
244,5	58	72	81	90	98	111	136	159	181	202
254	-	75	84	94	102	116	141	166	189	211
273	-	80	91	102	110	125	153	180	206	230
298,5	-	88	100	112	121	138	169	199	228	255
305	-	90	102	114	124	141	173	204	233	262
323,9	-	96	109	122	132	150	185	218	250	280
330	-	-	111	124	135	153	188	222	255	286
343	-	-	115	129	141	160	196	232	266	299
355,6	-	-	120	134	146	166	204	241	277	312
368	-	-	124	139	151	172	212	250	288	324
381	-	-	129	144	157	178	220	260	299	337
394	-	-	133	149	163	185	228	270	310	350
406,4	-	-	138	154	168	191	235	279	321	362
419	-	-	142	159	173	197	243	288	332	374

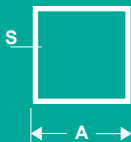

TUBI SALDATI QUADRI

DA NASTRO LAMINATO A CALDO

A [mm]	Spessore [mm]								
	1,5	2	3	4	5	6	7	8	10
Peso [kg/m]									
10	0,34	-	-	-	-	-	-	-	-
12	0,43	-	-	-	-	-	-	-	-
15	0,57	0,70	-	-	-	-	-	-	-
18	0,71	0,90	-	-	-	-	-	-	-
20	0,81	1,02	1,36	-	-	-	-	-	-
25	1,05	1,34	1,83	-	-	-	-	-	-
30	1,28	1,65	2,30	2,84	-	-	-	-	-
35	1,52	1,96	2,77	3,46	-	-	-	-	-
40	1,75	2,28	3,24	4,09	4,83	-	-	-	-
42	1,85	2,41	3,43	4,34	5,14	-	-	-	-
45	1,99	2,60	3,71	4,72	5,61	-	-	-	-
50	2,22	2,91	4,19	5,35	6,40	8,10	-	-	-
60	2,69	3,54	5,13	6,51	7,97	9,45	-	-	-
65	2,93	3,85	5,60	7,24	8,75	10,15	-	-	-
70	-	4,16	6,07	7,86	9,54	11,10	-	-	-
80	-	4,79	7,02	9,12	11,11	12,99	14,74	16,38	-
90	-	5,42	7,96	10,38	12,68	14,87	16,94	18,89	-
100	-	6,07	8,90	11,64	14,26	16,76	19,14	21,41	24,89
110	-	-	9,84	12,89	15,83	18,64	21,34	23,93	28,03
120	-	-	10,79	14,15	17,40	20,53	23,54	26,44	31,17
140	-	-	12,72	16,76	20,52	24,28	27,91	31,43	37,45
150	-	-	13,62	17,92	22,11	26,19	30,14	33,98	40,59
160	-	-	14,61	19,27	23,66	28,04	32,31	36,50	43,73
175	-	-	15,98	21,07	26,04	30,90	35,65	40,27	48,44
200	-	-	17,80	24,29	29,94	35,58	41,10	46,51	56,29
220	-	-	-	26,73	33,12	39,39	45,55	51,49	62,57
250	-	-	-	30,57	37,79	45,00	52,09	59,07	71,99
260	-	-	-	31,76	39,41	46,94	54,35	61,61	75,13
300	-	-	-	-	45,64	54,42	63,08	71,63	87,69
325	-	-	-	39,63	49,62	59,20	68,66	78,00	95,54

TUBI SALDATI RETTANGOLARI

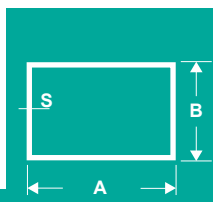

DA NASTRO LAMINATO A CALDO

Dimensioni		Spessore [mm]							
a	b	1,5	2	2,5	3	4	5	6	7
[mm]		Peso [kg/m]							
15	10	0,47	-	-	-	-	-	-	-
20	10	0,59	0,74	-	-	-	-	-	-
20	15	0,71	0,89	-	-	-	-	-	-
25	10	0,71	0,89	-	-	-	-	-	-
25	15	0,83	1,05	-	-	-	-	-	-
25	20	0,94	1,21	1,44	1,65	-	-	-	-
30	10	0,83	1,05	-	-	-	-	-	-
30	15	0,94	1,21	1,44	1,65	-	-	-	-
30	20	1,06	1,36	1,64	1,89	-	-	-	-
30	25	1,18	1,52	1,84	2,13	-	-	-	-
35	10	0,94	1,21	-	-	-	-	-	-
35	15	1,06	1,36	1,64	1,89	-	-	-	-
35	20	1,18	1,52	1,84	2,13	-	-	-	-
35	25	1,30	1,68	2,03	2,36	-	-	-	-
40	10	1,06	1,36	-	-	-	-	-	-
40	15	1,18	1,52	1,84	2,13	-	-	-	-
40	20	1,30	1,68	2,03	2,36	-	-	-	-
40	25	1,41	1,83	2,23	2,60	-	-	-	-
40	30	1,53	1,99	2,42	2,83	-	-	-	-
45	10	1,18	1,52	-	-	-	-	-	-
45	15	1,30	1,68	-	-	-	-	-	-
45	20	1,41	1,83	2,23	2,60	-	-	-	-
45	25	1,53	1,99	2,42	2,83	-	-	-	-
50	10	1,30	1,68	-	-	-	-	-	-
50	15	1,41	1,83	-	-	-	-	-	-

TUBI SALDATI RETTANGOLARI

DA NASTRO LAMINATO A CALDO

Dimensioni		Spessore [mm]							
a	b	1,5	2	3	4	5	6	7	8
[mm]		Peso [kg/m]							
50	20	1,58	2,08	3,02	-	-	-	-	-
50	25	1,70	2,23	3,25	-	-	-	-	-
50	30	1,82	2,39	3,49	4,20	-	-	-	-
50	40	2,05	2,70	3,96	4,83	5,61	-	-	-
60	10	1,58	2,08	-	-	-	-	-	-
60	15	1,70	2,23	-	-	-	-	-	-
60	20	1,82	2,39	3,49	-	-	-	-	-
60	25	1,93	2,55	3,73	-	-	-	-	-
60	30	2,05	2,70	3,96	4,83	-	-	-	-
60	40	2,29	3,02	4,43	5,45	6,56	-	-	-
60	50	2,52	3,33	4,90	6,08	7,34	-	-	-
70	20	2,05	2,70	3,96	-	-	-	-	-
70	25	2,17	2,86	4,20	-	-	-	-	-
70	30	2,29	3,02	4,43	5,45	-	-	-	-
70	40	2,52	3,33	4,90	6,08	-	-	-	-
70	50	2,76	3,65	5,38	6,71	8,13	9,45	10,30	-
80	15	2,17	2,86	-	-	-	-	-	-
80	20	2,29	3,02	4,43	-	-	-	-	-
80	25	2,41	3,18	4,67	-	-	-	-	-
80	30	2,52	3,33	4,90	6,08	-	-	-	-
80	40	2,76	3,65	5,38	6,71	8,13	9,45	10,30	-
80	50	2,99	3,96	5,85	7,34	8,75	-	-	-
80	60	-	4,28	6,32	7,97	9,70	11,30	12,50	-
90	30	-	3,65	5,38	6,71	-	-	-	-
90	40	-	3,96	5,85	7,34	-	-	-	-
90	50	-	4,28	6,32	7,97	-	-	-	-
90	60	-	4,50	6,60	8,59	-	-	-	-
100	20	2,75	3,56	5,19	-	-	-	-	-
100	30	2,95	3,88	5,66	7,34	-	-	-	-
100	40	3,18	4,19	6,13	7,97	9,70	11,30	12,50	13,80
100	50	3,42	4,50	6,60	8,59	10,50	12,30	13,60	15,10

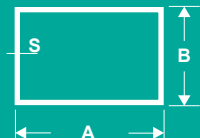

Dimensioni		Spessore [mm]							
a	b	2	3	4	5	6	7	8	10
[mm]		Peso [kg/m]							
100	60	4,82	7,07	9,22	11,30	13,20	14,70	16,40	-
100	70	5,13	7,54	9,85	12,10	14,20	-	-	-
100	80	5,45	8,01	10,50	12,80	15,10	16,90	-	-
110	50	4,82	7,07	9,22	11,30	13,20	-	-	-
120	30	4,50	6,60	8,59	-	-	-	-	-
120	40	4,82	7,07	9,22	11,30	13,20	14,70	16,40	-
120	50	-	7,54	9,85	-	-	-	-	-
120	60	5,45	8,01	10,50	12,80	15,10	16,90	18,90	-
120	80	6,07	8,96	11,70	14,40	17,00	19,10	21,40	-
120	100	-	-	12,99	15,98	19,69	21,58	23,90	-
130	50	5,45	8,01	10,50	12,80	15,10	-	-	-
140	60	6,07	8,96	11,70	14,40	17,00	19,10	21,40	-
140	70	6,39	9,43	12,40	15,20	17,90	-	-	-
140	80	6,70	9,90	13,00	16,00	18,90	21,30	-	-
150	30	5,45	8,22	-	-	-	-	-	-
150	40	5,87	8,73	11,54	-	-	-	-	-
150	50	6,07	8,96	11,70	14,40	17,00	19,10	21,40	-
150	100	-	11,30	14,90	18,30	21,70	24,60	27,70	33,40
160	60	-	9,90	13,00	16,00	18,90	21,30	-	-
160	80	-	10,80	14,20	17,50	20,70	23,50	26,40	-
180	60	-	10,80	14,20	17,50	20,70	23,50	26,40	-
180	80	-	11,80	15,50	19,10	22,60	25,70	28,90	-
180	100	-	-	-	20,69	24,17	28,27	31,43	-
200	100	-	13,70	18,00	22,30	26,40	30,10	33,90	41,30
200	150	-	16,00	21,20	26,20	31,10	35,60	40,20	49,10
250	100	-	16,00	21,20	26,20	31,10	35,60	40,20	49,10
300	100	-	-	24,30	30,10	35,80	41,10	46,50	57,00
300	150	-	-	27,40	34,00	40,50	46,60	52,80	64,80
300	200	-	-	30,60	38,00	45,20	52,10	59,10	-
400	200	-	-	-	45,80	54,70	63,10	71,60	-
400	250	-	-	40,00	49,70	59,40	68,60	77,90	-

TUBO PER SERRAMENTI

1A kg. ml. 1,72

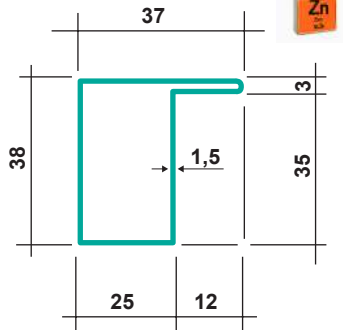

11A kg. ml. 1,34

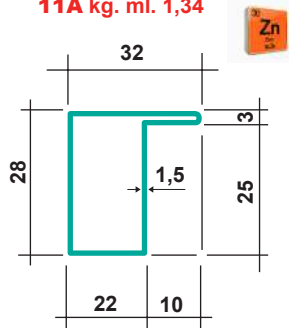

1B kg. ml. 2,10

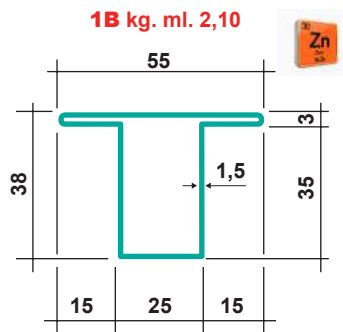

11B kg. ml. 1,57

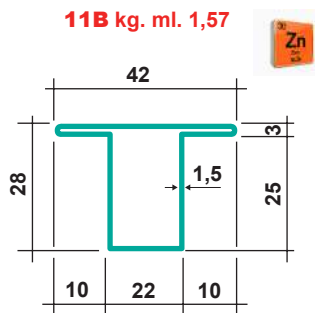

1C kg. ml. 1,99

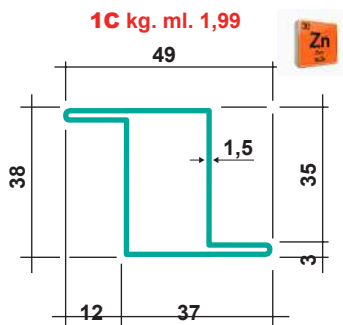

11C kg. ml. 1,57

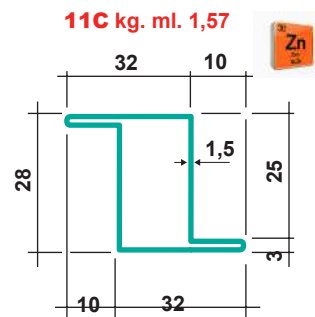



in presenza di questo simbolo il profilo è disponibile anche nella sua variante zincata



T11A kg. ml. 1,7

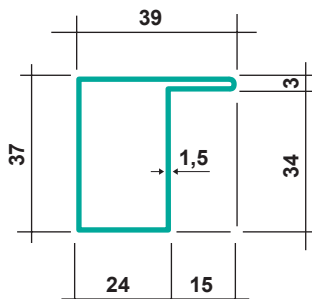

T11B kg. ml. 2,11

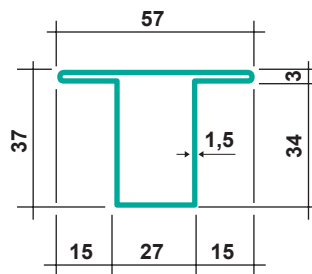

T11C kg. ml. 2,11

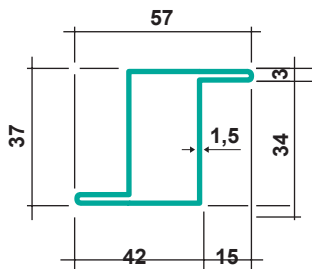

SF 1B kg. ml. 2,15

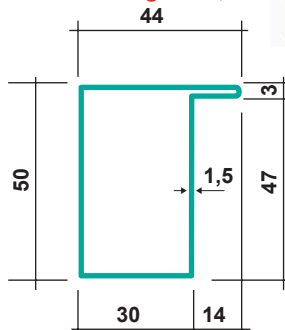

SF 2B kg. ml. 2,52

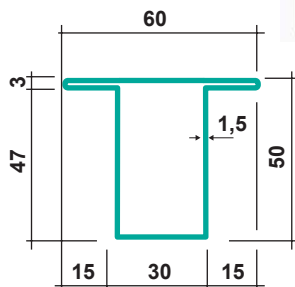

SF 3B kg. ml. 2,52

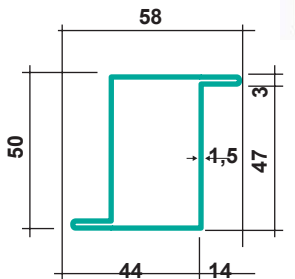

TUBO PER SERRAMENTI

2A kg. ml. 1,76

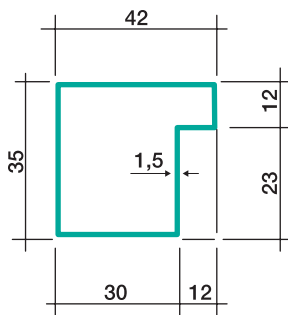

2N kg. ml. 2,30

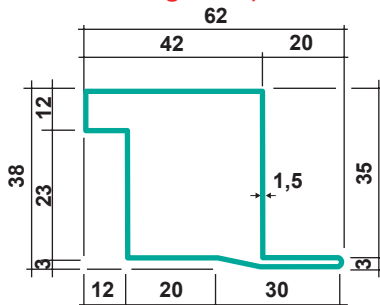

2B kg. ml. 1,88

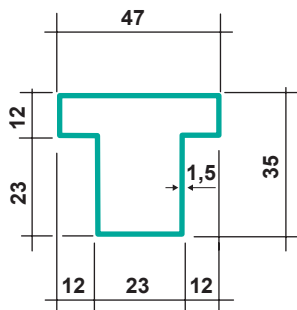

2Z kg. ml. 1,88

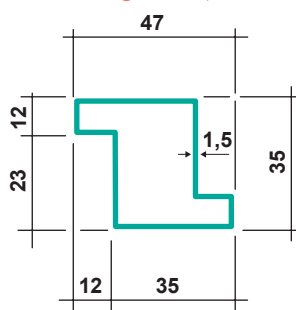

2T kg. ml. 2,30

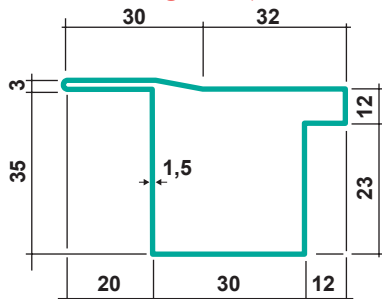

POLETTI SpA



15A kg. ml. 2,04

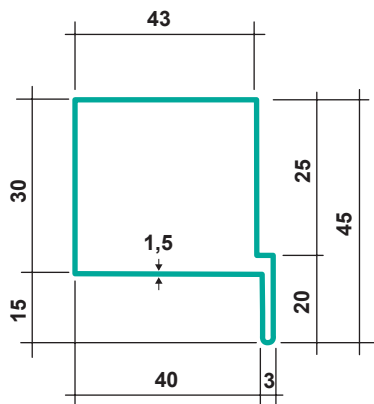

15T kg. ml. 2,45

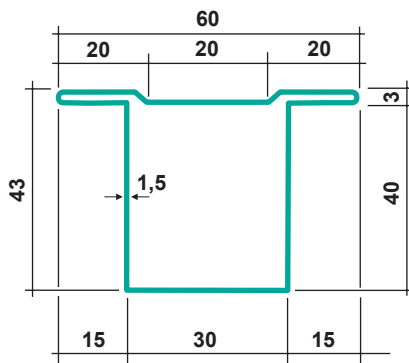

15Z kg. ml. 2,45

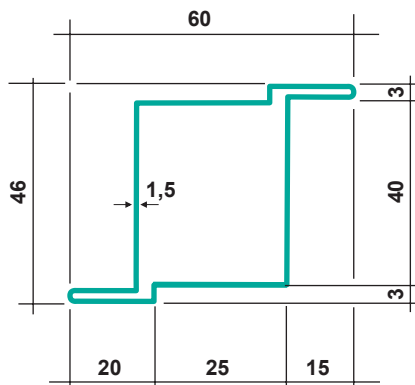

TUBO PER SERRAMENTI

16A sp. 1,5 = **kg. ml. 2,33**
sp. 2 = **kg. ml. 3,08**

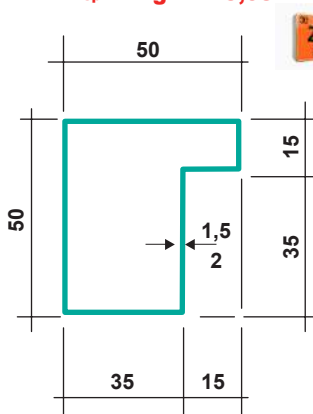

16B sp. 1,5 = **kg. ml. 2,33**
sp. 2 = **kg. ml. 3,08**

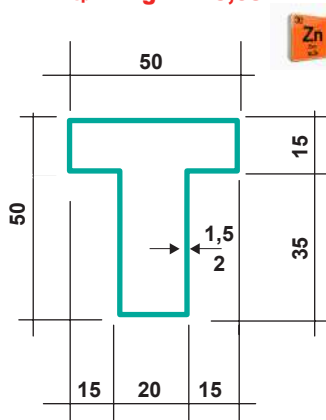

16Z sp. 1,5 = **kg. ml. 2,56**
sp. 2 = **kg. ml. 3,39**

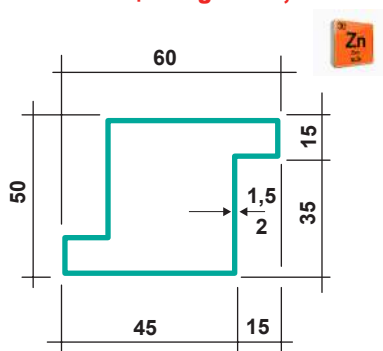

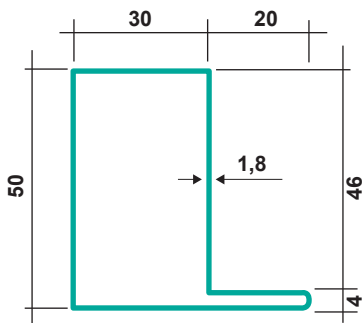
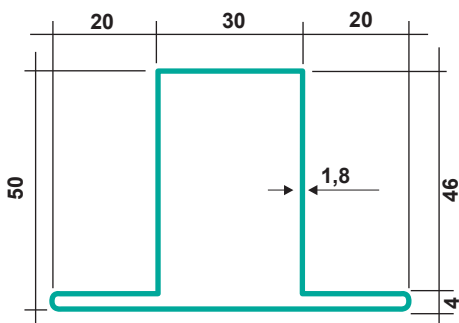
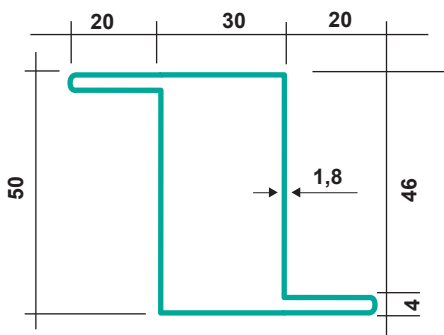
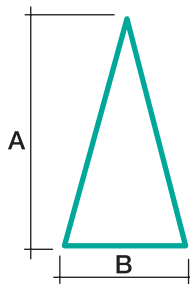
BS M1 kg. ml. 2,80**BS M2 kg. ml. 3,36****BS M3 kg. ml. 3,36****TRIANGOLO ISOSCELE**

A	30	40
B	15	22
1,5	0,87	1,24
2	1,13	1,63

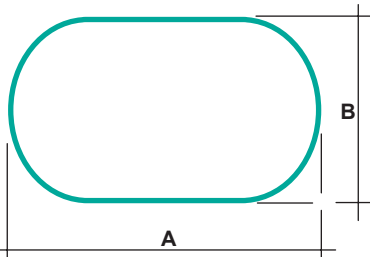
OVALE

A	30	40	50	50
B	15	20	10	25
1,5	0,87	1,11	1,29	1,54
2	1,13	1,5		1,93



TUBOLARE MANOCORRENTE

MT 5

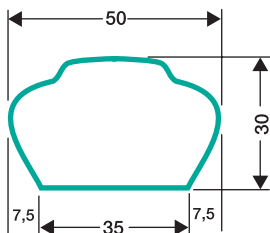

15/10 = kg/ml 1,72

MT 6

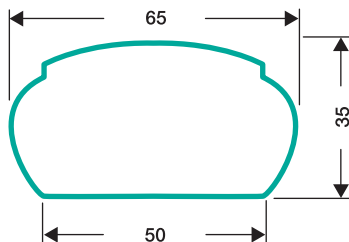

15/10 = kg/ml 2,15

MT 7

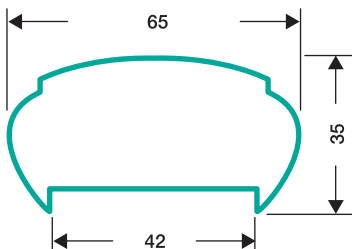

15/10 = kg/ml 2,15

MT 8

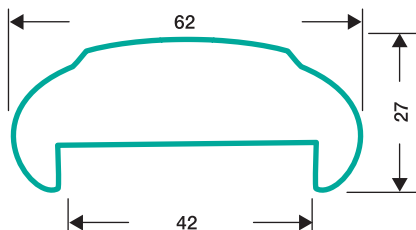

15/10 = kg/ml 1,87

MT 9

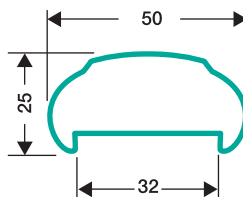

15/10 = kg/ml 1,60

60

POLETTI SpA

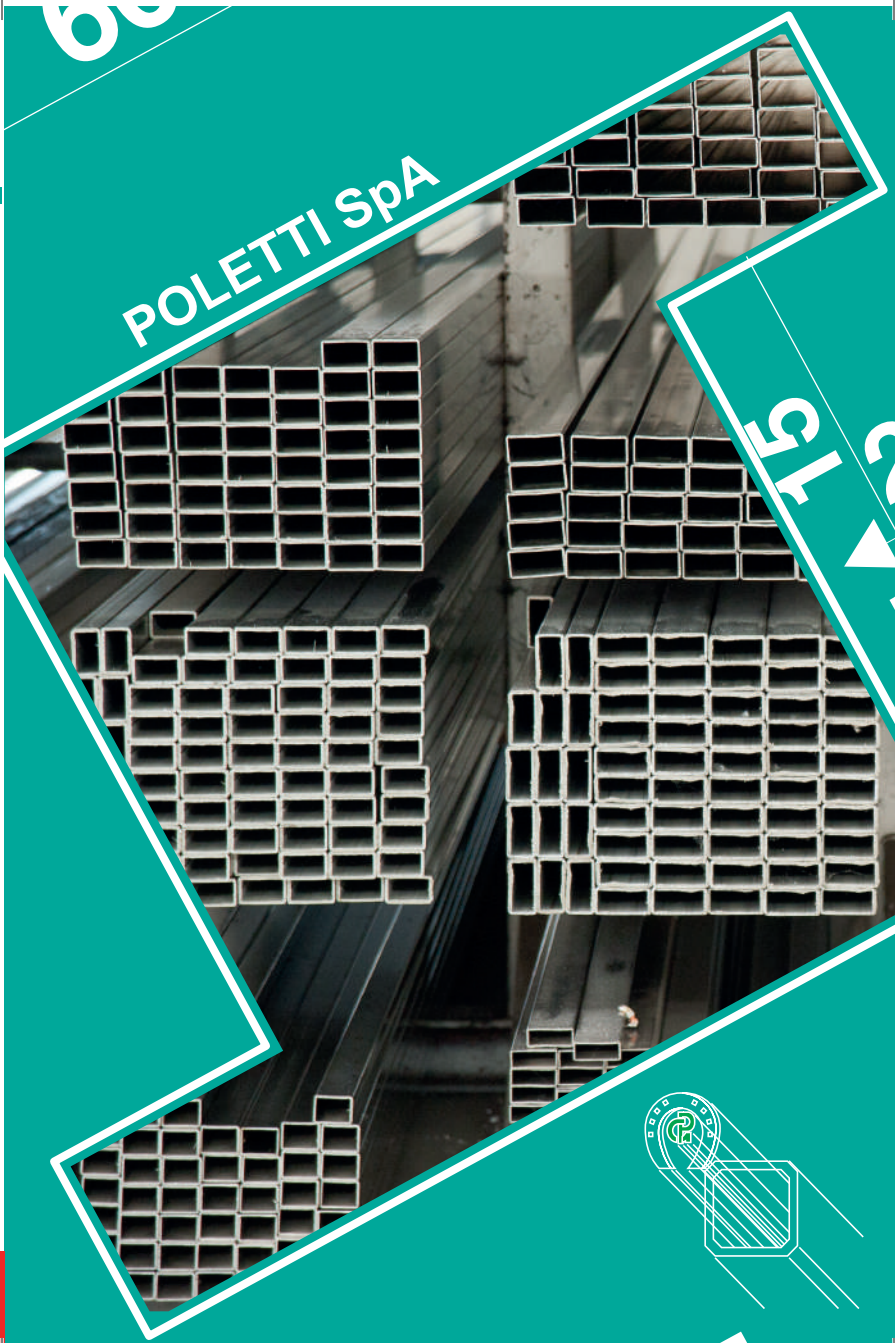

51
2
1



PROFILI PER PERSIANE E PORTE BLINDATE

Tav. 1709 (CL5, asolato e non asolato)

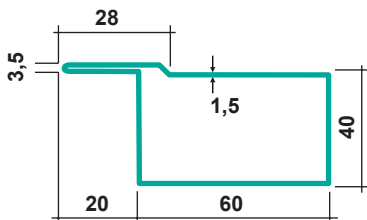

lunghezza: 6 mt - peso: 2,9 kg/mt

CL 2

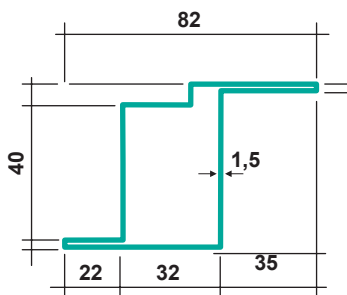

lunghezza 6 mt

Fascia

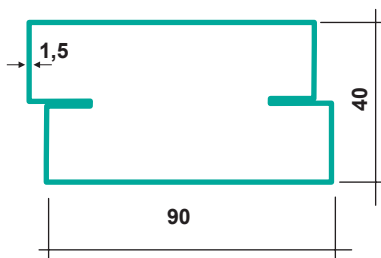

lunghezza 3 mt

Terminale

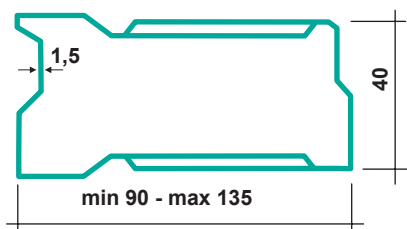

lunghezza 3 mt



POLETTI SpA

PROFILATI A 'C' SIMMETRICI

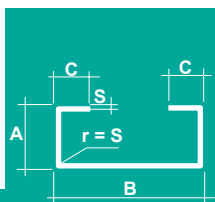

Dimensioni CxAxB [mm]	Spessore [mm]			
	1,5	2	2,5	3
	Peso [kg/m]			
10x20x40	1,09	1,35	-	-
10x30x30	1,15	1,46	1,75	2,00
15x40x40	1,62	2,09	2,53	2,94
20x40x60	-	2,88	3,51	4,12
20x40x80	-	2,97	3,64	4,30
25x50x100	-	3,75	4,58	5,37

'OMEGA' SIMMETRICI

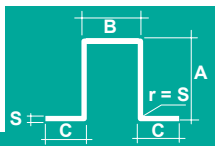

Dimensioni CxAxB [mm]	Spessore [mm]				
	1,5	2	2,5	3	4
	Peso [kg/m]				
20x50x30	-	2,42	3,01	-	-
25x60x40	2,38	3,10	3,80	4,46	-
30x80x40	-	3,90	4,80	5,66	-
30x100x50	-	4,70	5,80	6,84	-
30x120x60	-	5,50	6,80	8,06	10,50
40x150x80	-	7,10	8,80	10,49	13,70

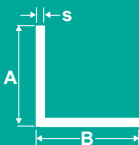

ANGOLARI A LATI UGUALI

PROFILATI A FREDDO

Dimensioni Ax B [mm]	Spessore [mm]						
	1,5	2	2,5	3	4	5	6
	Peso [kg/m]						
20x20	0,43	0,56	0,69	0,84	-	-	-
25x25	0,55	0,72	0,90	1,03	-	-	-
30x30	0,67	0,88	1,10	1,25	-	-	-
35x35	0,82	1,03	1,30	1,53	-	-	-
40x40	0,94	1,20	1,45	1,75	-	-	-
45x45	-	1,35	1,69	2,00	2,63	-	-
50x50	-	1,51	1,87	2,20	2,95	3,65	-
60x60	-	-	2,27	2,70	3,50	4,40	5,22
70x70	-	-	-	3,15	4,15	5,22	6,00
80x80	-	-	-	3,65	4,76	5,87	6,94
90x90	-	-	-	4,12	5,46	6,80	8,10
100x100	-	-	-	4,60	6,00	7,45	8,85

PROFILI ZINCATI PER PANNELLI ISOLANTI

ULS 402 - Kg/mt: 2,94

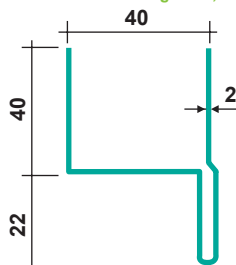

PR 35 - Kg/mt: 3,60

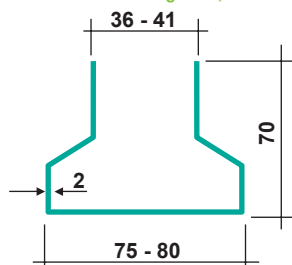

POLETTI SpA



ANGOLARI A LATI DISEGUALI

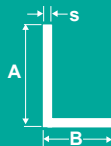

PROFILATI A FREDDO

Dimensioni AxB [mm]	Spessore [mm]						
	1,5	2	2,5	3	4	5	6
	Peso [kg/m]						
30x15	0,50	0,66	0,83	0,99	-	-	-
30x20	0,56	0,75	0,93	1,10	-	-	-
40x20	0,68	0,94	1,14	1,34	-	-	-
40x25	-	0,99	1,22	1,46	-	-	-
40x30	-	1,06	1,32	1,56	-	-	-
50x20	-	1,06	1,32	1,56	-	-	-
50x25	-	1,14	1,42	1,70	-	-	-
50x30	-	1,22	1,52	1,81	-	-	-
60x30	-	1,46	1,72	2,04	-	-	-
60x40	-	1,53	1,90	2,25	2,94	-	-
80x40	-	-	2,30	2,73	3,58	-	-
100x40	-	-	-	3,21	4,22	5,27	-
100x50	-	-	-	3,45	4,54	5,60	-
100x60	-	-	-	3,69	4,86	6,00	-

GUIDA INFERIORE PER CANCELLI SCORREVOLI

ROT 20 (ZINCATA)

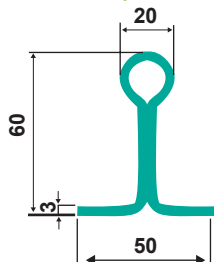

Lunghezza barra: 6 mt

peso: 24 kg

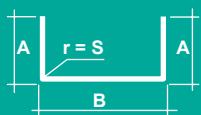

PROFILATI A 'U' AD ALI UGUALI

Dimensioni AxBxA [mm]	Spessore [mm]						
	1,5	2	2,5	3	4	5	6
	Peso [kg/m]						
10x20x10	0,41	0,54	-	-	-	-	-
20x30x20	0,77	1,00	1,22	1,43	-	-	-
20x40x20	0,89	1,16	1,42	1,67	-	-	-
30x50x30	1,25	1,64	2,04	2,43	3,18	-	-
30x60x30	-	1,87	2,20	2,61	3,39	4	-
40x60x40	-	2,10	2,60	3,08	4,01	4,90	-
40x80x40	-	2,41	3,00	3,58	4,73	5,60	-
50x80x50	-	2,73	3,38	4,02	5,27	6,47	-
40x90x40	-	2,57	3,20	3,80	4,96	6,08	-
30x100x30	-	2,41	3,00	3,58	4,73	5,46	-
40x100x40	-	2,73	3,38	4,02	5,27	6,24	-
50x100x50	-	3,04	3,77	4,50	5,90	7,26	8,57
60x100x60	-	3,36	4,17	4,96	6,53	8,04	9,18
50x120x50	-	-	-	4,96	6,53	8,04	9,51
60x120x60	-	-	-	5,44	7,15	8,83	10,45
50x140x50	-	-	-	5,67	7,47	9,22	10,93
60x140x60	-	-	-	5,91	7,78	9,61	11,40
65x160x65	-	-	-	6,55	8,61	10,60	12,80
80x180x80	-	-	-	7,79	10,30	12,75	15,16
100x200x100	-	-	-	9,14	12,07	14,93	17,73
100x220x100	-	-	-	9,60	12,70	15,72	18,70
100x250x100	-	-	-	10,30	13,60	16,90	20,00
100x300x100	-	-	-	-	15,20	18,85	22,42
100x350x100	-	-	-	-	16,89	21,00	25,00
100x400x100	-	-	-	-	18,46	22,96	27,40

PROFILATI A 'U' A LATI UGUALI

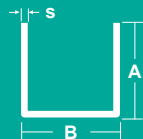

Dimensioni AxBxA [mm]	Spessore [mm]						
	1,5	2	2,5	3	3,5	4	5
	Peso [kg/m]						
20x20x20	0,65	0,83	-	-	-	-	-
25x25x25	0,83	1,00	1,22	1,43	-	-	-
30x30x30	1,00	1,30	1,60	1,90	-	-	-
35x35x35	1,20	1,64	2,04	2,43	-	-	-
40x40x40	-	1,87	2,20	2,61	2,90	3,30	-
45x45x45	-	2,10	2,60	3,08	3,30	3,80	-
50x50x50	-	2,41	3,00	3,58	3,70	4,30	-
60x60x60	-	2,73	3,38	4,02	4,54	5,25	-
70x70x70	-	-	4,00	4,76	-	6,08	-
80x80x80	-	-	-	5,48	6,40	7,11	-

MONOROTAIA

TIPO A (MR1)
peso kg/m 5,00

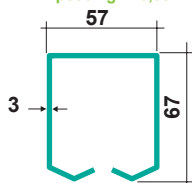

TIPO B (MR2)
peso kg/m 3,20

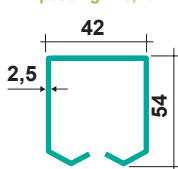

TIPO C (MR3)
peso kg/m 1,72

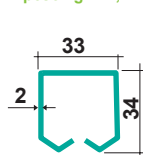

FERMAVETRO A SCATTO

FERMAVETRO 10
peso kg/m: 0,20

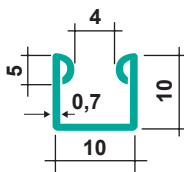

LAMIERE PIANE NERE LUCIDE E ZINCATE

Spessore [mm]	Peso [kg/mq]	1000 x 2000	1250 x 2500	1500 x 3000	1500 x 6000	1800 x 6000	2000 x 6000	2000 x 7000
0,5	3,9	8	-	-	-	-	-	-
0,6	4,7	9	15	-	-	-	-	-
0,7	5,5	11	-	-	-	-	-	-
0,8	6,3	13	20	28	-	-	-	-
1	7,9	16	25	35	-	-	-	-
1,2	9,4	19	29	42	-	-	-	-
1,5	11,8	24	37	53	-	-	-	-
1,8	14,1	28	44	64	-	-	-	-
2	15,7	31	49	71	-	-	-	-
2,5	19,6	39	61	88	177	-	-	-
3	23,6	47	74	106	212	254	283	-
4	31,4	63	98	141	283	339	377	440
5	39,3	79	123	177	353	424	471	550
6	47,1	94	147	212	424	509	565	659
7	55,0	110	172	247	495	593	659	769
8	62,8	126	197	283	565	678	754	879
9	70,7	141	221	318	636	763	848	989
10	78,5	157	245	353	707	848	942	1099
12	94,2	189	295	424	848	1017	1130	1319
15	117,8	236	368	530	1060	1272	1413	1649
18	141,3	283	442	636	1272	1526	1696	1978
20	157,0	314	491	707	1413	1696	1884	2198
25	196,3	393	613	883	1766	2120	2355	2748
30	235,5	471	736	1060	2120	2543	2826	3297
40	314,0	628	-	-	-	-	3768	-
50	392,5	785	-	-	-	-	4710	-
60	471,0	942	-	-	-	-	-	-

LAMIERE IN QUALITA' S275 - S355

Spessore	3	4	5	6	8	10	12	15
Formato	Peso [singolo foglio]							
1500x3000	106	141	177	212	283	353	424	530

LAMIERE STRIATE

(Lo spessore è
misurato «fuori
stria»)



Spessore	Peso [kg/mq]	1000x2000	1250x2500	1500x3000
2,5	24,7	49	77	-
3	28,6	57	89	129
4	36,5	73	114	164
5	44,3	89	138	199
6	52,1	104	163	234
8	67,8	136	212	305
10	83,6	167	261	376
12	99,1	198	310	446

LAMIERE BUGNATE

(Lo spessore è
misurato «fuori
bugna»)



Spessore	Peso [kg/mq]	1000x2000	1250x2500	1500x3000
2,5	22,1	44	69	-
3	26,1	52	81	117
4	33,9	68	106	153
5	41,8	84	130	188
6	49,6	99	155	223
8	65,3	131	204	294
10	81	162	253	365

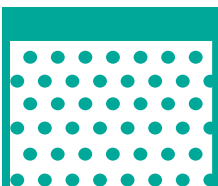

LAMIERE FORATE

DIMENSIONE FOGLI: 1000 X 2000

Spessore [mm]	ø foro (tondo)											
	1	1,5	2	2,5	3	4	5	6	8	10	12	15
0,8	*	*	*	*	*	*	*	*				
1	*	*	*	*	*	*	*	*	*	*		
1,5			*	*	*	*	*	*	*	*	*	*
2					*	*	*	*	*	*	*	*
3						*	*	*	*	*	*	*
4							*	*	*	*	*	*
5								*	*	*	*	*

Disponibile anche:

lamiera **Zn foro ovale 10x20**, spessore 20/10

lamiera **foro quadro 10x10**, spessori 10/10 e 15/10



LAMIERE MANDORLATE



IN ALLUMINIO

Spessore [mm]	Peso [Kg/mq]	1000 x 2000	1250 x 2500	1500 x 3000
3	9,3	18,6	29,1	41,9

LAMIERE IN ACCIAIO PATINABILE S355 J0WP

Disponibile dal pronto nei seguenti formati:

EX CORTEN

1000 x 2000 2, 3, 4 mm

1250 x 2500 2, 3, 4 mm

1500 x 3000 2, 3, 4 mm

altre misure disponibili su richiesta

POLETTI SpA



POLETTI

6

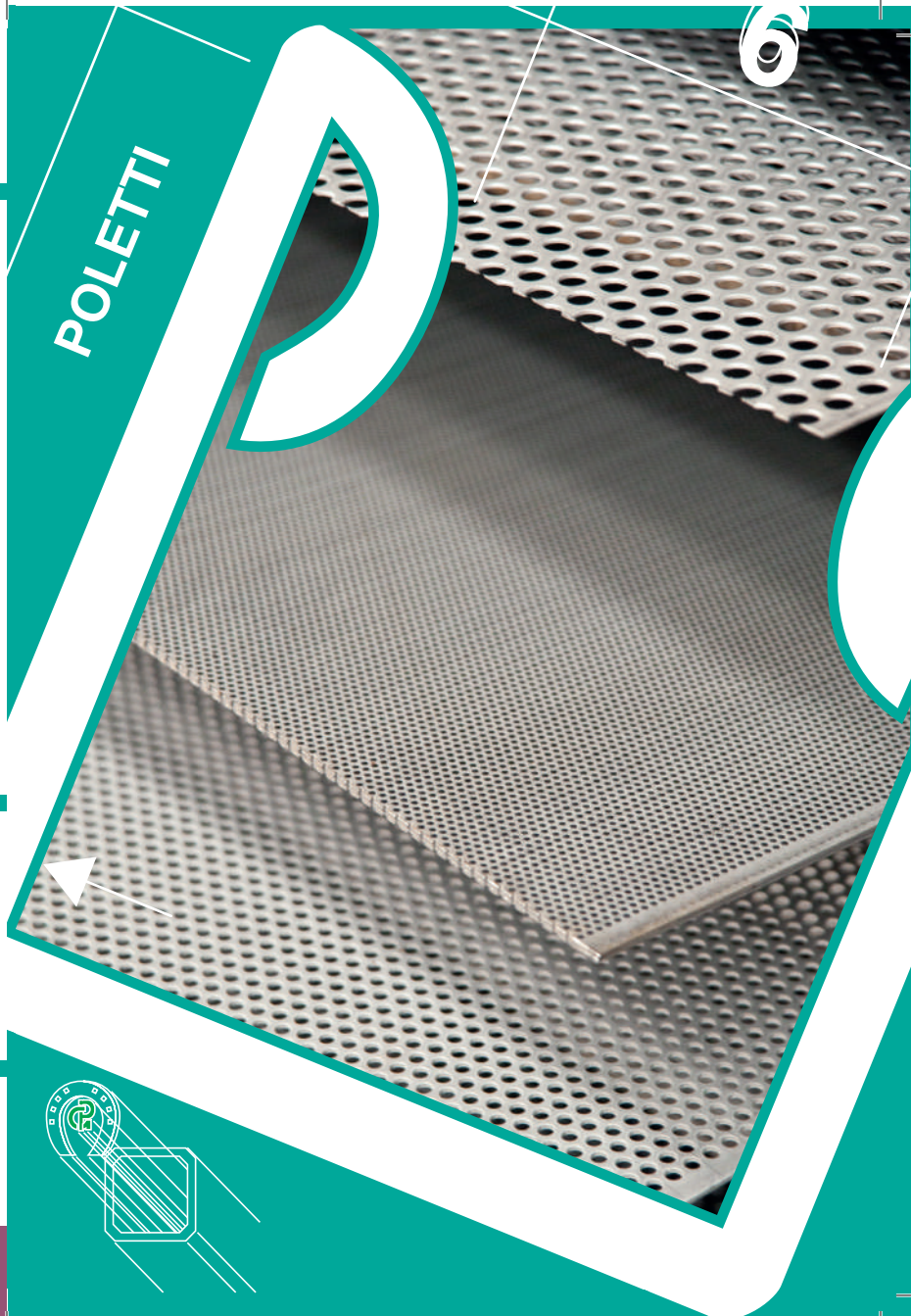

ANALISI INDICATIVA DEI PIU' COMUNI TIPI DI ACCIAIO INOSSIDABILE

DESIGNAZIONE			ANALISI INDICATIVA %									
AIISI	UNI	WERK- STOFF MATE- RIAL	AFNOR	C MAX	CR	Ni	MO	MN MAX	P MAX	S MAX	SI	ALTRI
304	X5 CR Ni 18-10	1,430	Z6 CN 18-09	0,08	18-20	8-10,5		2	0,045	0,030	1	
304 L	X2 CR Ni 18-11	1,431	Z2 CN 18-10	0,03	18-20	8-12		2	0,045	0,030	1	
321	X6 CR Ni Ti 18-11	1,454	Z6 CNT 18-11	0,08	17-19	9-12		2	0,045	0,030	1	Ti= 5 x C min
316	X5 CR Ni MO 17-13	1,440	Z6 CND 17-11	0,06	16-18,5	10,5-13,5	2-2,5	2	0,045	0,030	1	
316 L	X2 CR Ni MO 17-12	1,440	Z2 CND 17-12	0,03	16-18,5	11-14	2-2,5	2	0,045	0,030	1	
316 TI	X6 CR Ni MO TI 17-12	1,457	Z8 CNDT 17-12	0,08	16-18,5	10,5-13,5	2-2,5	2	0,045	0,030	1	Ti= 5 x C min
316 SL	X2 CR Ni MO 17-13	1,444	Z2 CND 17-13	0,03	16-18,5	11,5-15	2,5-3	2	0,045	0,030	1	
310 S	X6 CR Ni 25-20	1,484	Z12 CN 25-20	0,08	24-26	19-22		2	0,045	0,030	1,50	
430	X8 CR 17	1,402	Z8 C 17	0,12	16-18			1	0,040	0,030	1	
430 TI	X6 CR TI 17	1,451		0,08	16-18	0,5		1	0,040	0,030	1	Ti= 5 x C min 0,8 max
409	X6 CR TI 12	1,451	Z6 CT 12	0,080	10-11,5			1	0,045	0,045	1	Ti= 6 x C MIN 0,75 max

LAMIERE ACCIAIO INOX

Spessore [mm]	Peso [kg/mq]	1000	1250	1500
		x 2000	x 2500	x 3000
0,5	4,0	8	-	-
0,6	4,8	10	-	-
0,8	6,3	13	20	-
1	7,9	16	25	36
1,2	9,5	19	30	43
1,5	11,9	24	38	54
2	15,9	32	50	71
2,5	19,8	40	62	89
3	23,8	48	74	107
4	31,7	63	99	143
5	39,7	79	124	178
6	47,6	95	149	214
8	63,4	127	198	285
10	79,3	159	248	357
12	95,2	190	297	428

LAMIERE BUGNATE



Spessore [mm]	Peso [kg/mq]	1000 x 2000
3	25	50

PIATTI ACCIAIO INOX

Larghezza [mm]	Spessore [mm]						
	3	4	5	6	8	10	12
	Peso [kg/m]						
10	0,24	0,32	0,40	-	-	-	-
15	0,36	0,48	0,59	0,71	0,95	1,19	-
20	0,48	0,63	0,79	0,95	1,27	1,59	1,90
25	0,59	0,79	0,99	1,19	1,59	1,98	2,38
30	0,71	0,95	1,19	1,43	1,90	2,38	2,85
35	0,83	1,11	1,39	1,67	2,22	2,78	3,33
40	0,95	1,27	1,59	1,90	2,54	3,17	3,81
45	1,07	1,43	1,78	2,14	2,85	3,57	4,28
50	1,19	1,59	1,98	2,38	3,17	3,97	4,76
60	1,43	1,90	2,38	2,85	3,81	4,76	5,71
70	1,67	2,22	2,78	3,33	4,44	5,55	6,66
80	1,90	2,54	3,17	3,81	5,08	6,34	7,61
90	2,14	2,85	3,57	4,28	5,71	7,14	8,56
100	2,38	3,17	3,97	4,76	6,34	7,93	9,52
110	-	-	4,36	5,23	6,98	8,72	10,47
120	-	-	4,76	5,71	7,61	9,52	11,42
130	-	-	5,15	6,19	8,25	10,31	12,37
140	-	-	5,55	6,66	8,88	11,10	13,32
150	-	-	5,95	7,14	9,52	11,90	14,27
160	-	-	6,34	7,61	10,15	12,69	15,23
180	-	-	7,14	8,56	11,42	14,27	17,13



POLETTI SpA



Larghezza [mm]	Spessore [mm]						
	15	20	25	30	40	50	60
	Peso [kg/m]						
10	-	-	-	-	-	-	-
15	-	-	-	-	-	-	-
20	2,38	-	-	-	-	-	-
25	2,97	3,97	-	-	-	-	-
30	3,57	4,76	5,95	-	-	-	-
35	4,16	5,55	6,94	-	-	-	-
40	4,76	6,34	7,93	9,52	-	-	-
45	5,35	7,14	8,92	10,71	-	-	-
50	5,95	7,93	9,91	11,90	15,86	-	-
60	7,14	9,52	11,90	14,27	19,03	-	-
70	8,33	11,10	13,88	16,65	22,20	-	-
80	9,52	12,69	15,86	19,03	25,38	31,72	38,06
90	10,71	14,27	17,84	21,41	28,55	35,69	42,82
100	11,90	15,86	19,83	23,79	31,72	39,65	47,58
110	13,08	17,45	21,81	26,17	34,89	43,62	52,34
120	14,27	19,03	23,79	28,55	38,06	47,58	57,10
130	15,46	20,62	25,77	30,93	41,24	51,55	61,85
140	16,65	22,20	27,76	33,31	44,41	55,51	66,61
150	17,84	23,79	29,74	35,69	47,58	59,48	71,37
160	19,03	25,38	31,72	38,06	50,75	63,44	76,13
180	21,41	28,55	35,69	42,82	57,10	71,37	85,64

TUBI TONDI ACCIAIO INOX

Diametro [mm]	Spessore [mm]							
	1	1,2	1,5	2	2,5	3	4	5
	Peso [kg/m]							
10	0,224	0,263	0,318	-	-	-	-	-
12	0,274	0,323	0,392	0,498	-	-	-	-
14	0,324	0,383	0,467	0,598	-	-	-	-
15	0,349	0,413	0,504	0,648	-	-	-	-
16	0,374	0,442	0,542	0,698	-	-	-	-
17,2	0,404	0,478	0,587	0,757	0,916	-	-	-
18	0,424	0,502	0,617	0,797	-	-	-	-
19,05	0,450	0,534	0,656	0,850	-	-	-	-
20	0,473	0,562	0,691	0,897	-	-	-	-
21,3	0,506	0,601	0,740	0,962	1,171	-	-	-
22	0,523	0,622	0,766	0,997	-	-	-	-
23	0,548	0,652	0,803	1,046	-	-	-	-
25	0,598	0,712	0,878	1,146	1,401	-	-	-
26,9	0,645	0,768	0,949	1,241	1,520	1,786	-	-
28	0,673	0,801	0,990	1,295	1,588	1,868	-	-
30	0,722	0,861	1,065	1,395	1,713	2,018	-	-
32	0,772	0,921	1,140	1,495	1,837	2,167	-	-
33,7	0,815	0,972	1,203	1,579	1,943	2,294	-	-
34	0,822	0,981	1,215	1,594	1,962	2,317	-	-
35	0,847	1,010	1,252	1,644	2,024	2,392	-	-
38,1	0,924	1,103	1,368	1,799	2,217	2,623	-	-
40	0,972	1,160	1,439	1,893	2,336	2,765	-	-
42,4	1,031	1,232	1,528	2,013	2,485	2,945	3,827	-
44,5	1,084	1,294	1,607	2,118	2,616	3,102	-	-
45	1,096	1,309	1,626	2,143	2,647	3,139	-	-
48,3	1,178	1,408	1,749	2,307	2,853	3,386	4,415	-

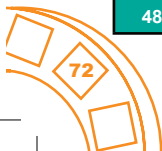

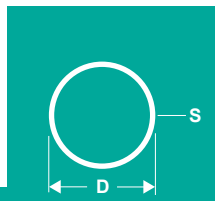

Diametro [mm]	Spessore [mm]							
	1	1,2	1,5	2	2,5	3	4	5
	Peso [kg/m]							
50	1,221	1,459	1,812	2,392	2,958	3,513	4,584	-
50,8	1,241	1,483	1,842	2,431	-	3,572	-	-
51	1,246	1,489	1,850	2,441	3,021	3,587	-	-
52	1,271	1,519	1,887	2,491	3,083	3,662	-	-
54	1,320	1,578	1,962	2,591	3,208	3,812	-	-
57	-	-	2,074	2,740	3,394	4,036	5,282	-
60,3	1,477	1,767	2,197	2,905	3,600	4,283	5,610	-
63,5	1,557	-	2,317	3,064	3,799	4,522	5,929	-
70	1,719	2,057	2,560	3,388	4,204	5,007	6,577	-
76,1	1,871	2,239	2,788	3,692	4,584	5,463	7,185	-
80	1,968	2,356	2,933	3,886	4,827	5,755	7,574	-
88,9	-	-	3,266	4,330	5,381	6,420	8,460	-
101,6	-	-	3,741	4,963	6,172	7,369	9,726	12,033
104	-	-	3,830	5,082	6,322	7,549	9,965	12,332
114,3	-	-	4,215	5,595	6,963	8,318	10,992	13,615
129	-	-	4,765	6,328	7,879	9,417	12,456	15,446
139,7	-	-	5,164	6,861	8,545	10,217	13,523	16,779
154	-	-	5,699	7,574	9,436	11,286	14,948	18,560
168,3	-	-	6,233	8,286	10,326	12,354	16,373	20,341
193,7	-	-	7,182	9,552	11,908	14,253	18,904	23,505
203	-	-	7,530	10,015	12,488	14,948	19,831	24,664
204	-	-	7,567	10,065	12,550	15,022	19,930	24,788
219,1	-	-	8,132	10,817	13,490	16,151	21,435	26,669
273	-	-	-	13,503	16,847	20,179	26,806	-
323,9	-	-	-	16,039	20,017	23,984	31,878	39,724
355,6	-	-	-	17,618	-	26,353	35,037	43,672

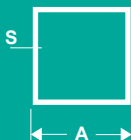

TUBI QUADRI ACCIAIO INOX

Dimensioni [mm]	Spessore [mm]							
	1	1,2	1,5	2	2,5	3	4	5
	Peso [kg/m]							
10x10	0,294	-	-	-	-	-	-	-
12x12	0,358	-	-	-	-	-	-	-
15x15	0,453	0,538	0,661	-	-	-	-	-
16x16	0,485	0,576	0,709	0,920	-	-	-	-
18x18	0,549	0,653	0,805	-	-	-	-	-
20x20	0,613	0,729	0,901	1,176	-	-	-	-
25x25	0,772	0,921	1,140	1,495	1,837	2,167	-	-
30x30	0,932	1,112	1,379	1,814	2,236	2,645	-	-
35x35	1,091	1,304	1,618	2,133	2,635	3,124	-	-
40x40	1,251	1,495	1,858	2,452	3,033	3,602	4,703	-
45x45	1,410	1,686	2,097	2,771	3,432	4,081	5,309	-
50x50	1,570	1,878	2,336	3,090	3,831	4,559	5,979	-
60x60	-	-	2,814	3,728	4,628	5,516	7,255	-
80x80	-	-	3,771	5,004	6,223	7,430	9,807	12,133
100x100	-	-	4,728	6,279	7,818	9,344	12,359	15,323
120x120	-	-	-	7,555	-	11,258	14,910	18,513
150x150	-	-	-	9,469	-	14,129	18,738	23,298
175x175	-	-	-	11,064	-	16,521	21,928	27,285



TUBI RETTANGOLARI ACCIAIO INOX

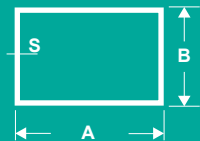

Dimensioni [mm]	Spessore [mm]							
	1	1,2	1,5	2	2,5	3	4	5
	Peso [kg/m]							
20x10	0,453	0,538	0,661	-	-	-	-	-
20x15	0,533	0,634	0,781	-	-	-	-	-
25x15	0,613	0,729	0,901	1,176	-	-	-	-
30x10	0,613	0,729	0,901	-	-	-	-	-
30x15	0,693	0,825	1,020	1,335	-	-	-	-
30x20	0,772	0,921	1,140	1,495	-	-	-	-
35x15	0,760	0,910	1,130	-	-	-	-	-
35x20	0,852	1,017	1,259	1,654	-	-	-	-
40x15	0,852	1,017	1,259	1,654	-	-	-	-
40x20	0,932	1,112	1,379	1,814	-	-	-	-
40x30	1,091	1,304	1,618	2,133	-	3,124	-	-
50x20	1,091	1,304	1,618	2,133	-	-	-	-
50x25	-	1,399	1,738	2,292	-	-	-	-
50x30	1,251	1,495	1,858	2,452	-	3,602	-	-
60x20	-	1,495	1,858	2,452	-	-	-	-
60x30	-	1,686	2,097	2,771	-	4,081	-	-
60x40	-	1,878	2,336	3,090	-	4,559	5,979	-
70x20	-	1,650	2,050	2,710	-	-	-	-
80x40	-	2,261	2,814	3,728	4,628	5,516	7,255	-
80x60	-	-	3,293	4,366	5,426	6,473	8,531	-
100x40	-	-	3,293	4,366	5,426	6,473	8,531	-
100x50	-	-	3,532	4,685	5,824	6,952	9,169	-
100x60	-	-	3,771	5,004	-	7,430	9,807	-
100x80	-	-	-	5,641	-	8,387	11,083	13,728
120x60	-	-	-	5,641	-	8,387	11,083	13,728
120x80	-	-	-	6,279	-	9,344	12,359	15,323
150x50	-	-	-	6,279	-	9,344	12,359	15,323
200x100	-	-	-	9,469	-	14,129	18,738	23,298
200x150	-	-	-	11,064	-	16,521	21,928	27,285
250x100	-	-	-	11,064	-	16,521	21,928	27,285



TONDI E QUADRI ACCIAIO INOX

Diametro o lato [mm]	Tondi	Quadri	Diametro o lato [mm]	Tondi	Quadri
	Peso [kg/m]			Peso [kg/m]	
6	0,22	-	35	7,63	9,71
7	0,31	-	40	9,97	12,69
8	0,40	0,51	45	12,61	16,06
9	0,50	0,64	50	15,57	19,83
10	0,62	0,79	55	18,84	23,99
11	0,75	-	60	22,42	28,55
12	0,90	1,14	65	26,31	33,50
14	1,22	1,55	70	30,52	38,86
15	1,40	1,78	75	34,86	44,61
16	1,59	2,03	80	39,51	50,75
18	2,02	2,57	90	50,45	-
20	2,49	3,17	100	62,28	-
22	3,01	-	110	75,36	-
24	3,59	-	120	89,69	-
25	3,89	4,96	130	105,26	-
28	4,88	-	140	122,07	-
30	5,61	7,14	150	140,13	-



ANGOLARI ACCIAIO INOX

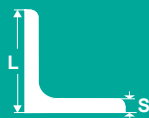

LAMINATI

Dimensioni [mm]	Spessore [mm]						
	3	4	5	6	7	8	10
	Peso [kg/m]						
20x20	0,87	1,14	-	-	-	-	-
25x25	1,11	1,45	-	-	-	-	-
30x30	1,36	1,78	2,17	-	-	-	-
35x35	-	2,09	-	-	-	-	-
40x40	-	2,42	3,00	-	-	-	-
50x50	-	-	3,77	4,46	-	-	-
60x60	-	-	-	5,42	-	-	-
70x70	-	-	-	-	7,54	-	-
80x80	-	-	-	-	-	9,66	11,85
100x100	-	-	-	-	-	-	15,40

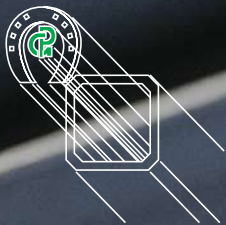



TUBI SERRAMENTO ACCIAIO INOX

1A kg. ml. 1,74

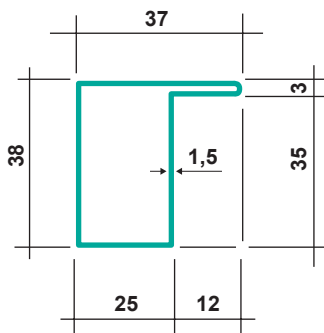

1B kg. ml. 2,20

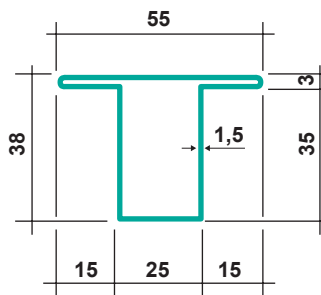

1C kg. ml. 1,97

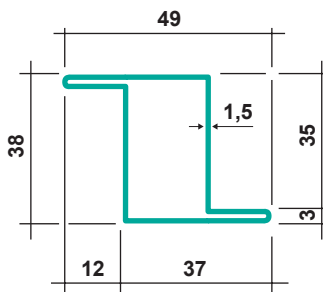

POLETTI SpA

RETE ELETTROSALDATA ACCIAIO INOX

MAGLIA QUADRA

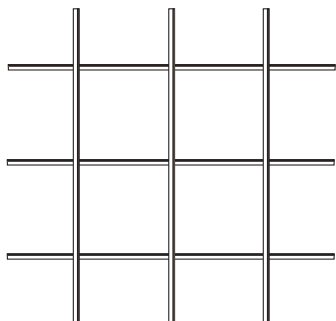

Maglia	Filo Ø	Pannello	Art.
50x50	4	1000x2000	143
50x50	4	1200x2400	142

MAGLIA TEC

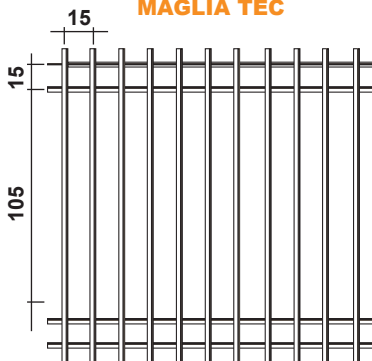

Maglia	Filo Ø	Pannello	Art.
tec	2,85	1000x2000	141
tec	2,85	1200x2400	140

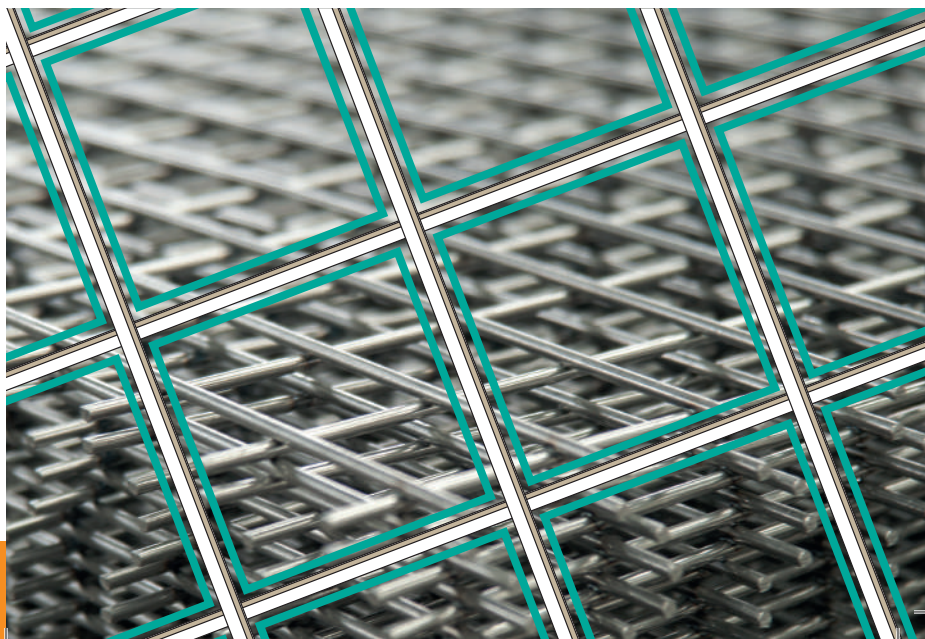

RETE ONDULATA

NERA O ZINCATA



Disponibile in fogli da 1000x2000

Maglia	ø filo mm												
	1,5	2	2,2	2,4	2,7	3	3,5	4	4,5	5	6	7	8
10x10	2,900	4,500											
12x12		3,600	4,300										
15x15			3,800	4,600									
20x20			3,100	3,600	4,500	5,600							
25x25					4,000	4,800	5,600	6,600					
30x30						3,700	4,800	6,300	8,100	9,000			
40x40							3,900	5,300	6,100	7,400			
45x45								4,900	5,900	7,100			
50x50								4,750	5,500	6,900	8,800		
55x55								4,100	4,900	6,300	8,400		
60x60										5,100	7,400		
75x75										4,500	6,400		
80x80											6,100		
100x100											4,300	6,000	9,800

Maglie 10x10; 15x15; 20x20; 30x30; 40x40
 disponibili anche in rotoli da 1000x25000

POLETTI SpA

RETE ELETTROSALDATA

MAGLIA QUADRA

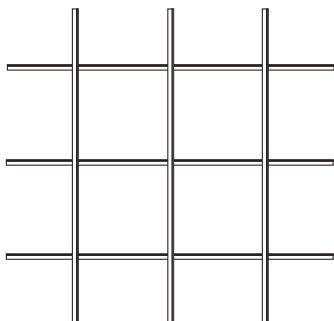

Maglia	Filo Ø	Pannello	Art.
30x30	2,85	1200x2400	7
40x40	4	1200x2400	18
50x50	4	1200x2400	12
50x50	5	1200x2400	15

MAGLIA TEC

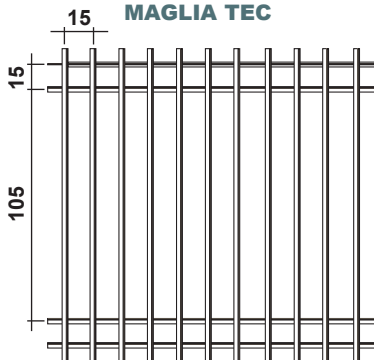

Maglia	Filo Ø	Pannello	Art.
tec	2,85	1200x2400	5

MAGLIA RT

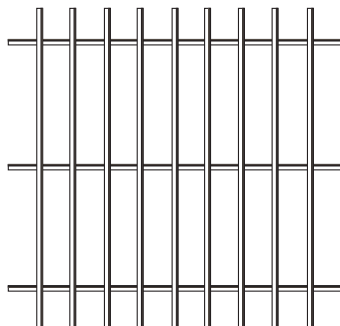

Maglia	Filo Ø	Pannello	Art.
60x11	2,85	1200x2400	6



RETI E GRIGLIATI

RETTANGOLARI STIRATE SPIANATE

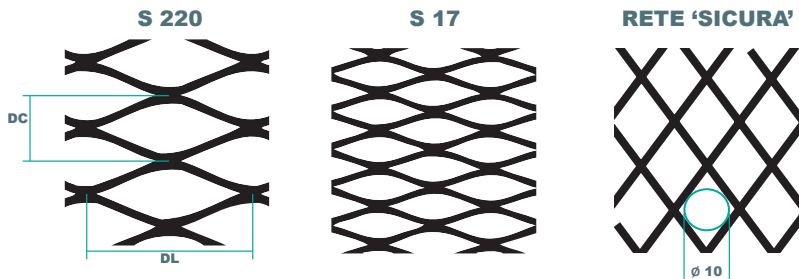

zincata e, a richiesta,
acciaio INOX

RETTANGOLARI STIRATE NON SPIANATE



Indicazione commerciale	DLxDC mm	DLxDC reale mm	AV mm	SP mm	PESO kg/m ²	Larghezza mm	Lunghezza mm
FILS 1 40/10	110x40	110x25,4	7	4	17	1000	2000
FILS 1 30/10	110x40	110x25,4	7	3	13	1000	2000
FILS 21	45x15	45x13,4	4	3	17,5	1000	2000
S 17	43x10	43x14,6	2,5	1,5	4	1000	2000
S 220	60x20	62,5x24,5	3	2	4	1000	2000
SICURA (Zn)	20x13	20x13	1,5	1,5	-	-	-

S220 S17 sono disponibili in rotoli da 1000/1250x6000

Rete 'sicura' è disponibile in rotoli da 1000/1250x25000



POLETTI SpA

GRADINI

GRADINI FILS

SICURFILS ed ECO a bullonare
INDUSTRIA a saldare

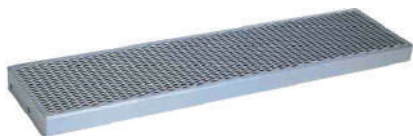

Indicazione commerciale	Tipo Maglia	Larghezza mm	Profondità mm	Altezza mm	PESO cadauno	Portata mm
SICURFILS	Fils 21	1200	300	73	17	510
INDUSTRIA	Fils 21	1000	250	40	10,8	408
INDUSTRIA	Fils 21	800	250	40	6,8	408
BETA	43x10 sp. 3	1200	300	73	11,3	408
ECO	43x10 sp. 2	1000	250	72	5,6	408
ECO	43x10 sp. 2	800	250	72	4,9	408

GRADINI IN GRIGLIATO ELETTROSALDATO ZINCATI

- a bullonare
- con rompivisuale

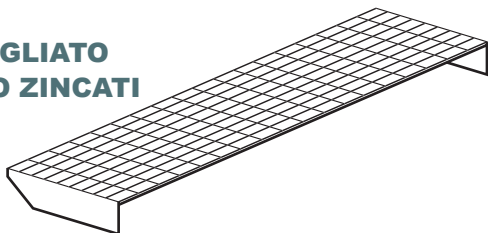

Maglia	Piatto portante	Larghezza (mm)	Profondità (mm)	Peso cadauno (kg)
15x76	25x2	1000	318	9,3
15x76	25x2	1200	318	11,0
15x76	30x2	1200	320	12,7
25x76	25x2	600	205	2,9
25x76	25x2	700	255	4,0
25x76	25x2	800	255	4,5
25x76	25x2	900	255	4,9
25x76	25x2	1000	305	6,3

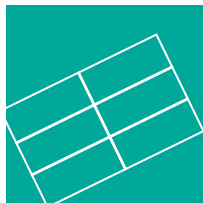

GRIGLIATI ELETTROSALDATI

PER APPLICAZIONI ORIZZONTALI

Bordati e zincati

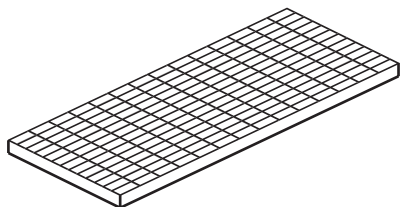

Maglia (a x b)	Piatto portante	Dimensioni (D x B)	Classe di portata	Peso Kg/ cadauno
25x76	25x2	100x1000	classe 4	2,4
		150x1000	classe 4	3,2
		200x1000	classe 3	4,0
		250x1000	classe 2	4,8
		300x1000	classe 1	5,6
		350x1000	classe 1	6,4
		400x1000	classe 1	7,2
		500x1000	classe 1	8,9
		600x1000	classe 1	10,5
		700x1000	classe 1	12,1
		800x1000	classe 1	13,7
		900x1000	classe 1	15,4
1000x1000	classe 1	17,0		

CLASSE 1
CLASSE 2
CLASSE 3
CLASSE 4

FOLLA COMPATTA (pedonale)
AUTOVETTURE
AUTOCARRI LEGGERI
AUTOTRENI/AUTOARTICOLATI



POLETTI SpA

Maglia (a x b)		GREZZO	ZINCATO		
	Piatto portante	Peso Kg/m ²	Peso Kg/m ²	Dimensioni (D x B)	Tipo distanzale
25x25	25x2	17,5	18,7	6100x1000	O
15x76	25x2	24,1	25,8	6100x1000	O
		24,1	25,8	6100x1200	O
	30x2	28,8	30,9	6100x1000	O
		28,8	30,9	6100x1200	O
	40x2	38,3	41,0	6100x1000	O
	25x3	38,1	40,7	6100x1000	O
	30x3	45,7	48,9	6100x1000	O
	40x3	61,0	65,3	6100x1000	O
	50x3	76,3	81,7	6100x1000	O
60x3	91,7	98,1	6100x1000	O	
25x76	25x2	15,2	16,3	6100x1000	O
		15,2	16,3	6100x1200	O
	30x2	18,1	19,3	6100x1000	O
		18,1	19,3	6100x1200	O
	40x2	23,8	25,4	6100x1000	O
	25x3	24,0	25,7	6100x1000	O
	30x3	28,7	30,7	6100x1000	O
	40x3	38,0	40,7	6100x1000	O
	50x3	47,6	50,9	6100x1000	O
	60x3	56,9	60,9	6100x1000	O
	40x4	50,8	54,3	6100x1000	O
	50x4	63,3	67,7	6100x1000	O
60x4	75,9	81,2	6100x1000	O	
34x38	30x3	23,2	24,8	6100x1000	□

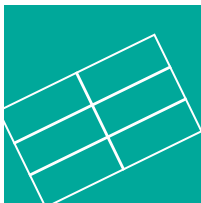

GRIGLIATI ELETTROSALDATI

PER APPLICAZIONI VERTICALI

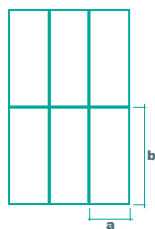
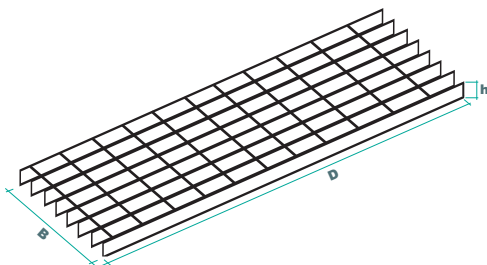

Maglia (a x b)	Piatto portante	GREZZO	ZINCATO		
		Peso Kg/m ²	Peso Kg/m ²	Dimensioni (D x B)	Tipo distanzale
62x66	25x2	9,1	9,8	6072x1560	O
		9,1	9,8	6072x1870	O
62x132	25x2	7,9	8,5	6072x1560	O
		7,9	8,5	6072x1870	O
	25x3	11,1	12	6072x1560	O
		11,1	13	6072x1870	O
124x132	25x3	6,4	6,9	6072x1870	O



RECINZIONI

Maglia (a x b)	Piatto portante	ZINCATO o ZINCATO e VERNICIATO	
		Peso Kg/cadauno	Dimensioni (D x B)
62X66	25x2	20,1	930x1992
		22,5	1064x1992
		25,1	1200x1992
		27,3	1330x1992
		29,7	1460x1992
		34,5	1724x1992
		39,5	1990x1992
		41,9	2110x1992
65x132	25x2	16,4	930x1992
		16,9	1064x1992
		20,1	1200x1992
		22,1	1330x1992
		23,9	1460x1992
		27,6	1724x1992
		31,5	1990x1992
		33,4	2110x1992
124x132	25x3	14,8	930x1992
		16,5	1064x1992
		18,1	1200x1992
		19,9	1330x1992
		21,6	1460x1992
		24,4	1724x1992
		27,8	1990x1992

Per le recinzioni sono disponibili anche:
 piantane **a cementare** (in piatto 60x7 o in angolare 60x60x6)
 piantane **a tassellare** (in piatto 60x7 con piastra 60x140 spessore 8)
bulloni inox (anche **antifurto**)
staffe di compensazione zincate e verniciate 25x5

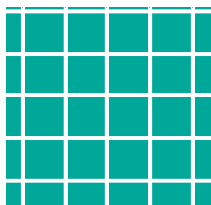

RETE PER EDILIZIA

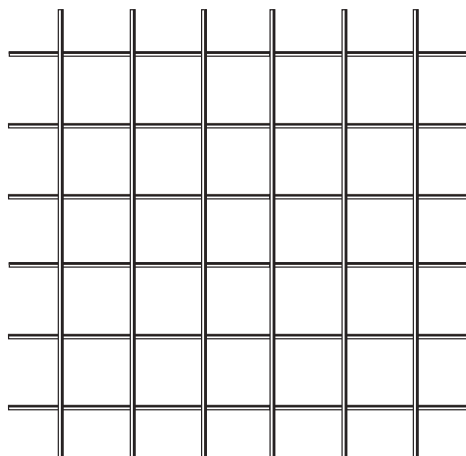

Rete per cemento armato

Dimensioni	Maglia [mm]			
	100x100 f.5	100x100 f.8	150x150 f.5	200x200 f.5
	Peso [kg/mq]			
2000x3000	3,08	7,90	2,10	1,54
2250x4000	3,11	7,98	2,07	1,59

Tondo per cemento armato ad aderenza migliorata o liscio

Peso	Diametro [mm]					
	6	8	10	12	14	16
[kg/mt]	0,22	0,4	0,62	0,88	1,21	1,58





LAMIERE GRECATE

EGB 401/D

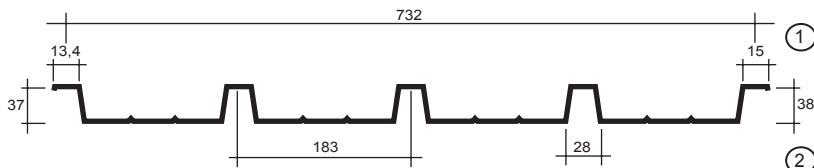

I valori delle portate in **grassetto** tengono calcolo di una freccia <math>< 1/200 \text{ l}</math>

Quando non specificato, la prevencinatura avviene sulla traccia 1

CARATTERISTICHE STATICHE

Spessore	0,6	0,7	0,8	1
Peso Kg/m ²	6,42	7,49	8,57	10,72
J cm ⁴ /m	14,1	16,42	18,76	23,38
W cm ³ /m	4,9	5,72	6,56	8,82

distanza tra gli appoggi in metri

Spessore	1,00	1,25	1,50	1,75	2,00	2,25	2,50	2,75	3,00	3,25	3,50	3,75	4,00
0,6	566	364	253	186	142	112	92	75	62	54	46	40	36
	142				100	73	55	42	33	-	-	-	-
0,7	664	425	296	216	166	131	106	88	74	63	54	47	41
	166				116	85	64	49	39	-	-	-	-
0,8	762	487	336	248	190	150	122	101	85	72	62	54	48
	189				133	96	73	56	46	36	-	-	-
1	952	610	424	311	238	188	153	126	106	90	78	68	60
	236				166	121	91	72	56	44	36	31	26
Freccia cm	0,25	0,39	0,56	0,77	1,00	1,13	1,25	1,38	1,50	1,63	1,75	1,88	2,00

distanza tra gli appoggi in metri

Spessore	1,00	1,25	1,50	1,75	2,00	2,25	2,50	2,75	3,00	3,25	3,50	3,75	4,00
0,6	712	455	316	232	178	140	114	94	79	67	58	51	44
	92				70	55	44	36	29	24	20	17	14
0,7	829	531	369	273	207	164	132	110	92	79	68	59	53
	106				82	64	51	42	34	28	23	19	16
0,8	952	609	422	312	238	188	152	126	106	90	78	68	59
	122				93	73	59	48	39	32	26	22	18
1	1192	763	530	389	298	235	192	158	132	112	97	85	74
	151				116	92	73	59	48	40	33	27	22
Freccia cm	0,19	0,29	0,42	0,58	0,75	0,95	1,17	1,38	1,50	1,63	1,75	1,88	2,00



EGB 210/D

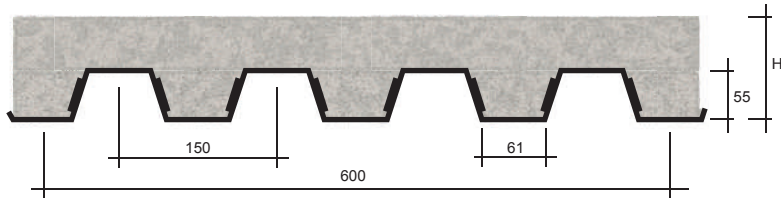

Dimensione fogli: 600x6000 mm - Spessore: 8/10 - Peso: 10,47 Kg/m²

distanza tra gli appoggi in metri

H Soletta cm	Peso Soletta kg/m ²	Spessore mm	Sovraccarico di esercizio utile uniformemente distribuito Kg/m ²															
			2000	1500	1200	1000	800	700	600	550	500	450	400	350	300	250	200	150
9	165	0,8	1,03	1,37	1,72	2,06	2,30	2,42	2,52	2,59	2,67	2,75	2,82	2,92	3,02	3,16	3,29	3,45
		1,0	1,03	1,37	1,72	2,06	2,54	2,67	2,81	2,89	2,97	3,06	3,14	3,27	3,39	3,52	3,68	3,84
		1,2	1,03	1,37	1,73	2,06	2,58	2,91	3,06	3,13	3,23	3,33	3,43	3,56	3,69	3,85	4,02	4,23
10	190	0,8	1,13	1,51	1,88	2,21	2,37	2,47	2,55	2,63	2,70	2,77	2,84	2,95	3,02	3,11	3,22	3,35
		1,0	1,13	1,51	1,88	2,26	2,63	2,74	2,87	2,93	3,01	3,09	3,17	3,26	3,39	3,48	3,60	3,74
		1,2	1,13	1,51	1,88	2,26	2,83	3,01	3,15	3,22	3,32	3,39	3,48	3,59	3,70	3,82	3,95	4,12
11	215	0,8	1,25	1,67	2,08	2,28	2,41	2,50	2,59	2,65	2,70	2,78	2,83	2,90	2,98	3,05	3,14	3,23
		1,0	1,25	1,67	2,08	2,50	2,68	2,78	2,89	2,95	3,01	3,08	3,15	3,23	3,32	3,41	3,51	3,62
		1,2	1,25	1,67	2,08	2,50	2,92	3,03	3,15	3,22	3,29	3,35	3,45	3,53	3,65	3,75	3,84	3,95
12	240	0,8	1,36	1,81	2,18	2,30	2,43	2,51	2,57	2,64	2,67	2,74	2,79	2,85	2,91	2,98	3,05	3,12
		1,0	1,36	1,81	2,27	2,56	2,71	2,82	2,89	2,95	3,02	3,06	3,12	3,19	3,26	3,33	3,42	3,52
		1,2	1,36	1,81	2,27	2,72	2,95	3,05	3,16	3,22	3,27	3,42	3,42	3,48	3,56	3,62	3,73	3,82

distanza tra gli appoggi in metri

H Soletta cm	Peso Soletta kg/m ²	Spessore mm	Sovraccarico di esercizio utile uniformemente distribuito Kg/m ²															
			2000	1500	1200	1000	800	700	600	550	500	450	400	350	300	250	200	150
9	165	0,8	1,03	1,37	1,72	2,06	2,43	2,56	2,70	2,79	2,88	2,98	3,09	3,22	3,36	3,52	3,72	3,95
		1,0	1,03	1,37	1,72	2,06	2,58	2,84	3,00	3,10	3,20	3,31	3,44	3,58	3,75	3,94	4,14	4,41
		1,2	1,03	1,37	1,72	2,06	2,58	2,93	3,26	3,37	3,48	3,60	3,74	3,90	4,08	4,28	4,53	4,81
10	190	0,8	1,13	1,51	1,88	2,25	2,54	2,66	2,80	2,87	2,96	3,05	3,15	3,27	3,39	3,55	3,69	3,88
		1,0	1,13	1,51	1,88	2,26	2,82	2,95	3,11	3,19	3,29	3,39	3,51	3,64	3,78	3,94	4,12	4,33
		1,2	1,13	1,51	1,88	2,26	2,83	3,22	3,42	3,52	3,62	3,73	3,86	4,00	4,15	4,33	4,52	4,76
11	215	0,8	1,25	1,67	2,08	2,43	2,62	2,73	2,88	2,93	3,00	3,09	3,18	3,28	3,38	3,50	3,64	3,78
		1,0	1,25	1,67	2,08	2,50	2,91	3,03	3,18	3,26	3,35	3,45	3,55	3,65	3,75	3,91	4,05	4,23
		1,2	1,25	1,67	2,08	2,50	3,15	3,30	3,46	3,55	3,65	3,75	3,86	3,98	4,12	4,27	4,45	4,63
12	240	0,8	1,37	1,81	2,27	2,47	2,67	2,77	2,89	2,95	3,02	3,10	3,17	3,27	3,37	3,45	3,58	3,68
		1,0	1,36	1,81	2,27	2,72	2,97	3,09	3,22	3,29	3,37	3,45	3,52	3,64	3,72	3,86	3,99	4,12
		1,2	1,36	1,81	2,27	2,72	3,24	3,36	3,52	3,59	3,67	3,77	3,87	3,97	4,09	4,22	4,36	4,52

LAMIERE GRECATE

EGB 4/80

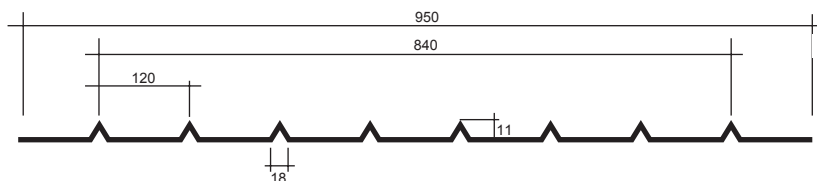

Spessore	0,6	0,7	0,8	1,0
Peso Kg/m	4,71	5,49	6,28	7,85
Peso Kg/m ²	5,60	6,53	7,47	9,34

Disponibile in fogli da 2000 - 2500 - 3000

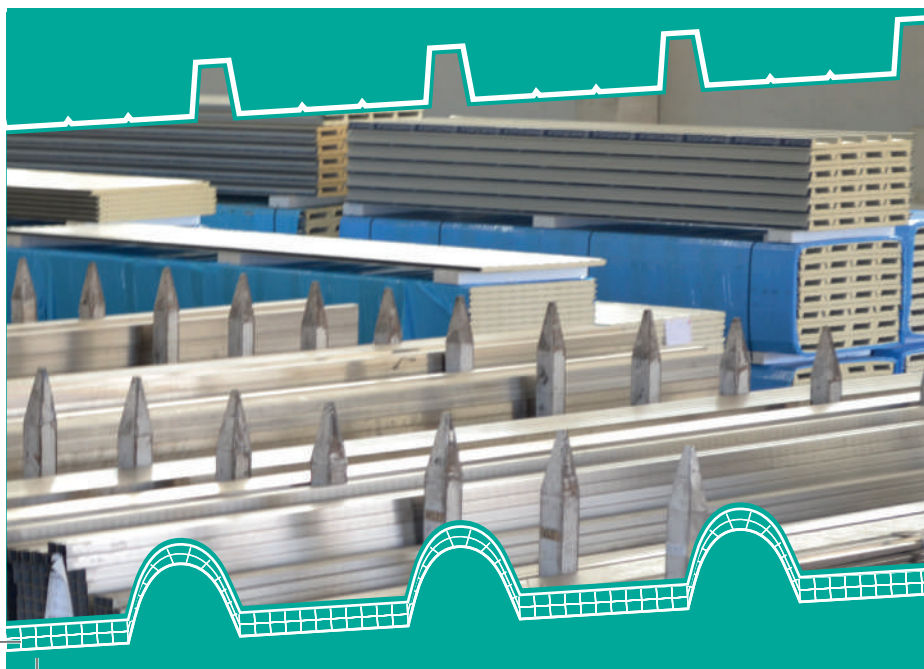

POLICARBONATO PER COPERTURE



GrecaPIU' 40/10 5 greche

Sezione lastra

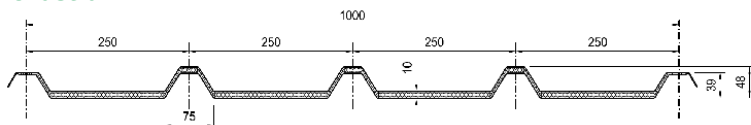

Applicazione

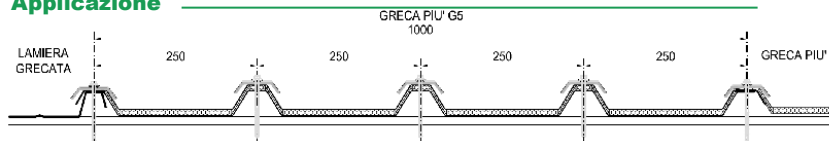

REALIZZAZIONE DI COPERTURE PIANE E CURVE (R3500 e R6000) CON LASTRE GRECATE ESTRUSE IN POLICARBONATO ALVEOLARE A 5 GRECHE CON PASSO 1000 mm, ALVEOLO A NIDO D'APE, PROTETTA AI RAGGI U.V. SUL LATO ESTERNO. LA GRECATURA HA LE SEGUENTI CARATTERISTICHE:

- GRECHE H. ESTERNA = GRECA DI SORMONTO 39 mm
- GRECA CENTRALI 48 mm per abbinamento con lamiera grecate e pannelli sandwich
- PASSO GRECA 250 mm (5 GRECHE SU PASSO 1000 mm)

SPESSORE
PASSO LASTRA
LUNGHEZZA LASTRA
COLORE
CHIUSURE ALL'ESTREMITA'
DATI TECNICI

10 mm (alveolo a nido d'ape)
1000 ± 5mm
possibilità di lunghezze a misura
neutro con finitura satinata e opalino
termosaldate
- protette anti u.v. sul lato esterno
- classe di reazione al fuoco: B s1 d0
(classe 1 italiana)

PROPRIETA' TERMOISOLANTE
PASSAGGIO LUCE
FATTORE SOLARE
COEFFICIENTE OMBREGGIANTE
NOTE DI APPLICAZIONE

$U = 2,50 \text{ W/m}^2\text{K}$
neutro: $58\% \pm 2$ - opalino: $40\% \pm 2$
neutro: $64\% \pm 2$ - opalino: $48\% \pm 2$
neutro: 0,75 - opalino: 0,56



POLETTI SpA

95

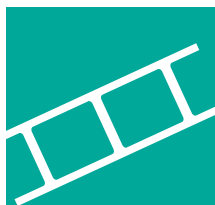

POLICARBONATO ALVEOLARE

STRUTTURA SPESSORE 6 - 8



Spessore	Peso/m ²	Dimensioni
6	1,3	6000x2100
6	1,3	3000x2100
8	1,5	6000x2100
8	1,5	3000x2100

STRUTTURA SPESSORE 10

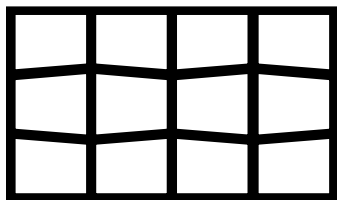

Spessore	Peso/m ²	Dimensioni
10	1,75	6000x2100
10	1,75	3000x2100

STRUTTURA SPESSORE 16

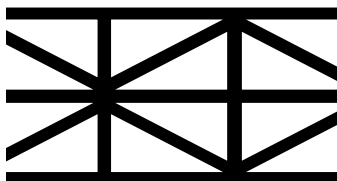

Spessore	Peso/m ²	Dimensioni
16	2,5	6000x2100

Disponibili dal pronto in colore trasparente.

A richiesta è possibile avere altri colori.

Sempre su richiesta è possibile avere altri spessori ed altre lunghezze.



POLETTI SpA

POLICARBONATO COMPATTO E ACCESSORI

LASTRE POLICARBONATO COMPATTO

Spessore mm	Tipo	Dimensioni
3	UV protetto sui due lati	3050x2050
4	UV protetto sui due lati	3050x2050
5	UV protetto sui due lati	3050x2050
6	UV protetto sui due lati	3050x2050

CHIUSURE AD 'H' E AD 'U'

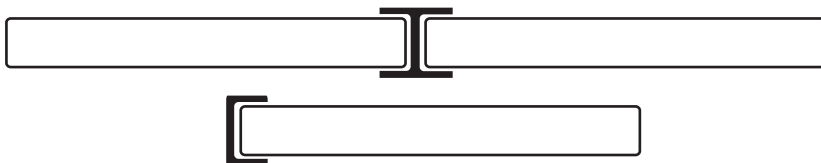

Lunghezza chiusure ad U: 2100 mm

Lunghezza chiusure ad H: 6000 mm

PANNELLI PER PARETI

WIND35 in poliuretano finitura dogata

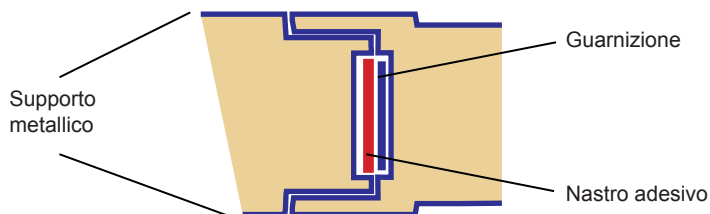
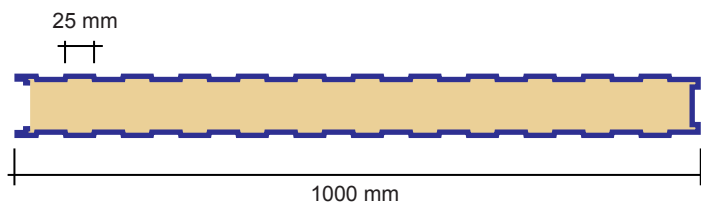

Spessore pannello mm	Spessore supporto mm	Peso Kg/m ²	Reazione al fuoco	Schiuma
40	0,35/0,35	6,60	F	PUR



PANNELLI PER COPERTURE



RAIN30 in poliuretano

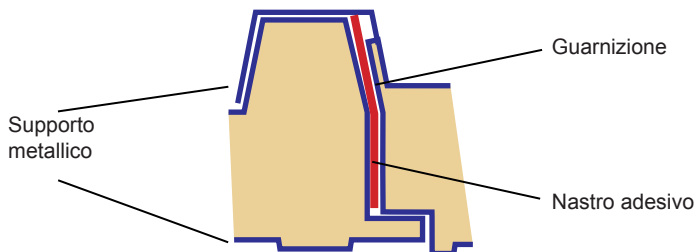
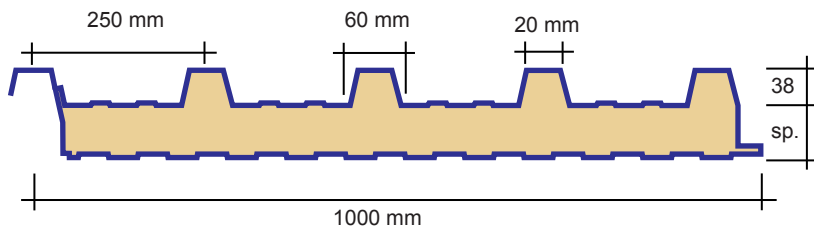

Spessore pannello mm	Spessore supporto mm	Peso Kg/m ²	Reazione al fuoco	Schiuma
30	0,35/0,35	6,90	F	PUR

PANNELLO COPPO

Finto Coppo

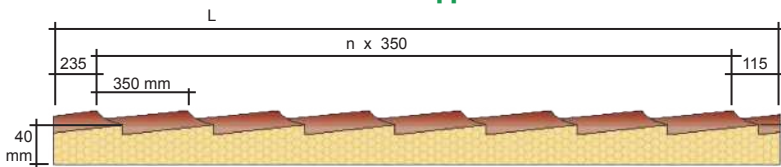

Guarnizione

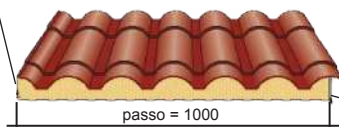

passo = 1000



Tampone dentellato

- ◆ Lunghezza: su richiesta del cliente fino ad un massimo di 13.650 mm (**misure multiple di 350 mm**)
- ◆ Passo utile: 1000 mm
- ◆ Spessore S : 40 mm
- ◆ Spessori lamiera esterna : 0,5 mm - lamiera interna : 0,4 mm
- ◆ Sviluppo lamiera esterna : 1220 mm - interna : 1070 mm
- ◆ Nr. onde lamiera esterna : 6 - Altezza onda lamiera esterna : 40 mm
- ◆ Passo delle onde : 166,66 mm

ISOLAMENTO: Schiuma poliuretanicca rigida

- ◆ Conduttività termica dichiarata $\lambda = 0,021$ Watt/m K
- ◆ Anigrosopico in quanto a celle chiuse per oltre il 95%
- ◆ Coefficiente di trasmittanza termica U: 0,46
- ◆ Densità totale dell'isolante 38 kg/m³ ± 2



Carico massimo uniformemente distribuito
Kg/m² acciaio (campata multipla)

Spessore pannello mm	Spessore supporto mm	Peso Kg/m ²	Reazione al fuoco	Schiuma
40	0,50/0,35	8,30	F	PUR

POLETTI SpA



COLMI



**Colmo fustellato a cerniera in
acciaio preverniciato**

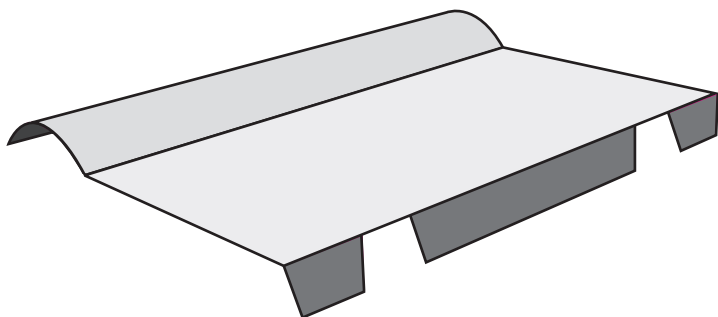
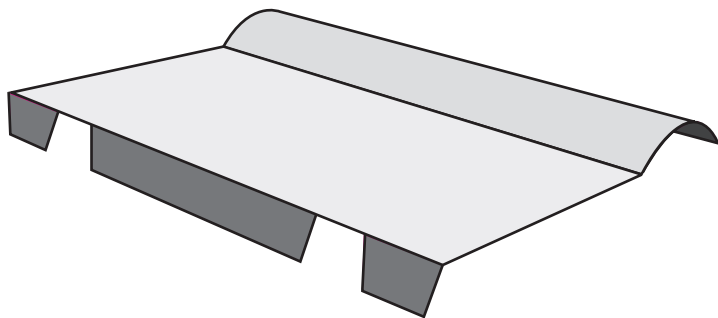

LUNGHEZZA: 3,1 m

COLORI DISPONIBILI: bianco-grigio / rosso coppo

Disponibili anche i relativi gruppi di fissaggio

Disponibili anche i FRONTALINI



FERRAMENTA

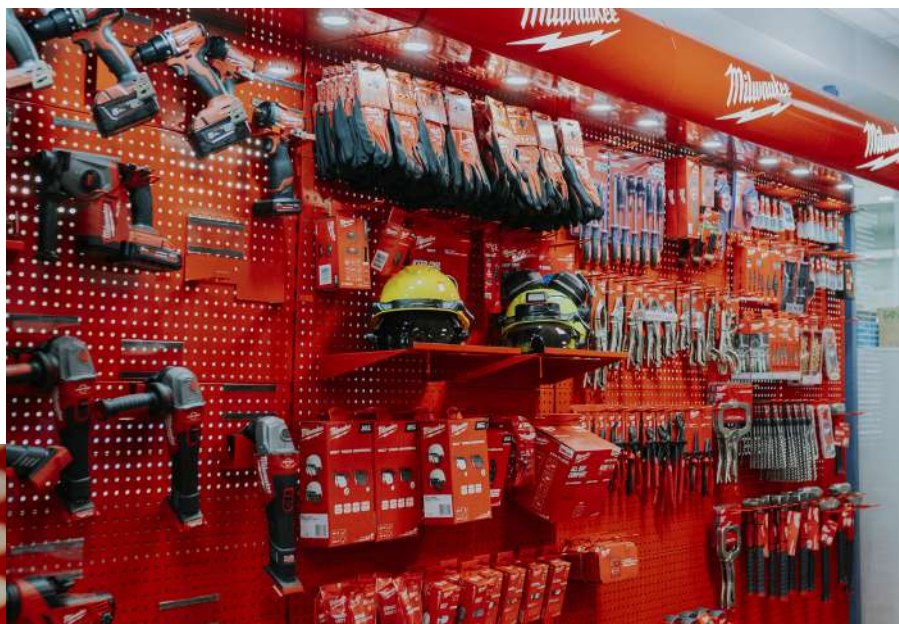



ARTICOLI PER CARPENTERIA

Poletti

CA

combia
accessories & hardware



POLETTI

103



NOTE

