

6 *lue*

AM SERIES  
DIE-SPLITTERS





# QUALITY, INNOVATION AND TRADITION

MILLUTENSIL is a worldwide leader in the production of **die-mould spotting presses** and **die-splitters** which facilitate safe adjusting, checking and maintenance operations. Founded in 1955, Millutensil always puts the customer first by engineering innovative, first-rate solutions based upon the needs of their customers. In working with top-tier companies across a variety of sectors, Millutensil strives for excellence by developing innovative solutions through cutting-edge technologies. Rather than solely taking on the role of a supplier, Millutensil aims to be partners with their customers, by providing trusted advice and reliable assistance.

## WHY TO INVEST IN A DIE-SPLITTER?

Some of the fundamental advantages of using a Millutensil die-splitter are as follows:

- Considerable reduction of die production costs thanks to time and workforce efficiency
- Dies and moulds retain higher quality and longer service life
- Improved safety of both on-site personnel and the die itself while reducing liability of dangerous lifting methods (cranes, forklift trucks or lifting equipment)
- Optimal accessibility and ergonomics by means of swivelling and tilting plates
- Control of parallelism through high-precision linear scales
- Sequencing of hydraulic slides, auxiliary cylinders
- Streamlined operation through intuitive controls of the next generation Siemens Touch Panel
- Modern Diagnostic System

# AM | DIE-SPLITTERS

*Safe and fast splitting  
of your dies!*



# THE BEST SOLUTION FOR SAFE SPLITTING, ADJUSTING, MAINTENANCE AND TRY-OUT OPERATIONS ON DIES



Slide in

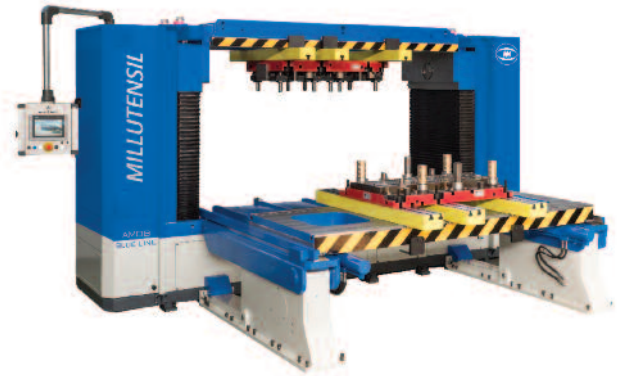

Opening



Rotating

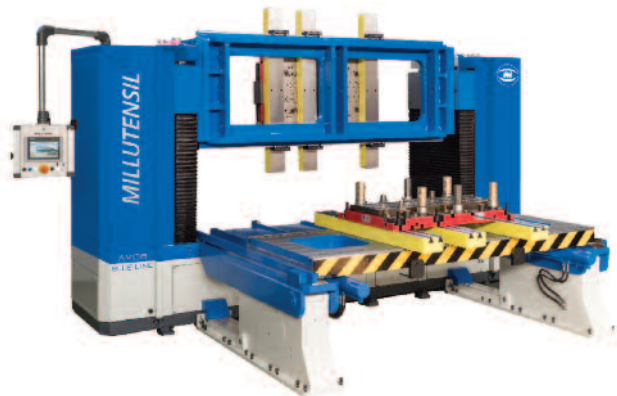

Tilting

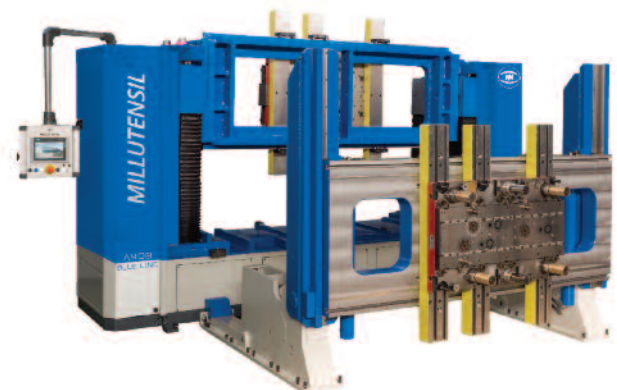



# INDEX

AM04  
AM06  
AM08  
AM09  
A01

- A01-8 Descrizione piano superiore
- A01-8 Beschreibung Obertisch
- A01-8 Upper platen description
- A01-8 Description plateau supérieur



AM04  
AM06  
AM08  
AM09  
A02

- A02-9 Descrizione piano inferiore
- A02-9 Beschreibung Untertisch
- A02-9 Lower platen description
- A02-9 Description plateau inférieur

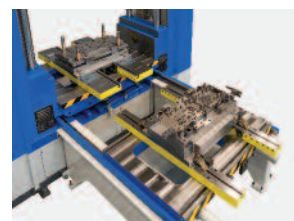

AM04  
AM06  
AM08  
AM09  
A03

- A03-10 Dimensioni
- A03-10 Abmessungen
- A03-10 Overall dimensions
- A03-10 Encombrement machine

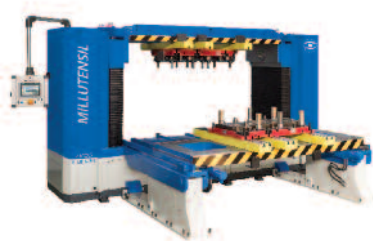

# TOUCH PANEL A04



- A04-11 Touch panel multipanel
- A04-11 Multi Touch Panel
- A04-11 Touch panel multipanel
- A04-11 Touch panel multipanel

# SOLUZIONE PER GRANDI STAMPI B01

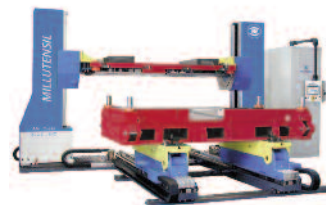

- B01-16 Soluzioni per grandi stampi
- B01-16 Lösungen für grosse Werkzeuge
- B01-16 Solutions for big dies
- B01-16 Solutions pour outils de grandes dimensions

# ACCESSORI A05



- A05-12/13 Accessori
- A05-12/13 Zubehör
- A05-12/13 Accessories
- A05-12/13 Accessoires

# AM1530 AM3040 AM5045 B02



- B02-17 Dati tecnici
- B02-17 Technische Daten
- B02-17 Technical data
- B02-17 Données techniques

# AM04 AM06 AM08 AM09 A06



- A06-14 Dati tecnici
- A06-14 Technische Daten
- A06-14 Technical data
- A06-14 Données techniques

# AM1530 AM3040 AM5045 B03-B04

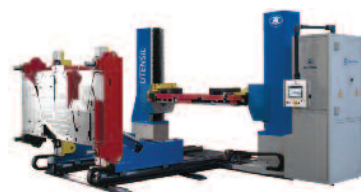

- B03-18 Descrizione piano superiore
- B03-18 Beschreibung Obertisch
- B03-18 Upper platen description
- B03-18 Description plateau supérieur
- B04-19 Descrizione piano inferiore
- B04-19 Beschreibung Untertisch
- B04-19 Lower platen description
- B04-19 Description plateau inférieur

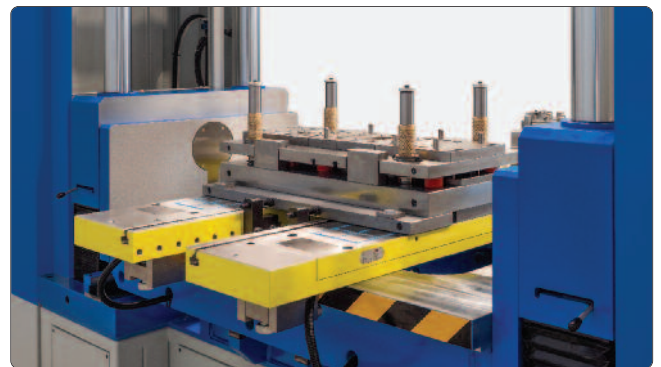
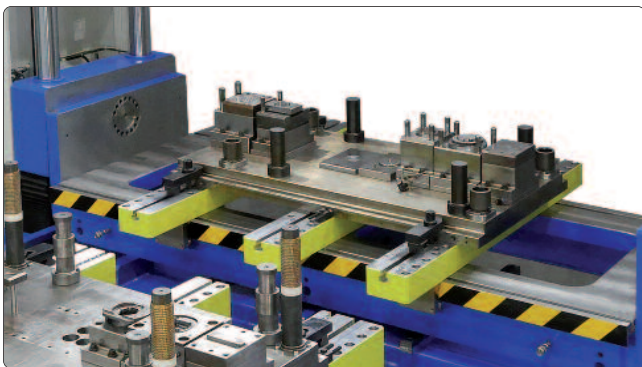

**I**

Per montaggio, aggiustaggio, controllo e riparazione degli stampi di trancitura, ecc.

**I**

**PIANO SUPERIORE**

Il piano superiore è scorrevole verticalmente, con azionamento idraulico su quattro colonne di guida ed è girevole di 360° mediante motoriduttori, per portare la parte superiore dello stampo in posizione comoda per il lavoro. Il bloccaggio del piano superiore, nella esatta posizione orizzontale, è dato da quattro spine di posizionamento azionate idraulicamente.

**EN**

**UPPER PLATEN**

The upper platen slides vertically by hydraulic actuation on the four guide columns and can be tilted by 360° through reduction gears. In this way, it is possible to place the upper part of the die in an effortless working position. The upper platen clamping in the exact horizontal position depends on the four hydraulically actuated locating pegs.

**D**

Zur Montage, Justierung, Prüfung und Reparatur der Werkzeuge wie z.B. Stanzwerkzeuge usw.

**D**

**OBERTISCH**

Durch eine hydraulische Betätigung gleitet der Obertisch senkrecht an den vier Führungssäulen entlang und durch Untersetzungsgetriebe ist er um 360° drehbar. Dadurch ist es möglich das Werkzeugoberteil zur Ausführung der Bearbeitungen in eine bequeme Arbeitsstellung zu bringen. Die Blockierung des Obertisches in seiner genauen horizontalen Stellung ergibt sich durch vier hydraulisch betätigte Passtifte.

**F**

**PLATEAU SUPERIEUR**

Le plateau supérieur se déplace verticalement par commande hydraulique sur 4 colonnes et peut tourner de 360°, actionné par des motoréducteurs, pour présenter l'outillage dans la meilleure position. Le verrouillage du plateau supérieur dans l'exacte position horizontale est assuré par 4 goupilles de précision commandées hydrauliquement.

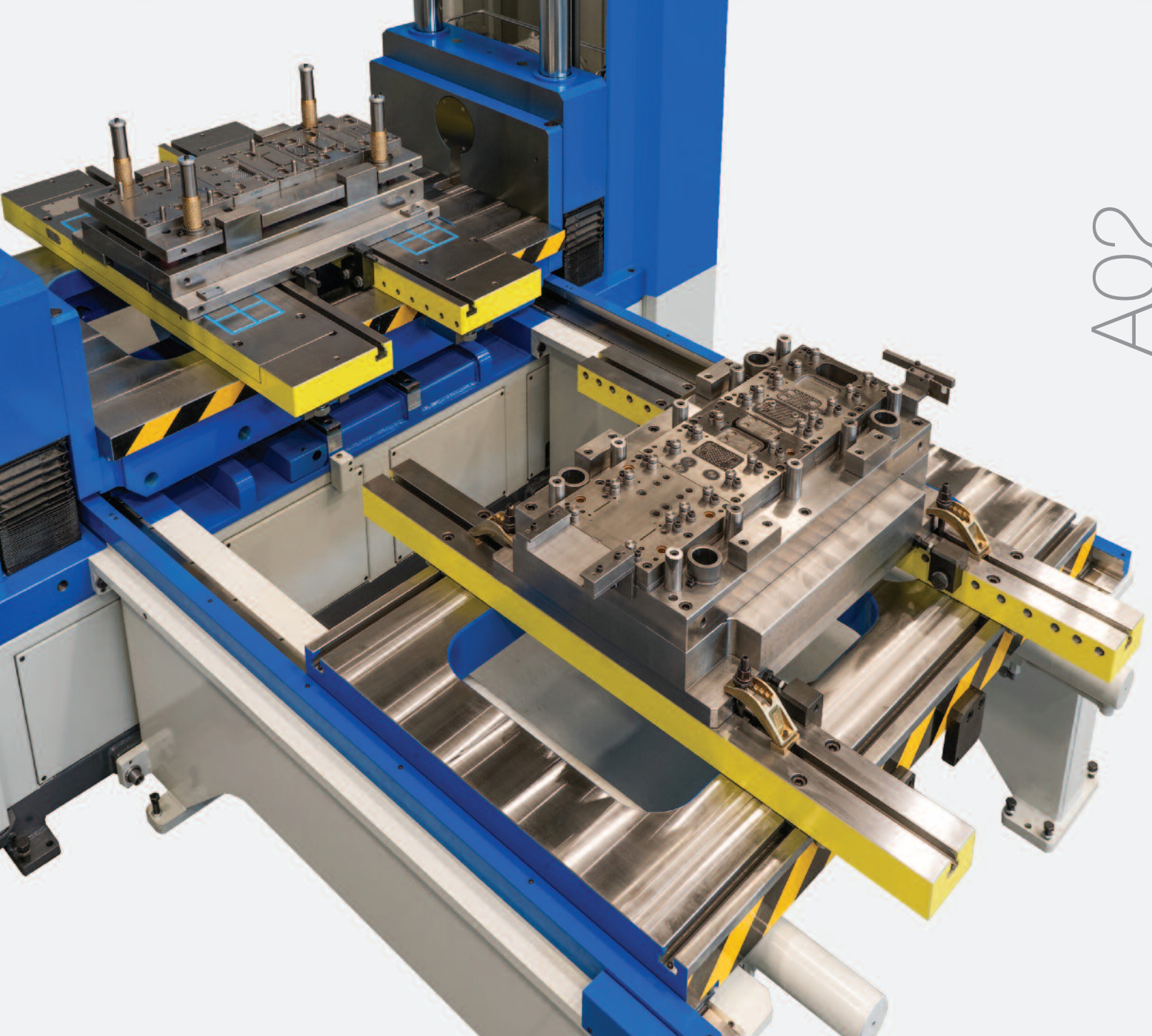

**EN**

For splitting, adjusting, maintenance and try-out operations on dies etc.

**I****PIANO INFERIORE**

Il piano inferiore è estraibile e scorre sul piano base, guidato da cuscinetti a sfere, mediante azionamento idraulico.

Esso consente di portare la parte inferiore dello stampo esternamente e posteriormente all'apristampo e girato di 90° per permettere di accedere ad ogni parte del semistampo.

**EN****LOWER PLATEN**

The lower platen is extensible and slides on the base plate, guided by ball bearings, through hydraulic drive.

It allows to bring the lower part of the die outwards and backwards and to turn it by 90° to allow access to every part of the half die.

**F**

Pour le démontage, la maintenance et le remontage des outils, etc.

**D****UNTERTISCH**

Der ausziehbare, von Kugellagern geführte Untertisch gleitet mittels hydraulischem Antrieb auf dem Grundtisch.

Er ermöglicht den unteren Teil des Werkzeugs nach aussen und rückseitig des Werkzeugöffners hin zu bringen und um 90° zu drehen, um den Zugang zu jedem Teil der Werkzeughälfte zu ermöglichen.

**F****PLATEAU INFÉRIEUR**

Le plateau inférieur monté sur patins à billes coulisse sur le bâti. Ce mouvement est réalisé par un vérin hydraulique. Il peut transporter le demi-outil inférieur à l'extérieur et à l'arrière du banc, il peut être tourné à 90° pour permettre l'accès à chaque élément du bloc.

A03

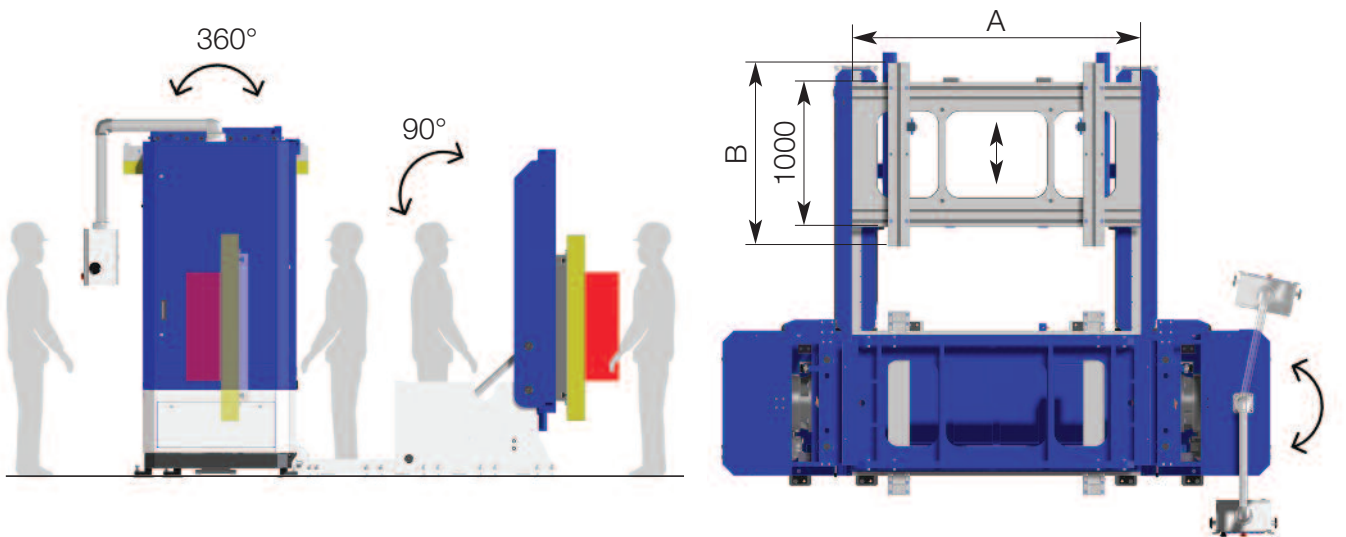
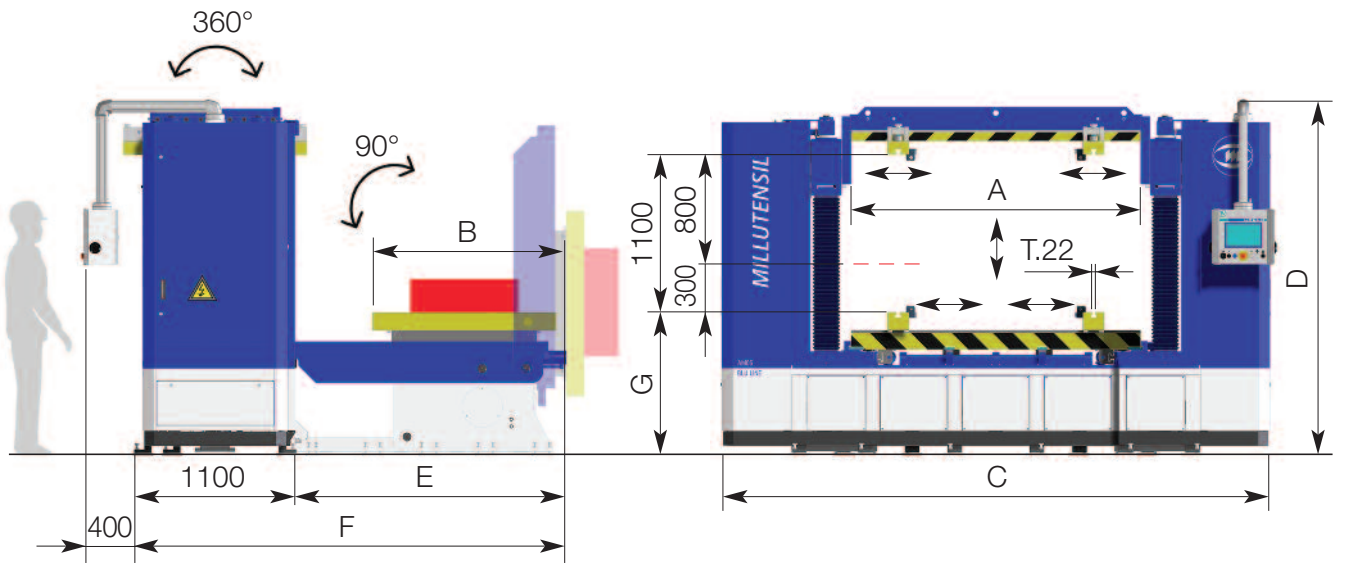

MODEL	A x B	C	D	E	F	G
AM 04	1400 x 1070	2900	2450	1500	2600	920
AM 06	2000 x 1270	3800	2450	1900	3000	960
AM 08	2600 x 1470	4400	2450	1900	3000	960
AM 09	3000 x 1470	4800	2450	1900	3000	960

# TOUCH PANEL MULTIPANEL TP 900

- I** IL PLC ELETTRONICO “SIEMENS S7-1500” GESTISCE TUTTE LE FUNZIONI
- D** DER ELEKTRONISCHE PLC “SIEMENS S7-1500” VERWALTET ALLE FUNKTIONEN
- EN** THE “SIEMENS S7-1500” ELECTRONIC PLC HANDLES ALL THE FUNCTIONS
- F** LE PLC ELECTRONIQUE “SIEMENS S7-1500” COMMANDE TOUTES LES FONCTIONS





# ACCESSORIES

A05



- I** FLESSIBILITÀ DI STAFFAGGIO PER LE VARIE TIPOLOGIE DI STAMPI
- D** FLEXIBLE ANORDNUNG DER SPANNSYSTEME FÜR DIE UNTERSCHIEDLICHSTEN WERKZEUGSYSTEME
- EN** CLAMPING FLEXIBILITY FOR VARIOUS TYPES OF DIES
- F** FLEXIBILITE DE BRIDAGE SELON LES DIFFERENTS TYPES D'OUTILS

- I** TRAVERSE MOBILI PORTA STAMPO SPECIALI IN FUNZIONE DI SPECIFICHE ESIGENZE  
Forniamo traverse porta stampo speciali studiate in base alle diverse tipologie di stampo.
- D** FLEXIBLE SPANNSYSTEME FÜR INDIVIDUELLE KUNDENBEDÜRFNISSE UND ALLE WERKZEUGARTEN  
Wir liefern Spezialwerkzeugbefestigungstraversen für unterschiedliche Werkzeugtypologien entwickelt.
- EN** SPECIAL DIE HOLDING MOVABLE BEAMS FOR SPECIFIC NEEDS  
We supply special die holding beams for different dies typologies.

- F** CONSOLES PORTE-OUTIL TYPE PORTIQUE SELON EXIGENCES SPECIFIQUES  
Nous fournissons les supports d'outils type portique spécialement étudiés selon les différents types d'outillages.

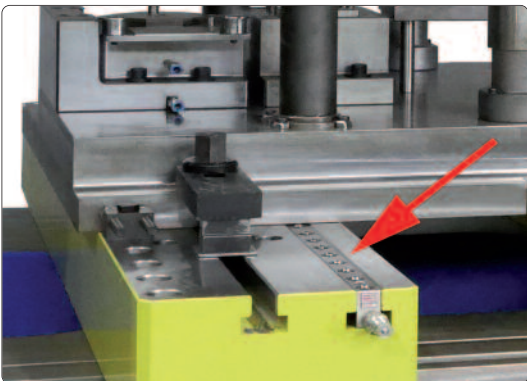

- I** FACILE MOVIMENTAZIONE DEL SEMISTAMPO INFERIORE
- D** EINFACHE BEWEGUNG DER UNTEREN WERKZEUGHÄLFTE
- EN** LOWER HALF DIE EASY HANDLING
- F** MANUTENTION FACILE DE LA PARTIE INFÉRIEURE DE L'OUTIL

- I** BARRE PORTA STAMPO CON INSERTI IDRAULICI A SFERE ROTOBILLE  
Facilitano la centratura manuale e l'accoppiamento dei due semistampi dopo eventuali smontaggi.
- D** WERKZEUGHALTEBALKEN MIT HYDRAULISCHEN ROTOBILLE KUGELEINSÄTZEN  
Diese erleichtern die manuelle Zentrierung und Verkopplung der zwei Werkzeughälften nach eventuellem Ausbau.
- EN** DIE HOLDING BEAMS WITH ROTOBILLE BALL HYDRAULIC INSERTS  
They facilitate manual centering and coupling of the two half dies after possible disassembly.
- F** CONSOLES PORTE-OUTIL AVEC INSERTS HYDRAULIQUES TYPE ROTOBILLE  
Elles facilitent le centrage manuel et le positionnement des deux parties de l'outil après démontage éventuel.

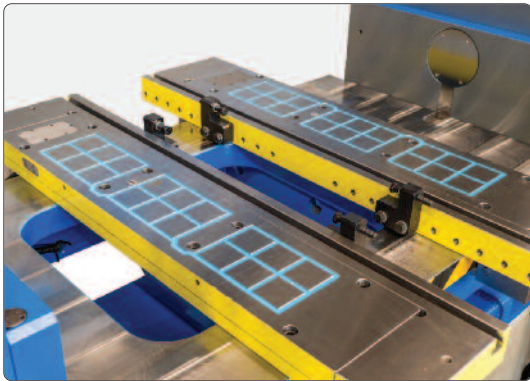

- I** VELOCE, PRATICO, FACILE FISSAGGIO DEGLI STAMPI
- D** SCHNELL, PRAKTISCH, EINFACHE BEFESTIGUNG DER WERKZEUGE
- EN** FAST, PRACTICAL AND EASY DIE CLAMPING
- F** RAPIDE, PRATIQUE, FIXAGE FACILE D'OUTILS

**I** PIANI DELLA MACCHINA CON MAGNETI PERMANENTI  
Permettono un rapido staffaggio dello stampo, disponibili in funzione dei modelli e delle portate.

**D** WERKZEUGAUFLAGETISCHE MIT PERMANENT MAGNETEN

Diese erlauben eine schnelle Montage der Werkzeuge, erhältlich auf der Basis der Maschinengröße und der Gewichte.

**EN** MACHINE PLATENS WITH PERMANENT MAGNETS  
For fast die clamping. Available according to model and capacity.

**F** PLATEAUX DE LA MACHINE AVEC AIMANTS PERMANENTS

Ils permettent une fixation rapide de l'outil, disponibles selon les modèles et les charges.

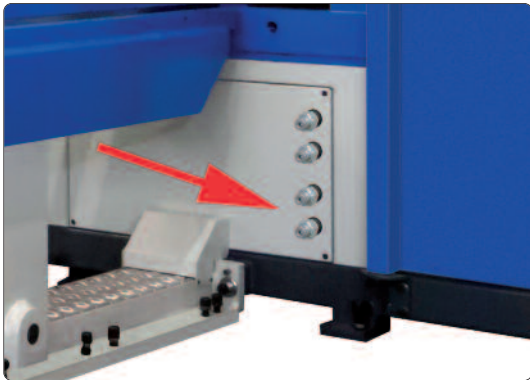

- I** FACILE GESTIONE E COLLAUDO DELLE SLITTE IDRAULICHE
- D** EINFACHE VERWALTUNG UND ÜBERPRÜFUNG DER HYDRAULISCHEN SCHLITTEN
- EN** SIMPLE HANDLING AND TESTING OF THE HYDRAULIC SLIDES
- F** GESTION FACILE ET ESSAI DES ROTOBILLES HYDRAULIQUES

**I** UNITÀ DI COMANDO CILINDRI AUSILIARI

Questo dispositivo idraulico consente di azionare eventuali cilindri applicati allo stampo per comando parti mobili (max. 2+2).

**D** ANTRIEBSEINHEIT DER KERNZÜGE IN DEM WERKZEUG

Diese hydraulische Vorrichtung dient zum Antrieb eventueller in dem Werkzeug angebrachten Zylinder zur Kontrolle der beweglichen Teile (max. 2+2).

**EN** CONTROL UNIT OF AUXILIARY CYLINDERS IN THE DIE

This hydraulic device allows movement of possible cylinders applied on the die for greater control of mobile parts (max. 2+2).

**F** UNITE DE COMMANDE VERINS DANS LE MOULE

Ce dispositif hydraulique permet d'actionner les vérins fixés dans le moule, afin de manœuvrer les parties mobiles (maxi. 2+2).



# TECHNICAL DATA

A06

MODEL		AM 04	AM 06	AM 08	AM 09
Forza max. chiusura Max. Schliesskraft Max. clamping force Force maxi. de fermeture	kN	60	120	150	160
Pressione max. esercizio Max. Arbeitsdruck Max. working pressure Pression maxi. de service	bar	200	200	200	200
Dimensione dei piani Tischaufspannfläche Platens dimension Dimensions des plateaux	mm	1400 x 1070	2000 x 1270	2600 x 1470	3000 x 1470
Apertura min. tra i piani Einbauhöhe min. Min. opening between platens Ouverture mini. entre les plateaux	mm	300	300	300	300
Apertura max. tra i piani Einbauhöhe max. Max. opening between platens Ouverture maxi. entre les plateaux	mm	1100	1100	1100	1100
Peso max. sul piano inferiore Max. Belastbarkeit auf unterem Tisch Max. load capacity on lower platen Poids maxi. sur le plateau inférieur	kg	4000	6000	8000	9000
Peso max. per rotazione piano superiore Max. Gewicht zur Drehung des Obertisches Max load capacity on rotating upper platen Poids maxi. pour la rotation du plateau sup.	kg	1500	3000	3500	4000
Velocità di avvicinamento Annäherungsgeschwindigkeit Approaching speed Vitesse d'approche	mm/s	20	20	20	20
Velocità di lavoro Arbeitsgeschwindigkeit Working speed Vitesse de travail	mm/s	6	6	6	6
Velocità di ritorno Rücklaufgeschwindigkeit Reversing speed Vitesse de retour	mm/s	15	15	15	15
Potenza motore principale Hauptmotorleistung Power of main engine Puissance du moteur principal	Kw	4	4	4	4
Peso totale Maschinengewicht Machine weight Poids total	kg	7500	11200	12800	13500
COLORE: GRIGIO RAL 7035 FARBE: GRAU RAL 7035 COLOUR: GREY RAL 7035 COULEUR: GRIS RAL 7035	Parti mobili: BLU RAL 5017 Bewegliche Teile: BLUE RAL 5017 Movable parts: BLUE RAL 5017 Parties mobiles: BLEU RAL 5017				





Working together  
for your safety



## I SOLUZIONI PER GRANDI STAMPI

Movimento di salita e discesa tramite viti a ricircolo di sfere azionate da motori brushless. Controllo del parallelismo tramite encoder. Gestione con PLC Siemens e comandi tramite touch panel.

## D LÖSUNGEN FÜR GROSSE WERKZEUGE

Auf- und Abwärtsbewegung mittels Kugelumlaufspindeln von Servomotoren angetrieben. Überwachung der Parallelität durch Encoder-Messräder. Steuerung mit Siemens SPS und Befehle über Touch-Panel.

## EN SOLUTIONS FOR BIG DIES

Up and down movement by recirculating ball screws activated by brushless motors. Parallelism control through encoders. Monitored through Siemens PLC commanded by Touch Panel.

## F SOLUTIONS POUR OUTILS DE GRANDES DIMENSIONS

Déplacement de Monte et Baisse par vis à billes entraînées par moteur CC. Contrôle du parallélisme par codeurs. Gestion avec PLC Siemens et commandes par touches tactiles au tableau.

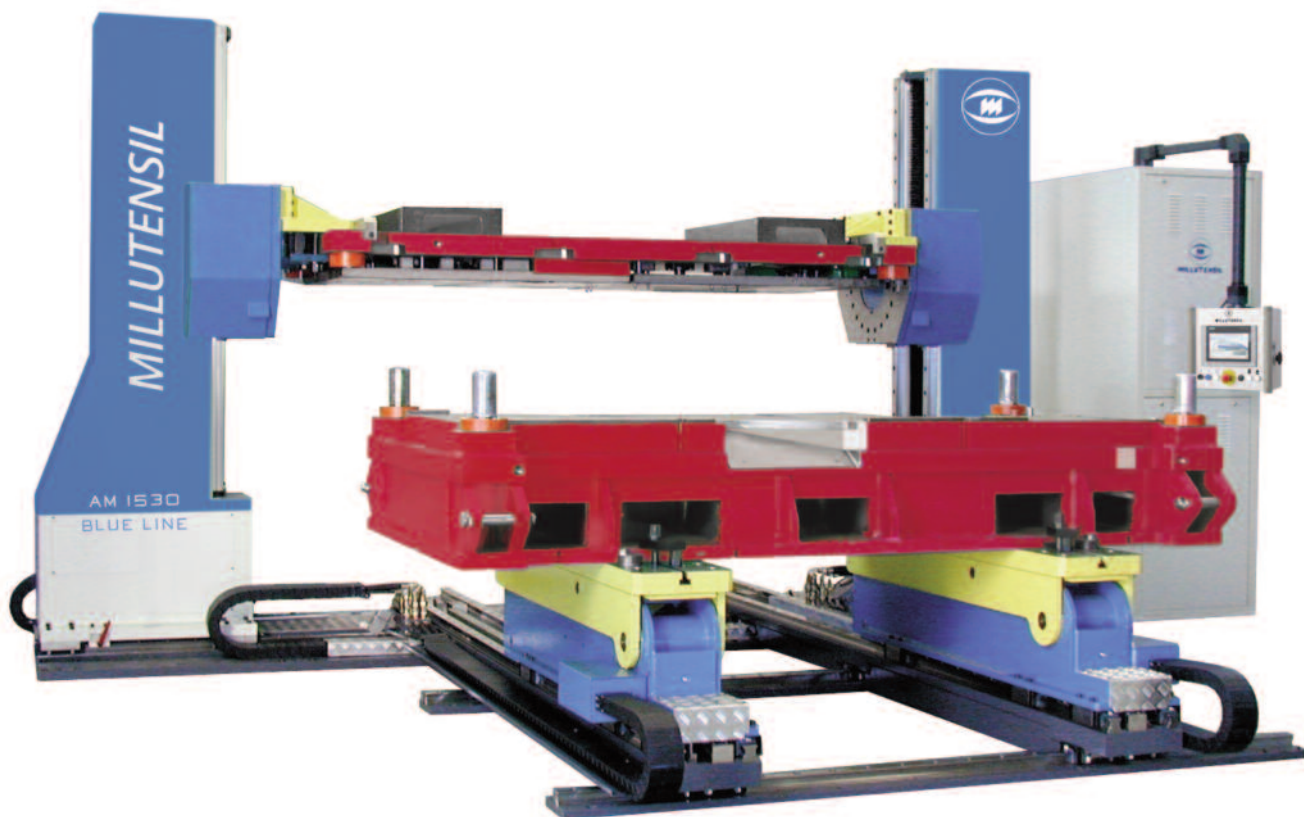

# TECHNICAL DATA

BO2

MODEL		AM 1530	AM 3040	AM 5045
Dimensione dei piani Tischauflspannfläche Platens dimension Dimensions des plateaux	mm	3000 x 1700	4000 x 2000	4500 x 2800
Apertura min. tra i piani Einbauhöhe min. Min. opening between platens Ouverture mini. entre les plateaux	mm	320	500	500
Apertura max. tra i piani Einbauhöhe max. Max. opening between platens Ouverture maxi. entre les plateaux	mm	1450	2100	2200
Peso max. sul piano inferiore Max. Belastbarkeit auf unterem Tisch Max. load capacity on lower platen Poids maxi. sur le plateau inférieur	kg	15000	30000	50000
Peso max. per rotazione piano superiore Max. Gewicht zur Drehung des Obertisches Max. load capacity on rotating upper platen Poids maxi. pour la rotation du plateau sup.	kg	7000	13000	20000

Fast splitting = Time saving



■ PIANO SUPERIORE ■ OBERTISCH ■ UPPER PLATE ■ PLATEAU SUPÉRIEUR

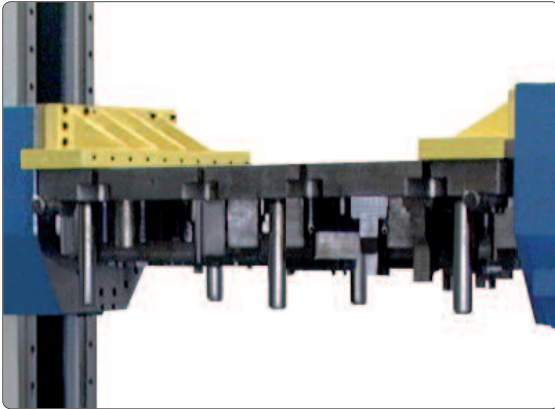

**I**

Versione con un montante verticale fisso e uno mobile per adattarsi alla larghezza stampo, con staffe indipendenti, ruotabili di 180°, per fissaggio dello stampo ai due lati.

**D**

Ausführung mit einem feststehenden, vertikalen und einem beweglichen Ständer, zur Einstellung auf die richtige Werkzeugbreite. An den Drehlagern werden die Werkzeuge befestigt und können um 180° gedreht werden.

**EN**

Version with one fixed and one movable vertical rod to adapt to the die width, with independent brackets that can be rotated 180° to clamp the die on both sides.

**F**

Version avec un montant vertical fixe et un mobile pour adaptation à la largeur des outils, avec bridage indépendant, pivotants de 180° pour la fixation des outils des deux côtés.

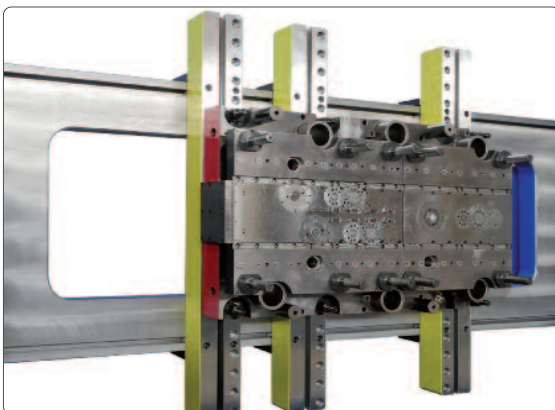

**I**

Versione a montanti verticali fissi con piano mobile superiore, ruotabile di 180°, provvisto di traverse mobili per staffaggio stampo regolabili in larghezza.

**D**

Ausführung mit zwei feststehenden vertikalen Ständern und einem beweglichen Obertisch, um 180° drehbar, mit zwei beweglichen Traversen zur Befestigung der Werkzeuge in der Breite anpassbar.

**EN**

Version with fixed vertical rods and with upper movable platen, that can be rotated 180°, equipped with die clamping movable beams that can be adjusted in their width.

**F**

Version à montants verticaux fixes avec niveau supérieur mobile, pivotant de 180° pourvus de traverses mobiles pour le bridage d'outils réglables en largeur.

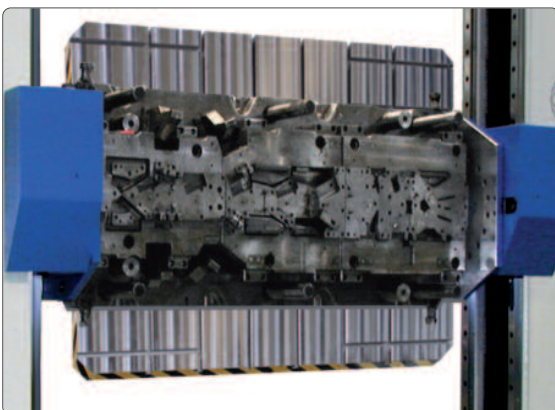

**I**

Versione a montanti verticali fissi con piano mobile superiore, ruotabile di 180°, provvisto di cave a T per fissaggio stampo.

**D**

Ausführung mit zwei feststehenden vertikalen Ständern und einem beweglichen Obertisch, um 180° drehbar, mit T-Nuten versehen zur Befestigung der Werkzeuge.

**EN**

Version with fixed vertical rods and with movable upper platen, that can be rotated 180°, equipped with T-slots for die clamping.

**F**

Version à montants verticaux fixes avec étage supérieur mobile, pivotant de 180° avec rainures en T pour la fixation des outils.



■ PIANO INFERIORE ■ UNTERTISCH ■ LOWER PLATE ■ PLATEAU INFERIEUR

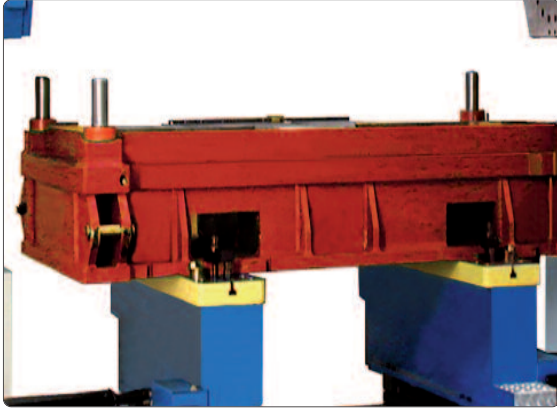

**I**

Versione con due carri estraibili indipendenti adattabili alla larghezza stampo. Per alcune versioni e limitatamente alla portata e' disponibile il ribaltamento a 90°.

**D**

Ausführung mit 2 unabhängigen ausfahrbaren Schritten, auf die Breite des Werkzeuges einstellbar. Für gewisse Versionen und gewichtsabhängig auch mit 90° Kippvorrichtung erhältlich.

**EN**

Version with two independent extensible shuttles that can be adjusted to the die width. 90° tilt is available for some versions and depending on capacity.

**F**

Version avec deux chariots indépendants extensibles pour adaptation à la largeur des outils. Basculement à 90° disponible pour certaines versions selon la capacité.

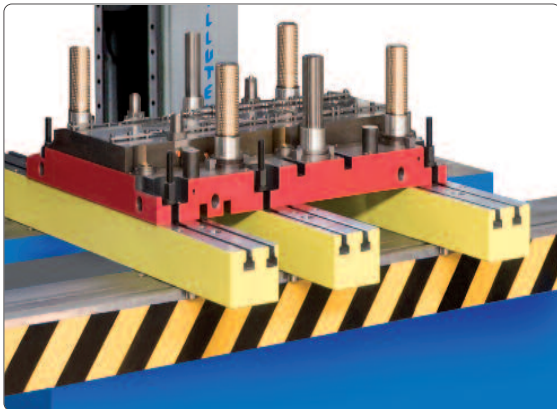

**I**

Versione con carro estraibile provvisto di traverse mobili per staffaggio stampo regolabili in larghezza.

**D**

Ausführung mit ausfahrbarem Wagen und einstellbaren Traversen. Einstellung der jeweiligen Werkzeugbreite und Festspannung des Werkzeuges.

**EN**

Version with extensible shuttle equipped with movable beams for die clamping that can be adjusted in their width.

**F**

Version avec plateau sortant pourvu de traverses mobiles pour le fixage des outils, réglables en largeur.



**I**

Versione con carro estraibile composto da un piano provvisto di cave a T per fissaggio stampo.

**D**

Ausführung mit ausfahrbarem tischwagen mit T-Nuten zur Festspannung des Werkzeuges.

**EN**

Version with extensible shuttle made up of a platen equipped with T-slots for mould clamping.

**F**

Version avec plateau sortant composé d'un étage avec rainures en T pour la fixation des outils.

# DIE-SPLITTERS

- APRISTAMPI BLUE LINE
- WERKZEUGÖFFNER BLUE LINE
- BLUE LINE DIE-SPLITTERS
- BANC D'OUVERTURE DES OUTILS BLUE LINE

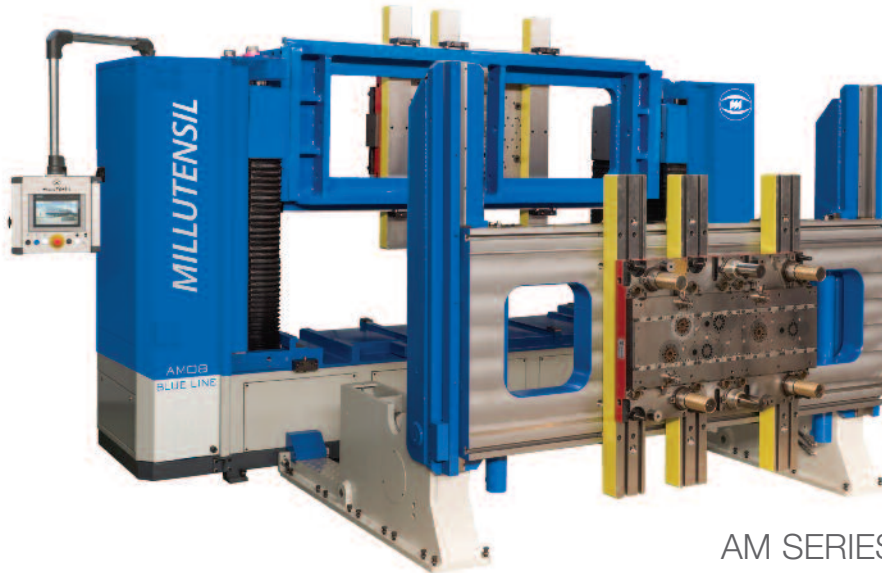

AM SERIES

MODEL	PLATENS DIMENSION (MM) - (INCH)	MAX LOAD CAPACITY (KG)
AM 04	1400 x 1070 - 55 x 42	4000
AM 06	2000 x 1270 - 78 x 50	6000
AM 08	2600 x 1470 - 102 x 58	8000
AM 09	3000 x 1470 - 118 x 58	9000



AM SERIES

MODEL	MAX DIE SIZE (MM) - (INCH)	MAX LOAD CAPACITY (KG)
AM 1530	3000 x 1700 - 118 x 67	15000
AM 3040	4000 x 2000 - 157 x 78	30000
AM 5045	4500 x 2800 - 177 x 110	50000

# SPOTTING PRESSES

- PRESSE PROVA STAMPI BLUE LINE
- TUSCHIERPRESSEN BLUE LINE
- BLUE LINE DIE & MOULD SPOTTING PRESSES
- PRESSES D'ESSAI DE MOULES BLUE LINE



## MIL CLASSIC SERIES

MODEL	PLATENS DIMENSION (MM) - (INCH)	CLAMPING FORCE (TON)
MIL 122-123	1200 x 1000 - 47 x 39	60-80
MIL 142-143	1400 x 1200 - 55 x 47	70-100
MIL 162-163	1600 x 1300 - 63 x 51	100-150
MIL 202-203	2000 x 1500 - 78 x 59	120-150
MIL 252-253	2500 x 1700 - 98 x 67	150-200
MIL 262-263	2500 x 2000 - 98 x 78	150-200
MIL 302-303-304	3000 x 2000 - 118 x 78	250-300-400
MIL 305	3000 x 2400 - 118 x 94	400 - 500
MIL 306	3500 x 2400 - 138 x 94	400 - 500
MIL 307	3500 x 2500 - 138 x 98	400 - 500
MIL 408	4000 x 2500 - 157 x 98	400 - 500



## MIL COMPACT SERIES

MODEL	PLATENS DIMENSION (MM) - (INCH)	CLAMPING FORCE (TON)
MIL 2015	2000 x 1500 - 78 x 59	120 - 150
MIL 2520	2500 x 2000 - 98 x 78	150 - 200
MIL 3020	3000 x 2000 - 118 x 78	250 - 300
MIL 3025	3000 x 2500 - 118 x 98	250 - 300
MIL 3525	3500 x 2500 - 138 x 98	300 - 400
MIL 3030	3000 x 3000 - 118 x 118	300 - 400
MIL 3530	3500 x 3000 - 138 x 118	300 - 400
MIL 4030	4000 x 3000 - 157 x 118	300 - 400



## BV SERIES

MODEL	PLATENS DIMENSION (MM) - (INCH)	CLAMPING FORCE (TON)
BV 25P	780 x 660 - 31 x 25	18
BV 26C	980 x 750 - 38 x 29	30
BV 26E	980 x 750 - 38 x 29	30
BV 26E-R	980 x 750 - 38 x 29	30
BV 28E	1200 x 1000 - 47 x 39	50
BV 28E-R	1200 x 1000 - 47 x 39	50
BV 28E-G	1200 x 1000 - 47 x 39	50
BV 28E-RG	1200 x 1000 - 47 x 39	50
BV 30E	1500 x 1000 - 59 x 39	50
BV 30E-R	1500 x 1000 - 59 x 39	50
BV 30E-G	1500 x 1000 - 59 x 39	50
BV 30E-RG	1500 x 1000 - 59 x 39	50

# YOUR SPOTTING AND SPLITTING SPECIALIST

LIMITED EDITION  
MIL SERIES

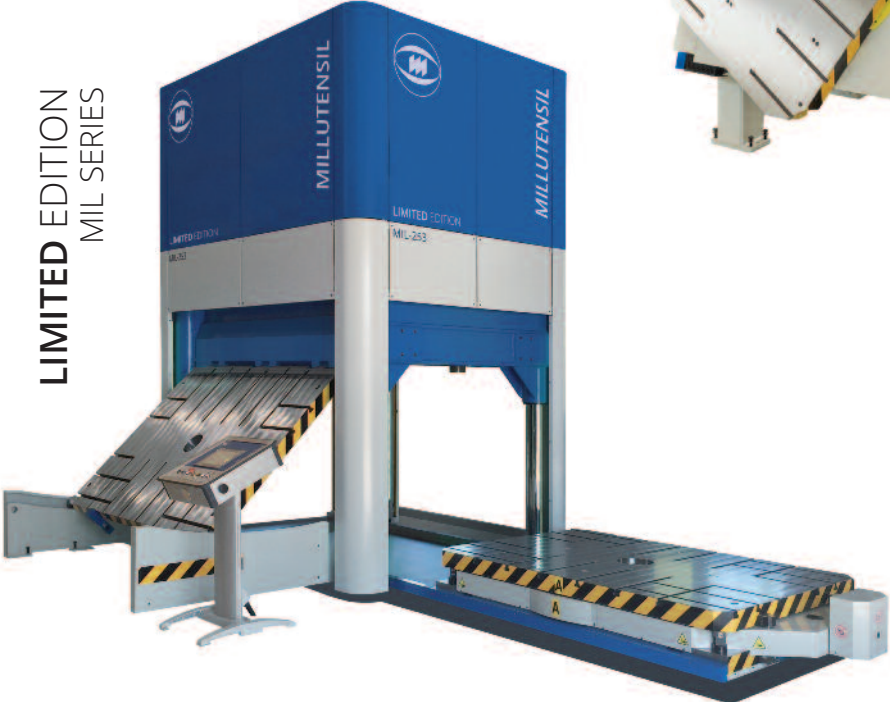

LIMITED EDITION  
BV SERIES



AM SERIES





BE SAFE. BE FAST.







**Office** Corso Buenos Aires, 92  
20124 Milano - Italia  
Tel. +39 02 29404390  
Fax +39 02 2046677

**Plant** Via delle Industrie, 10  
26010 Izano (CR) - Italia  
info@millutensil.com  
millutensil.com

