

Indoor KEENULDAH48AA
Outdoor KEENHYDHP48AA
Air Handler Heat Pump System

Location:	Approval:
Engineer:	Date:
Submitted to:	Construction:
Submitted by:	Unit #:
Reference:	Drawing #:

INDOOR SPECIFICATION

ESP (in WG)		0~0.8
Indoor Air Flow (Turbo/H/M/L/Si) (CFM)		1601.0 / 1442.1 / 1265.5 / 1088.9 / N/A
Indoor Noise Level (Turbo/H/M/L/Si) (dBA)		N/A / 53.0 / 49.5 / 33.5 / N/A
Dimension (W×D×H)	inch	21.50 x 21.50 x 55.94
	mm	546.0 x 546.0 x 1421
Package (W×D×H)	inch	59.84 x 25.00 x 31.10
	mm	1520 x 635 x 790
Net/Gross Weight	lbs	186.51 / 232.14
	kg	84.6 / 105.3

OUTDOOR SPECIFICATION

Compressor Type		ROTARY
Compressor Model		MTH550UKPC8FU
Refrigerant		R454B
Refrigerant Oil Charge (mL)		1800
Refrigerant Oil		HAF68D1C
Outdoor Air Flow (Max) (CFM)		3037.2
Outdoor Noise Level (dBA)		65
Dimension (W×D×H)	inch	38.58 x 16.34 x 38.39
	mm	980.0 x 415.0 x 975.0
Package (W×D×H)	inch	45.08 x 19.68 x 42.52
	mm	1145 x 500 x 1080
Net/Gross Weight	lbs	232.59 / 201.50
	kg	105.5 / 91.4

EFFICIENCY

Cooling		Heating	
SEER2	17.5	HSPF2-4	9.5
EER2	12.0	COP	3.28

PERFORMANCE of Cooling

Cooling (Btu/hr)	
Rated Capacity	48000
Min/Max Capacity	18000 ~ 52000
Moisture Removal (L/h)	4.94
Standard Operating Range (°F/°C)	-22 ~ 122 (-30 ~ 50)
Rated Cooling Conditions:	Indoor: 80°F DB / 67°F WB Outdoor: 95°F DB / 75°F WB

PERFORMANCE of Heating

Heating (Btu/hr)	
1. @ 47°F Rated	48000
2. @ 47°F Min/Max Capacity	13500 ~ 52000
3. @ 17°F Rated	34000
4. @ 5°F Rated: Capacity / COP	48000 / 2
5. @ 5°F Max: Capacity	48000
Standard Operating Range (°F/°C)	-22 ~ 75 (-30 ~ 24)
1. Rated Heating Conditions:	Indoor: 70°F DB / 60°F WB Outdoor: 47°F DB / 43°F WB
2. Rated Heating Conditions:	Indoor: 70°F DB / 60°F WB Outdoor: 17°F DB / 15°F WB
3. Heating Conditions, Compressor Operating at Max. Frequency	Indoor: 70°F DB / 60°F WB Outdoor: 5°F DB / 5°F WB

ELECTRICAL

Indoor Power Supply	115/208/230V, 60Hz, 1Ph
Indoor MCA 115V / (208/230V)	14.5 / 10
Indoor MOP	15
Outdoor Power Supply	208/230V, 60Hz, 1Ph
Outdoor MCA	38
Outdoor MOP	40
Communication Wiring	AWG 20-2
Compressor RLA	28
Outdoor Fan Motor RLA	2
Outdoor Fan Motor W	250
Indoor Fan Motor RLA	8
Indoor Fan Motor W	N/A
System Power Input @ Cooling (W)	4266 (1300 ~ 4870)
System Power Input @ Heating (W)	4521 (925 ~ 3880)
MCA: Min. circuit amps (A)	MOCP: Max. over current protection (A)
RLA: Rated load amps (A)	W: Fan motor rated output (W)

PIPING

Throttle type (Indoor)	EXV
Throttle type (Outdoor)	EXV
Liquid Size	9.52mm (3/8in)
Gas Size	19mm (3/4in)
Max. Piping Length (ft/m)	246 (75)
Max. Height Difference (ft/m)	98.4 (30)
Max. Pre-charged Length (ft/m)	24.6 (7.5)
Refrigerant Pre-charged Amount (oz/kg)	134.04 (3.8)
Additional Charge of Refrigerant ((oz/ft) / (g/m))	0.7 (65)
Connection Method	Flared

* When MOX630-48HFN10-M3X is paired with MVBDM-48HWFN10-WC3-D, an additional 0.65kg/22.93oz of refrigerant is required.

Indoor Unit Dimension

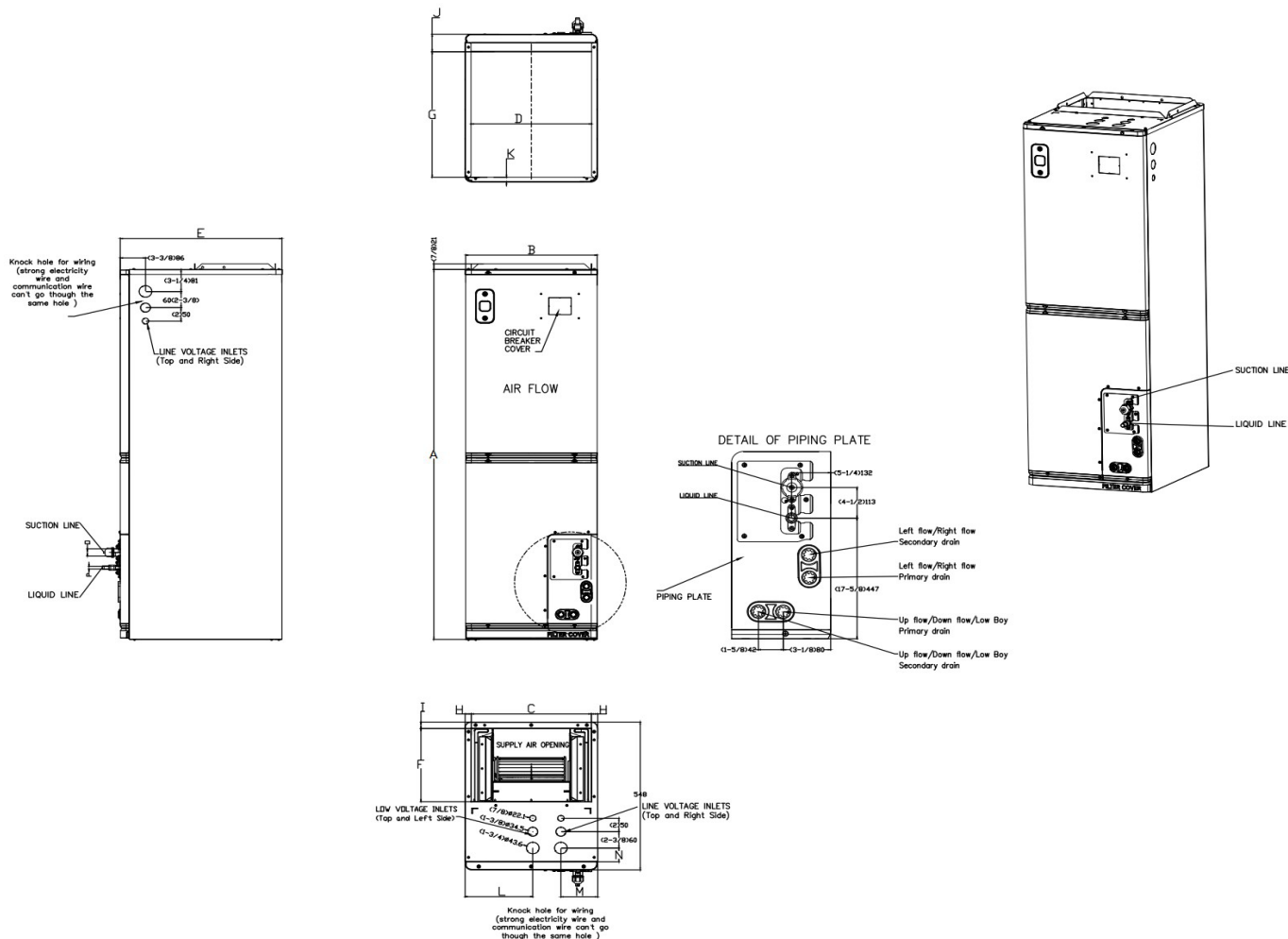

Dimensions		Model(Btu/h)		18K/24K		30K/36K		48K/54K	
		inch	mm	inch	mm	inch	mm		
A	Model Height	49-3/4	1263	54	1371	56	1421		
B	Model Width	14-1/2	368	17-1/2	445	21-1/2	546		
C	Supply Air Opening Width	12-7/8	328	16	405	19-7/8	506		
D	Return Air Opening Width	13	331	16	407	20	509		
E	Model Depth	21-1/2	546	21-1/2	546	21-1/2	546		
F	Supply Air Opening Depth	10-5/8	271	10-5/8	271	10-5/8	271		
G	Return Air Opening Depth	18-1/4	465	18-1/4	465	18-1/4	465		
H	Supply Air Opening Clearance	7/8	22	7/8	22	7/8	22		
I	Supply Air Opening Clearance	1	24	1	24	1	24		
J	Return Air Opening Front Clearance	2-1/2	65	2-1/2	65	2-1/2	65		
K	Return Air Opening Back Clearance	3/4	18	3/4	18	3/4	18		
L	Top cover knock hole	/	/	9	229	10-7/8	275		
M	Top cover knock hole	4-1/2	113	4-7/8	124	5-1/8	131		
N	Top cover knock hole	2	51	2	51	1-5/8	41		
O	Refrigerant piping flareconnection(gas)	3/4	19	3/4	19	3/4	19		
P	Refrigerant piping flareconnection(liquid)	3/8	9	3/8	9	3/8	9		

Outdoor Unit Dimension

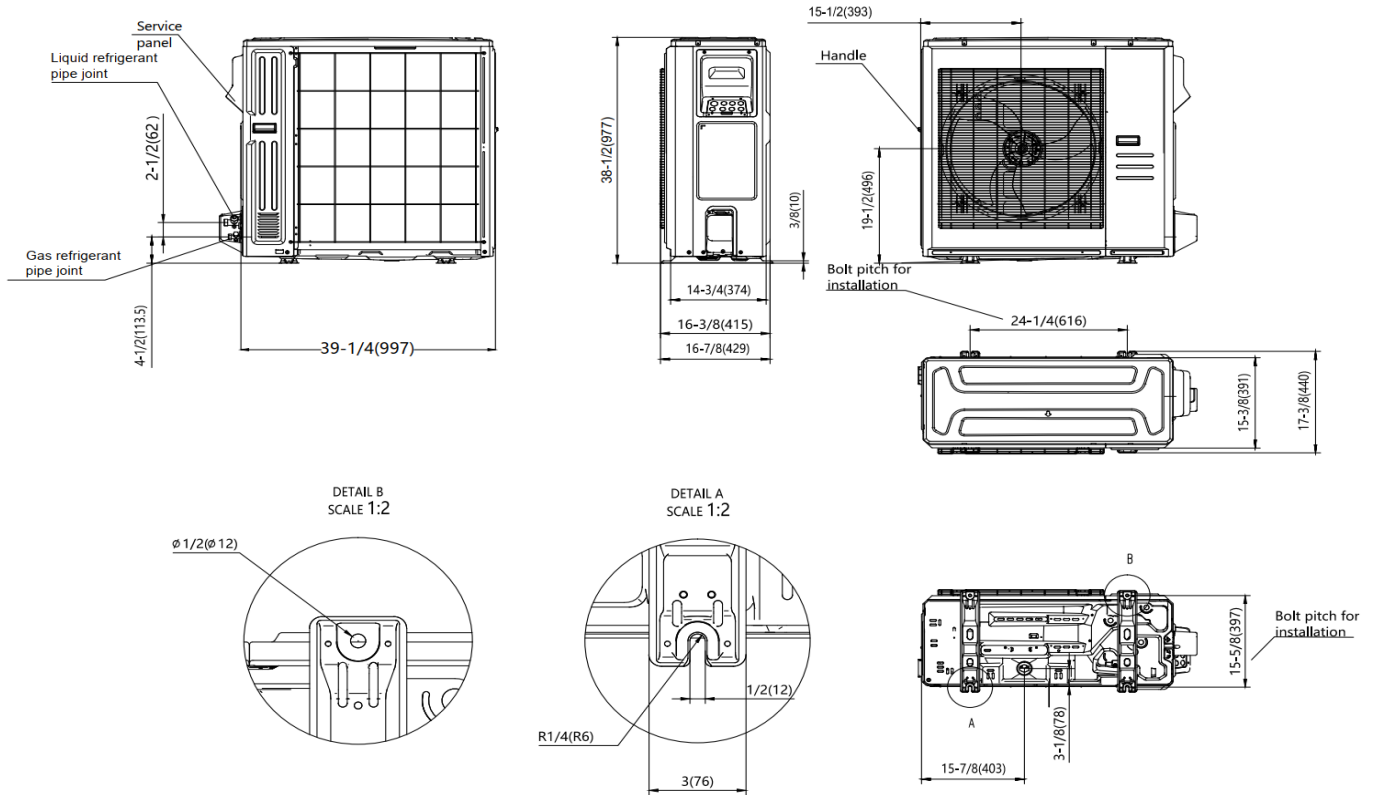

Installation Instruction For Outdoor Unit

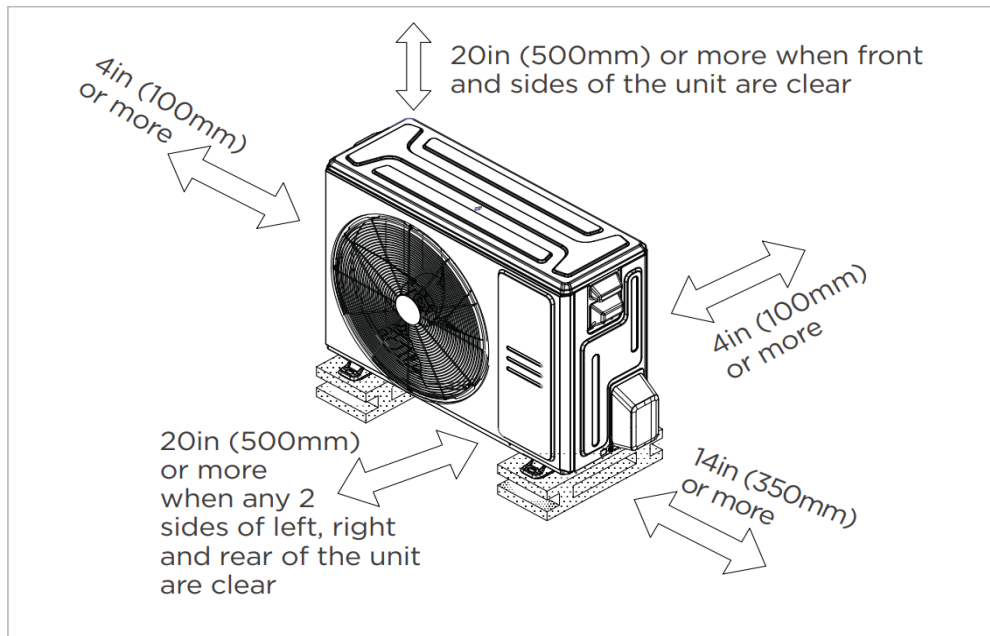

Meets all spatial requirements shown in Installation Clearance Requirements above.

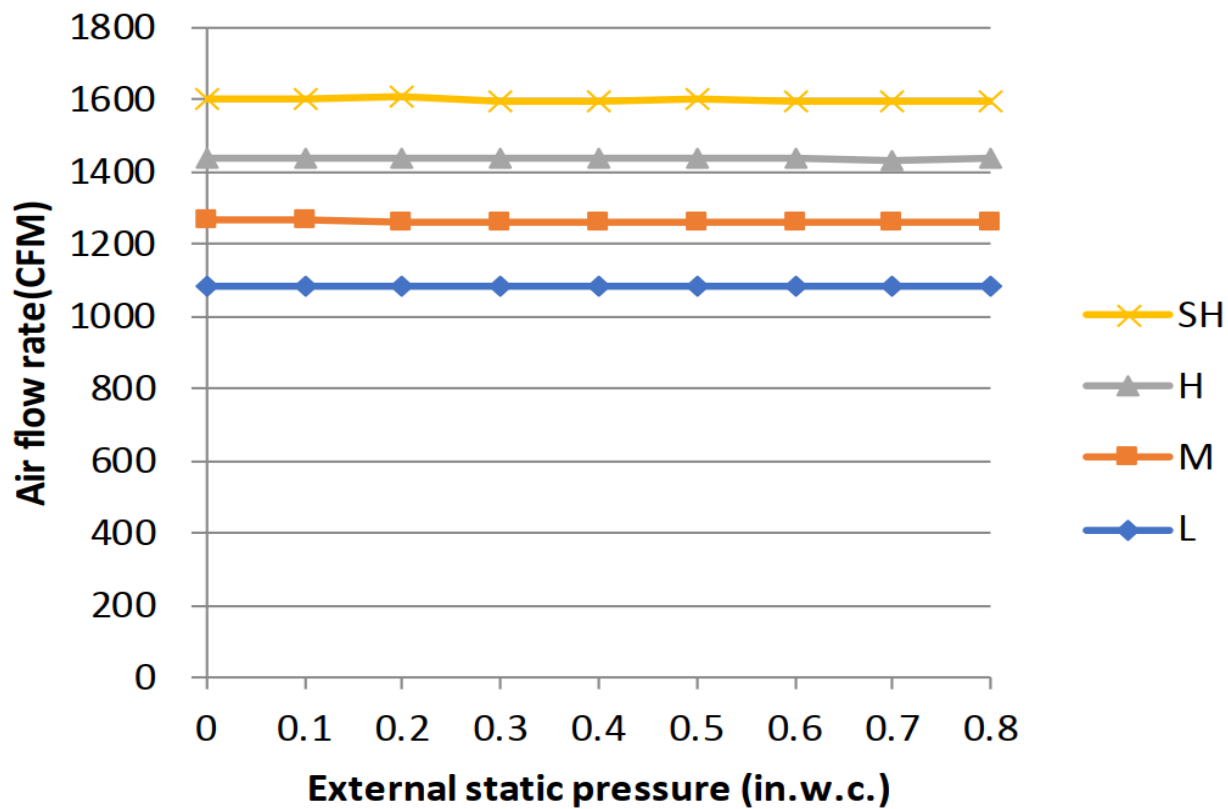

Features

- Multi-position installation: horizontal (left or right), vertical (up or down)
- 115/230V voltage compatible for IDU
- Aluminum Coil
- Constantly Air Flow system up to 1.0 In.W.G
- Optional Auxiliary heat kit up to 25kW
- Easy Maintenance
- Multiple control options available:
 - Two way communication wired controller:120N(X6)
 - Two way communication wired controller with built-in WiFi: 120N(X6W)
 - Wireless remote controller
 - Third-Party 24V Thermostat
- Adaptive Control System
- High efficiency up to 19 SEER2, 12.5 EER2, 10.8 HSPF2
- 100% heat output at -13F*
- Chassis heater and crankcase heater equipped as standard

* For MVBDM-36HWFN10-WB3-D pairing with MOX630-36HFN10-M3X, rated cooling capacity/heating capacity at -13F=100%