

**Indoor KEENSTPAH36AA**

**Outdoor KEENHYDHP36AA**

**Air Handler Heat Pump System**

Location:	Approval:
Engineer:	Date:
Submitted to:	Construction:
Submitted by:	Unit #:
Reference:	Drawing #:



INDOOR SPECIFICATION		
ESP (in WG)	0 - 0.8	
Indoor Air Flow (Turbo/H/M/L/Si) (CFM)	1,189 / 1,083 / 971 / 865 / 865	
Indoor Noise Level (Turbo/H/M/L/Si) (dBA)	59.5 / 59.5 / 57 / 48 / 48	
Dimension (WxDxH)	inch	62.13 x 23.33 x 10.93
	mm	1578 x 592.7 x 277.6
Package (WxDxH)	inch	66.14 x 26.77 x 13.58
	mm	1680 x 680 x 345
Net/Gross Weight	lbs	143.3 / 156.75
	kg	64.8 / 71.1

OUTDOOR SPECIFICATION		
Compressor Type	TWIN-ROTARY	
Compressor Model	EKPQ420D1UMUA	
Refrigerant	R454B	
Refrigerant Oil Charge (mL)	1460	
Refrigerant Oil	VG75	
Outdoor Air Flow (Max) (CFM)	3,002	
Outdoor Noise Level (dBA)	65	
Dimension (WxDxH)	inch	38.58 x 16.34 x 38.39
	mm	980 x 415 x 975
Package (WxDxH)	inch	45.08 x 19.68 x 42.52
	mm	1145 x 500 x 1080
Net/Gross Weight	lbs	204.15 / 235.23
	kg	92.6 / 106.7

EFFICIENCY			
Cooling		Heating	
SEER2	15.4	HSPF2-4	9.8
EER2	10.2	COP	3.30

PERFORMANCE of Cooling	
Cooling (Btu/hr)	
Rated Capacity	36,000
Min/Max Capacity	11,100 ~ 40,000
Moisture Removal (L/h)	3.26
Standard Operating Range (°F/°C)	-22 ~ 122 (-30 ~ 50)
Rated Cooling Conditions:	Indoor: 80°F DB / 67°F WB Outdoor: 95°F DB / 75°F WB

PERFORMANCE of Heating	
Heating (Btu/hr)	
1. @ 47°F Rated	37,000
1. @ 47°F Min/Max Capacity	10,700 ~ 45,000
2. @ 17°F Rated	31,200
3. @ 5°F Rated: Capacity / COP	36,000 / 1.9
3. @ 5°F Max: Capacity	36,000
Standard Operating Range (°F/°C)	-22 ~ 75 (-30 ~ 24)
1. Rated Heating Conditions:	Indoor: 70°F DB / 60°F WB Outdoor: 47°F DB / 43°F WB
2. Rated Heating Conditions:	Indoor: 70°F DB / 60°F WB Outdoor: 17°F DB / 15°F WB
3. Heating Conditions, Compressor Operating at Max. Frequency	Indoor: 70°F DB / 60°F WB Outdoor: 5°F DB / 5°F WB

ELECTRICAL	
Indoor Power Supply	115/208/230, 60Hz, 1Ph
Indoor MCA 115V / (208/230V)	115V:8A; 208/230V:6A
Indoor MOP	15
Outdoor Power Supply	208/230, 60Hz, 1Ph
Outdoor MCA	29
Outdoor MOP	30
Communication Wiring	AWG 20/2
Compressor RLA	20.5
Outdoor Fan Motor RLA	2.4
Outdoor Fan Motor W	250
Indoor Fan Motor RLA	115V:6.4A; 208/230V:4.5A
Indoor Fan Motor W	375
System Power Input @ Cooling (W)	3,529 (800 ~ 4,350)
System Power Input @ Heating (W)	3,286 (750 ~ 4,460)
MCA: Min. circuit amps (A)	MOCP: Max. over current protection (A)
RLA: Rated load amps (A)	W: Fan motor rated output (W)

PIPING	
Throttle Type (Indoor)	EXV
Throttle Type (Outdoor)	EXV
Liquid Size	9.52mm (3/8in)
Gas Size	19mm (3/4in)
Max. Piping Length (ft/m)	246 (75)
Max. Height Difference (ft/m)	98 (30)
Max. Pre-charged Length (ft/m)	24.6 (7.5)
Refrigerant Pre-charged Amount (oz/kg)	126.99 (3.6)
Additional Charge of Refrigerant ((oz/ft) / (g/m))	0.7 (65)
Connection Method	Flared

Indoor Unit Dimension

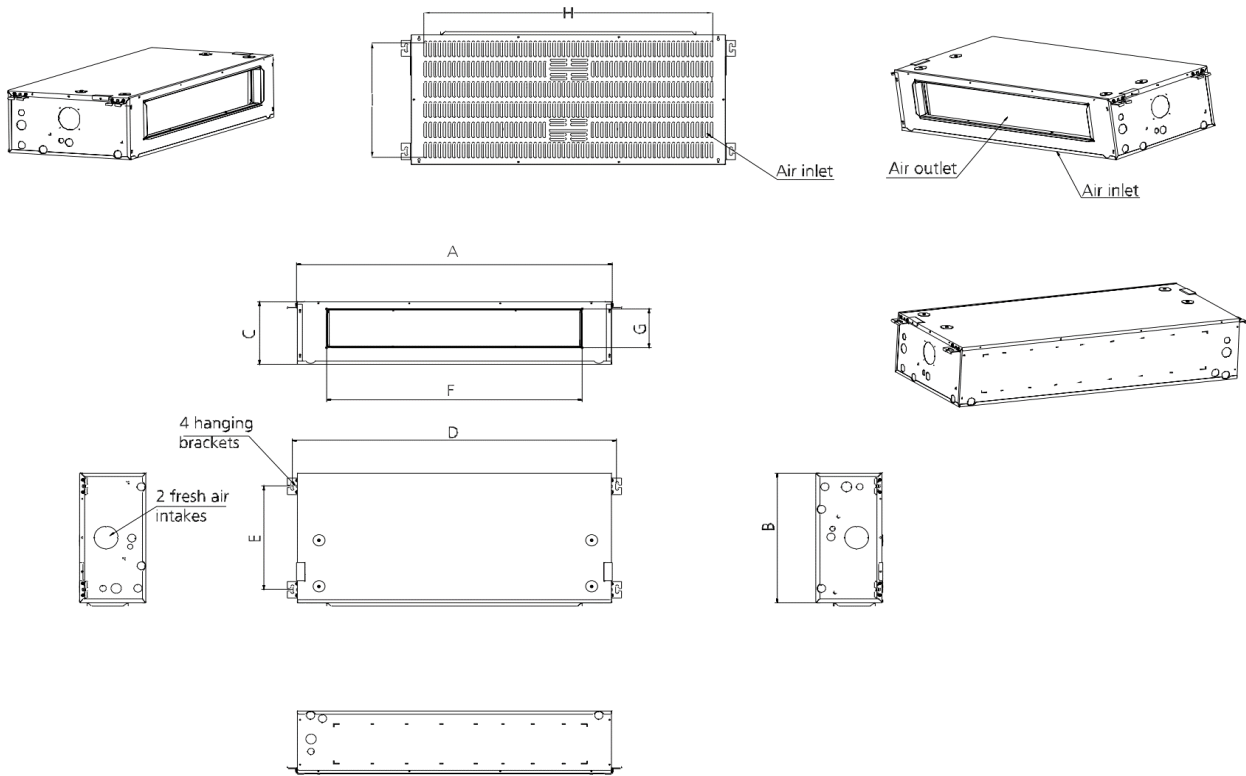

Dimensions		Model	18k	24k	30k/	36k
			inch(mm)	inch(mm)	inch(mm)	inch(mm)
Outline Dimension	A	Model Model	39-15/16 (1015)	45-7/8 (1165)	51-15/16 (1320)	58-7/8 (1495)
	B	Model Width	23-5/16 (593)	23-5/16 (593)	23-5/16 (593)	23-5/16 (593)
	C	Model Height	10-15/16 (278)	10-15/16 (278)	10-15/16 (278)	10-15/16 (278)
Size Of Mounted Lug	D	Mounted Lug Length	41-5/8 (1057)	47-1/2 (1207)	53-5/8 (1362)	60-1/2 (1537)
	E	Mounted Lug Width	18-1/8 (460)	18-1/8 (460)	18-1/8 (460)	18-1/8 (460)
Air Outlet Opening Size	F	Air Outlet Length	30-5/16 (769)	36-3/16 (919)	42-5/16 (1074)	49-3/16 (1249)
	G	Air Outlet Width	6-7/8 (174)	6-7/8 (174)	6-7/8 (174)	6-7/8 (174)
Air Return Opening Size	H	Air Return Length	38-3/8 (975)	44-5/16 (1125)	50-3/8 (1280)	57-1/4 (1455)
	I	Air Return Width	21-1/8 (536)	21-1/8 (536)	21-1/8 (536)	21-1/8 (536)

## Outdoor Unit Dimension

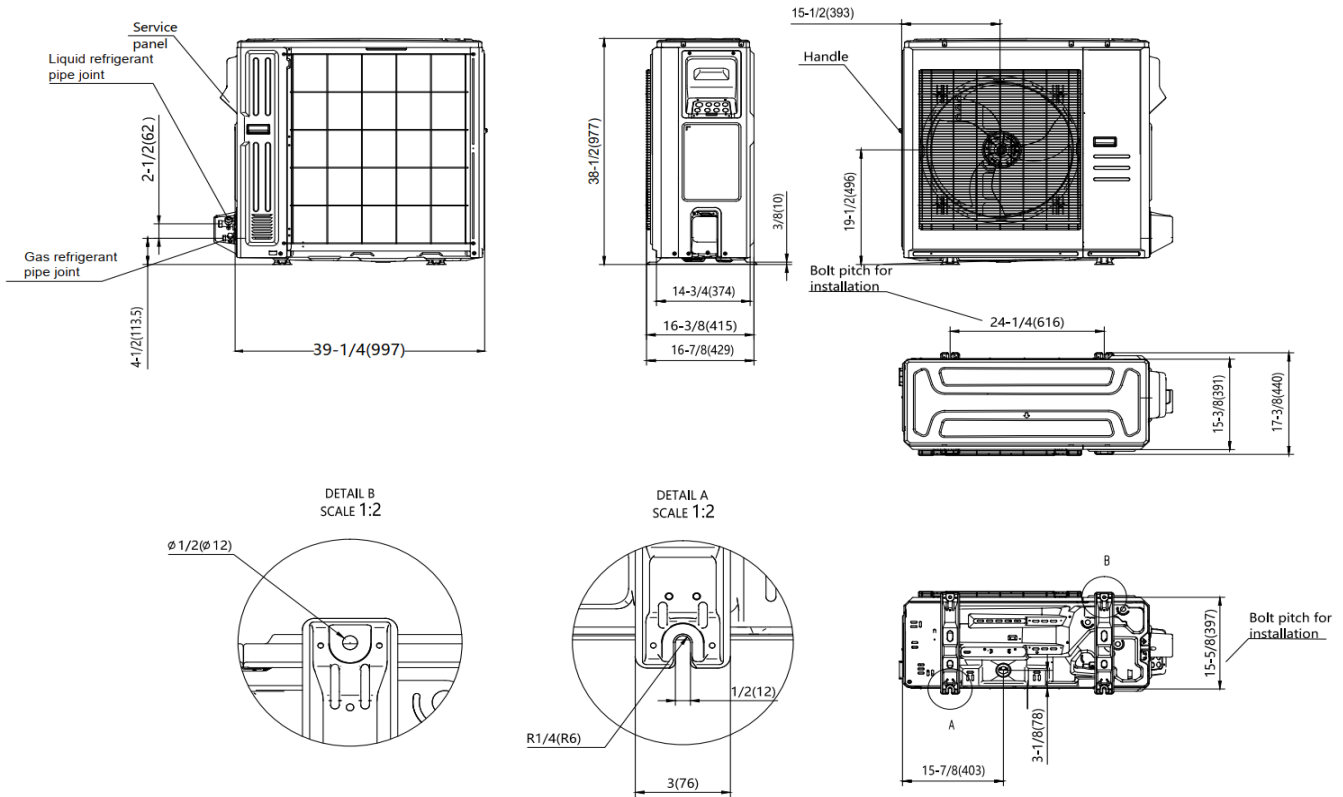

## Installation Instruction For Outdoor Unit

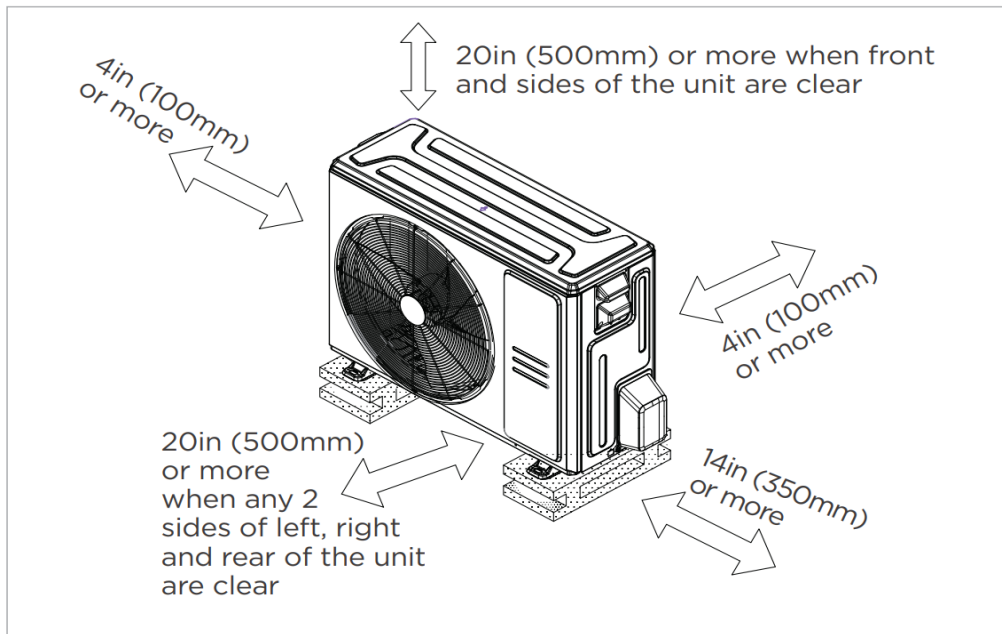

Meets all spatial requirements shown in Installation Clearance Requirements above.

36K

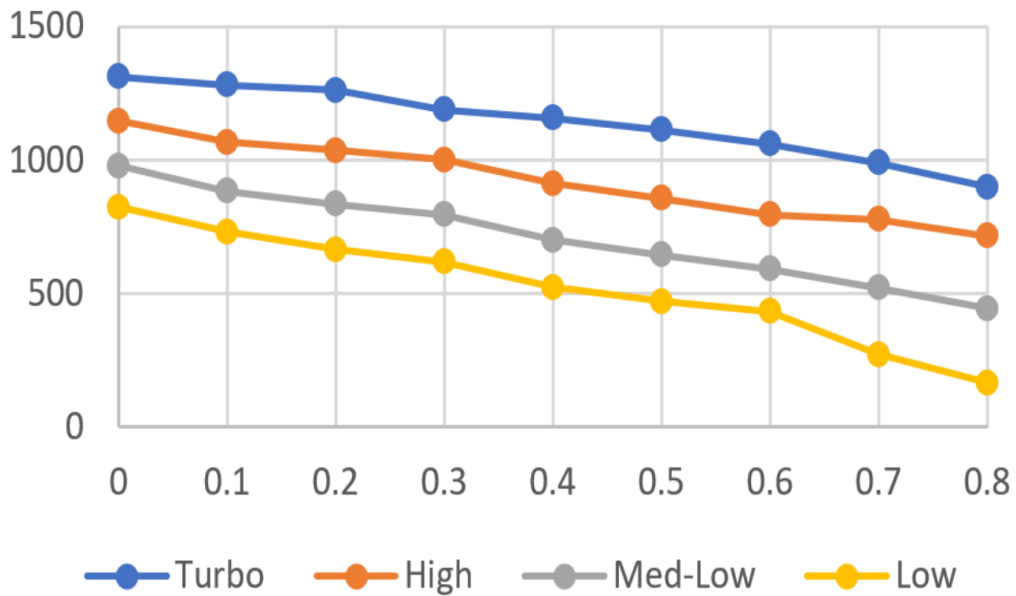

**Features**

- High efficiency up to 16.8 SEER2, 12 EER2, 10.5 HSPF2
- Aluminum Coil
- IDU compatible with 115V and 230V
- Constantly Air Flow system up to 0.80 In.W.G
- Optional Auxiliary heat kit up to 10kW
- Easy Maintenance
- Multiple control options available:
  - Two way communication wired controller:120N(X6)
  - Two way communication wired controller with built-in WiFi:120N(X6W)
  - Wireless remote controller
  - Third-Party 24V Thermostat
- Adaptive Control wiring method on 24V and RS485
- Downward or Backward (optional) air inlet
- Chassis heater and crankcase heater equipped as standard