

Indoor KEENHYMAH18AA
Outdoor KEENHYMHP18AA
High Wall Heat Pump System

Location:	Approval:
Engineer:	Date:
Submitted to:	Construction:
Submitted by:	Unit #:
Reference:	Drawing #:

INDOOR SPECIFICATION

Indoor Air Flow (Turbo/H/M/L/Si) (CFM)	812.3 / 618.0 / 412.0 / 317.8 / 317.8	
Indoor Noise Level (Turbo/H/M/L/Si) (dBA)	54.5 / 43.5 / 38.5 / 27 / 16	
Dimension (WxDxH)	inch	46.85 x 11.20 x 14.59
	mm	1190 x 285 x 371
Package (WxDxH)	inch	50.39 x 14.17 x 17.91
	mm	1280 x 360 x 455
Net/Gross Weight	lbs	43.65 / 55.56
	kg	19.8 / 25.2

OUTDOOR SPECIFICATION

Compressor Type	ROTARY	
Compressor Model	KTM240D46UKT2	
Refrigerant	R454B	
Refrigerant Oil Charge (mL)	620	
Refrigerant Oil	VG74	
Outdoor Air Flow (Max) (CFM)	2235.3	
Outdoor Noise Level (dBA)	61.5	
Dimension (WxDxH)	inch	37.24 x 16.14 x 31.89
	mm	946.0 x 410.0 x 810.0
Package (WxDxH)	inch	42.91 x 19.68 x 34.84
	mm	1090 x 500 x 885
Net/Gross Weight	lbs	130.29 / 141.31
	kg	59.1 / 64.1

EFFICIENCY

Cooling		Heating	
SEER2	25.6	HSPF2-4	16.2
EER2	15.0	COP	4.40

PERFORMANCE of Cooling

Cooling (Btu/hr)	
Rated Capacity	18000
Min/Max Capacity	12600 ~ 27900
Moisture Removal (L/h)	1.1
Standard Operating Range (°F/°C)	-22 ~ 122 (-30 ~ 50)
Conditions:	Indoor: 80°F DB / 67°F WB Outdoor: 95°F DB / 75°F WB

PERFORMANCE of Heating

Heating (Btu/hr)	
1. @ 47°F Rated	20000
1. @ 47°F Min/Max Capacity	9700 ~ 29700
2. @ 17°F Rated	19300
3. @ 5°F Rated: Capacity / COP	22600 / 2.34
3. @ 5°F Max: Capacity	22600
Standard Operating Range (°F/°C)	-22 ~ 75 (-30 ~ 24)
1. Conditions:	Indoor: 70°F DB / 60°F WB Outdoor: 47°F DB / 43°F WB
2. Conditions:	Indoor: 70°F DB / 60°F WB Outdoor: 17°F DB / 15°F WB
3. Conditions:	Indoor: 70°F DB / 60°F WB Outdoor: 5°F DB / 5°F WB

ELECTRICAL

Power Supply	208/230V, 60Hz, 1Ph
System MCA	24.9
Connection Wiring	14#x4
System MOCP	25
Compressor RLA	15.0
Outdoor Fan Motor RLA	1.3
Outdoor Fan Motor W	120
Indoor Fan Motor RLA	1.3
Indoor Fan Motor W	58
System Power Input @ Cooling (W)	1200 (940 ~ 2280)
System Power Input @ Heating (W)	1332 (525 ~ 2440)
MCA: Min. circuit amps (A)	MOCP: Max. over current protection (A)
RLA: Rated load amps (A)	W: Fan motor rated output (W)

PIPING

Throttle Type (Indoor)	N/A
Throttle Type (Outdoor)	EXV + Throttle valve
Liquid Size	9.52mm (3/8in)
Gas Size	15.9mm (5/8in)
Max. Piping Length (ft/m)	164.00 (50)
Max. Height Difference (ft/m)	82.00 (25)
Max. Pre-charged Length (ft/m)	24.6 (7.5)
Refrigerant Pre-charged Amount (oz/g)	63.49 (1.8)
Additional Charge of Refrigerant ((oz/ft) / (g/m))	0.32 (30)
Connection Method	Flared

Indoor Unit Dimension

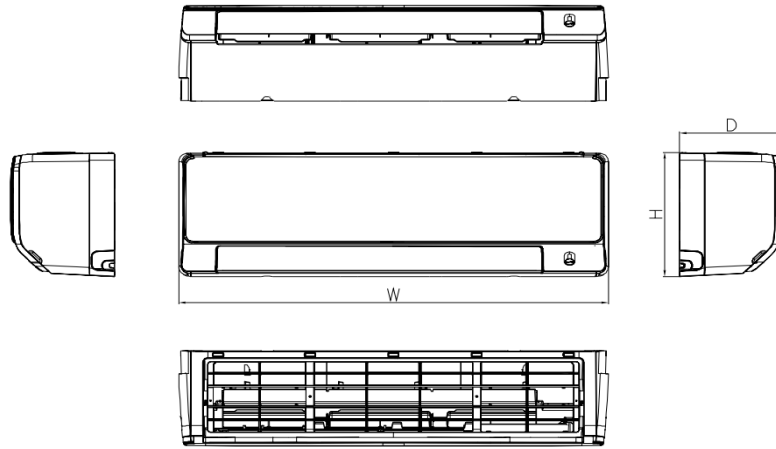

Capacity	Body Code	Unit	W	D	H
6k~12k	C	mm	1017	248	319
		inch	40	9-3/4	12-1/2
18k	D	mm	1190	285	371
		inch	46-7/8	11-1/4	14-5/8

Installation Instruction

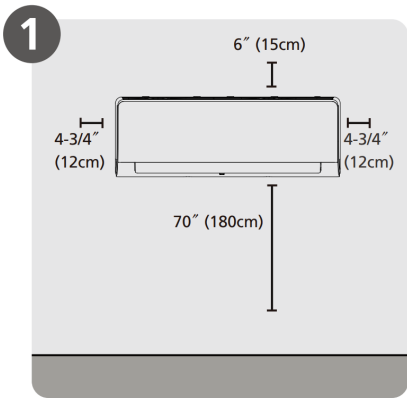

Select Installation Location

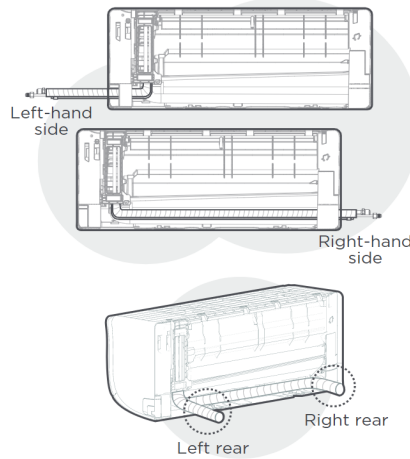

NOTE:
Based on the position of the wall hole relative to the mounting plate, choose the side from which the piping will exit the unit. You have four options for the exit direction of the piping.

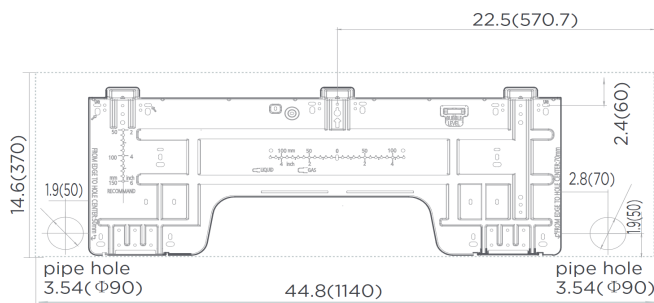

NOTE:
When the gas side connective pipe is Φ (5/8in)16mm or more, the wall hole should be (3-1/2in)90mm.

Outdoor Unit Dimension

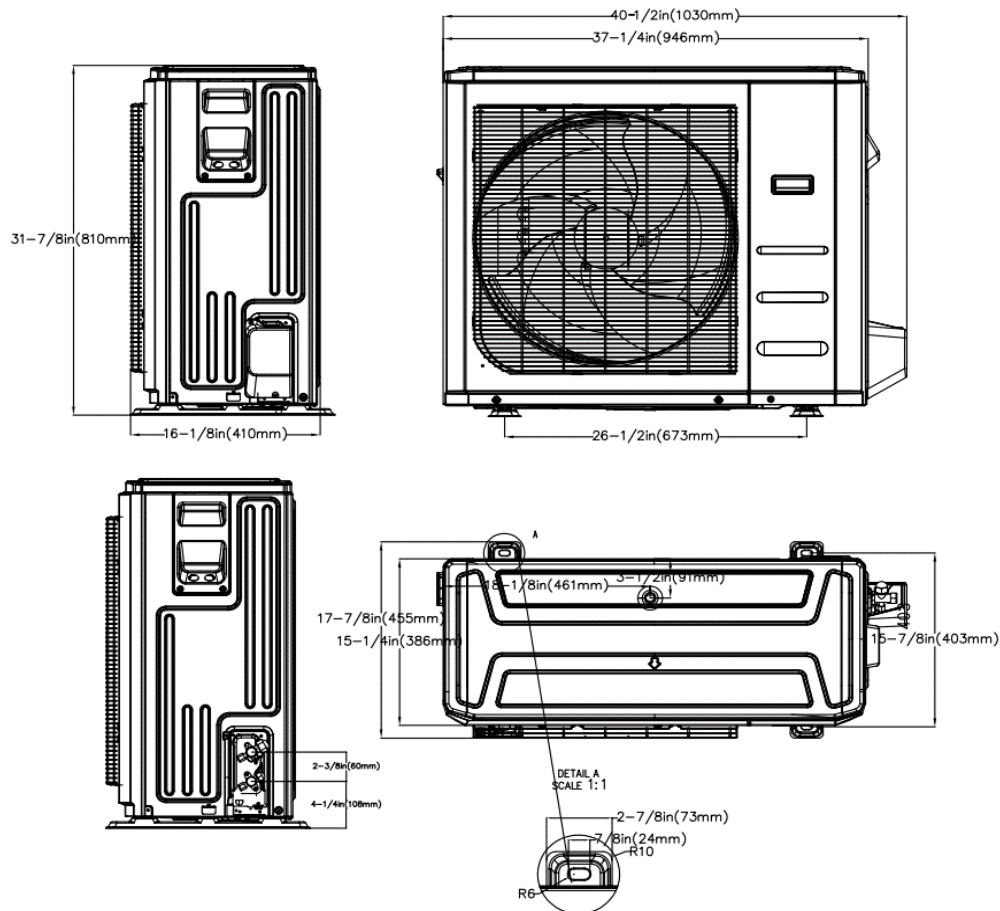

Installation Instruction

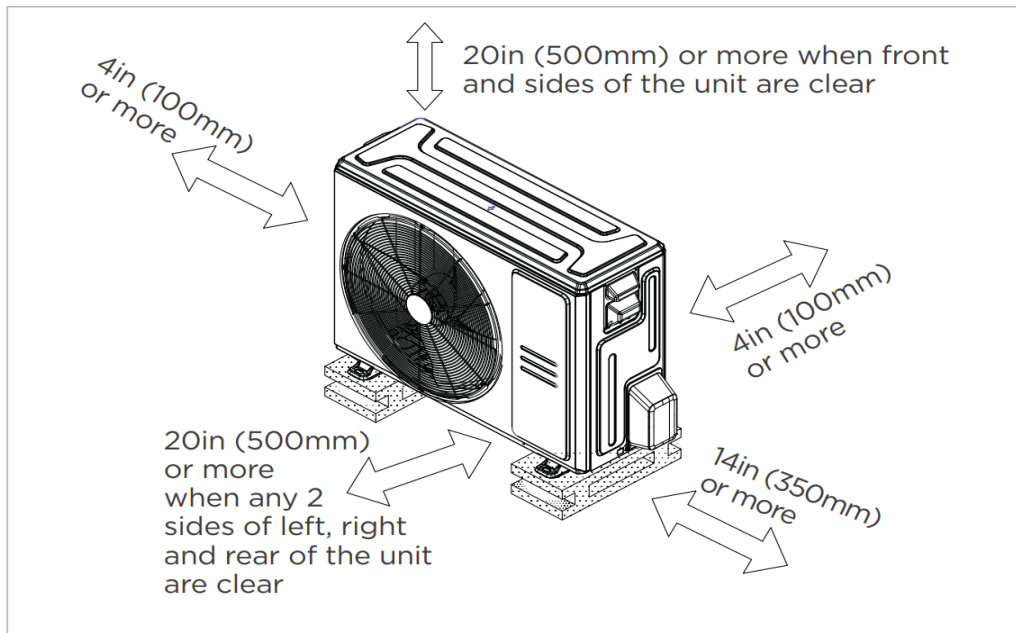

Meets all spatial requirements shown in Installation Clearance Requirements above.