

Indoor: KEENHYDAH60AA

Outdoor KEENHYDHP60AA

Air Handler Heat Pump System

Location:	Approval:
Engineer:	Date:
Submitted to:	Construction:
Submitted by:	Unit #:
Reference:	Drawing #:



INDOOR SPECIFICATION		
ESP (in WG)		0 - 0.8
Indoor Air Flow (Turbo/H/M/L/Si) (CFM)		1807.0 / 1583.3 / 1359.7 / 1136.0 / N/A
Indoor Noise Level (Turbo/H/M/L/Si) (dBA)		54.5 / 52 / 49.5 / 34.5 / N/A
Dimension (W×D×H)	inch	21.02 x 24.49 x 52.99
	mm	534.0 x 622.0 x 1346.0
Package (W×D×H)	inch	27.95 x 26.77 x 56.50
	mm	710 x 680 x 1435
Net/Gross Weight	lbs	162.92 / 190.92
	kg	73.9 / 86.6

OUTDOOR SPECIFICATION		
Compressor Type		TWIN-ROTARY
Compressor Model		ETPQ480D66UMU1
Refrigerant		R454B
Refrigerant Oil Charge (mL)		1300
Refrigerant Oil		VG75
Outdoor Air Flow (Max) (CFM)		2648.6
Outdoor Noise Level (dBA)		65
Dimension (W×D×H)	inch	37.48 x 16.34 x 52.48
	mm	952.0 x 415.0 x 1333.0
Package (W×D×H)	inch	43.11 x 19.49 x 58.27
	mm	1095 x 495 x 1480
Net/Gross Weight	lbs	242.95 / 275.13
	kg	110.2 / 124.8

EFFICIENCY			
Cooling		Heating	
SEER2	16.0	HSPF2-4	9.0
EER2	10.0	COP	3.10

PERFORMANCE of Cooling	
Cooling (Btu/hr)	
Rated Capacity	54000
Min/Max Capacity	11400~56300
Moisture Removal(L/h)	5.87
Standard Operating Range(*F/*C)	-22~122 (-30 ~ 50)
Rated Cooling Conditions:	Indoor: 80°F DB / 67°F WB Outdoor: 95°F DB / 75°F WB

PERFORMANCE of Heating	
Heating (Btu/hr)	
1. @ 47°F Rated	56000
1. @ 47°F Min/Max Capacity	8100~64500
2. @ 17°F Rated	45000
3. @ 5°F Rated: Capacity / COP	52000 / 1.8
3. @ 5°F Max: Capacity	52000
Standard Operating Range (*F/*C)	-22~75 (-30 ~ 24)
1. Rated Heating Conditions:	Indoor: 70°F DB / 60°F WB Outdoor: 47°F DB / 43°F WB
2. Rated Heating Conditions:	Indoor: 70°F DB / 60°F WB Outdoor: 17°F DB / 15°F WB
3. Heating Conditions, Compressor Operating at Max. Frequency	Indoor: 70°F DB / 60°F WB Outdoor: 5°F DB / 5°F WB

ELECTRICAL	
Indoor Power Supply	115 / 208 / 230V, 60Hz, 1Ph
Indoor MCA 115V/(208/230V)	14.5 / 11.0
Indoor MOP	15
Outdoor Power Supply	208 / 230V, 60Hz, 1Ph
Outdoor MCA	40
Outdoor MOP	40
Communication Wiring	AWG 20-2
Compressor RLA	31
Outdoor Fan Motor RLA	1.2
Outdoor Fan Motor W	85
Indoor Fan Motor RLA	8.3
Indoor Fan Motor W	750
System Power Input @ Cooling (W)	5400 (1540 ~ 6430)
System Power Input @ Heating (W)	5300 (725 ~ 5970)
MCA: Min. circuit amps (A)	MOCP: Max. over current protection (A)
RLA: Rated load amps (A)	W: Fan motor rated output (W)

PIPING	
Throttle type (Indoor)	EXV
Throttle type (Outdoor)	EXV
Liquid Size	9.52mm (3/8in)
Gas Size	19mm (3/4in)
Max. Piping Length (ft/m)	246 (75)
Max. Height Difference (ft/m)	98.4 (30)
Max. Pre-charged Length (ft/m)	24.6 (7.5)
Refrigerant Pre-charged Amount (oz/kg)	183.42 (5.2)
Additional Charge of Refrigerant ((oz/ft) / (g/m))	0.7 (65)
Connection Method	Flared

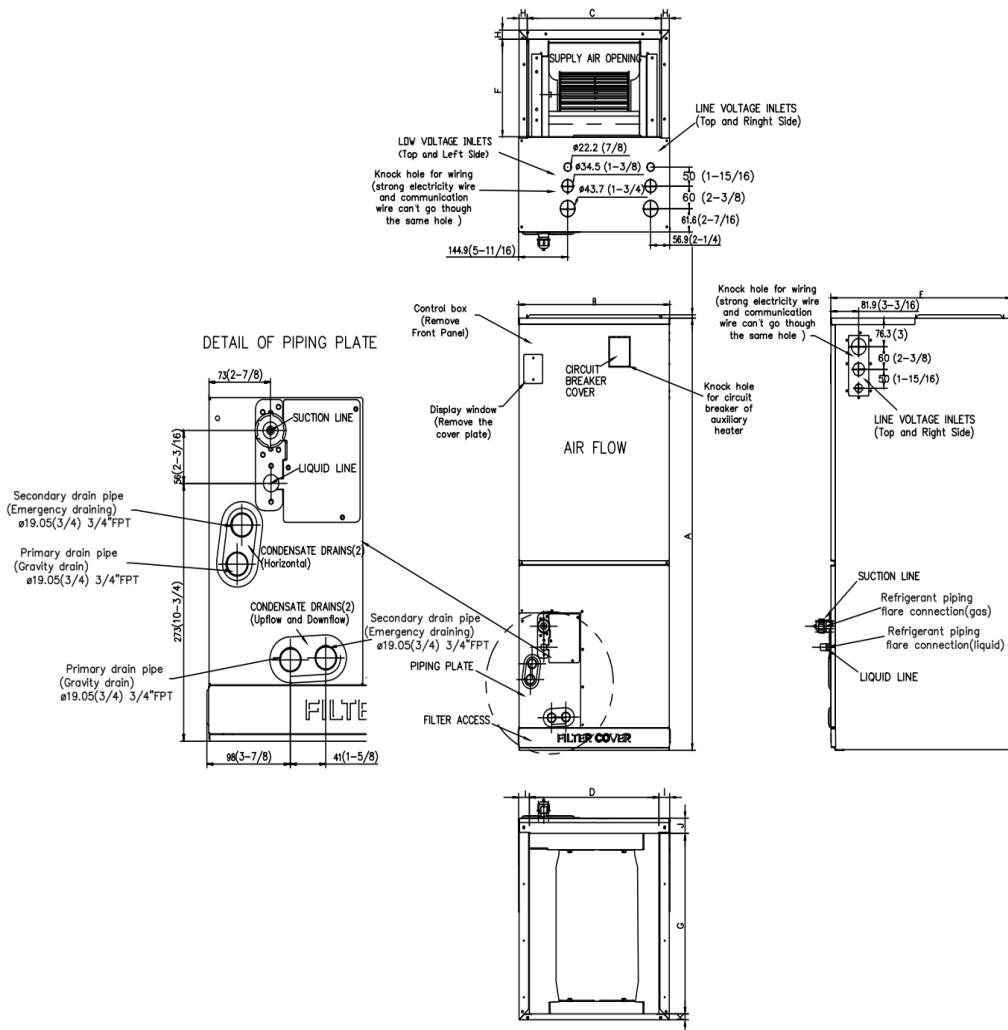

Dimensions	Model	18k/24k		30k/36k		48k/60k	
		inch	mm	inch	mm	inch	mm
A	Model Height	45	1143	49	1245	53	1346
B	Model Width	17-1/2	445	21	534	24-1/2	622
C	Supply Air Opening Width	15-5/8	397	19-1/8	486	22-5/8	575
D	Return Air Opening Width	15-1/8	384	18-5/8	473	22-1/8	562
E	Model Depth	21	534	21	534	21	534
F	Supply Air Opening Depth	10-1/4	260	10-1/4	260	10-1/4	260
G	Return Air Opening Depth	18-3/4	476	18-3/4	476	18-3/4	476
H	Supply Air Opening Clearance	15/16	24	15/16	24	15/16	24
I	Return Air Opening Side Clearance	1-1/4	32	1-1/4	32	1-1/8	28
J	Return Air Opening Front Clearance	1-1/2	38	1-5/8	41	1-5/8	41
K	Return Air Opening Back Clearance	5/8	16	5/8	16	3/4	19

Outdoor Unit Dimension

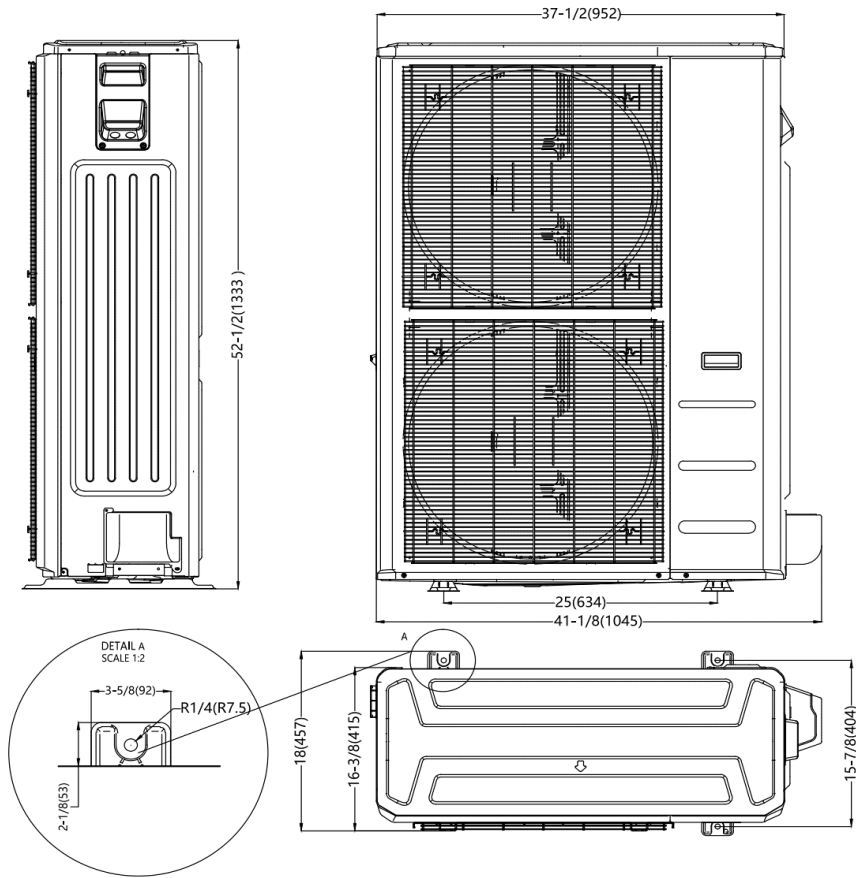

Installation Instruction For Outdoor Unit

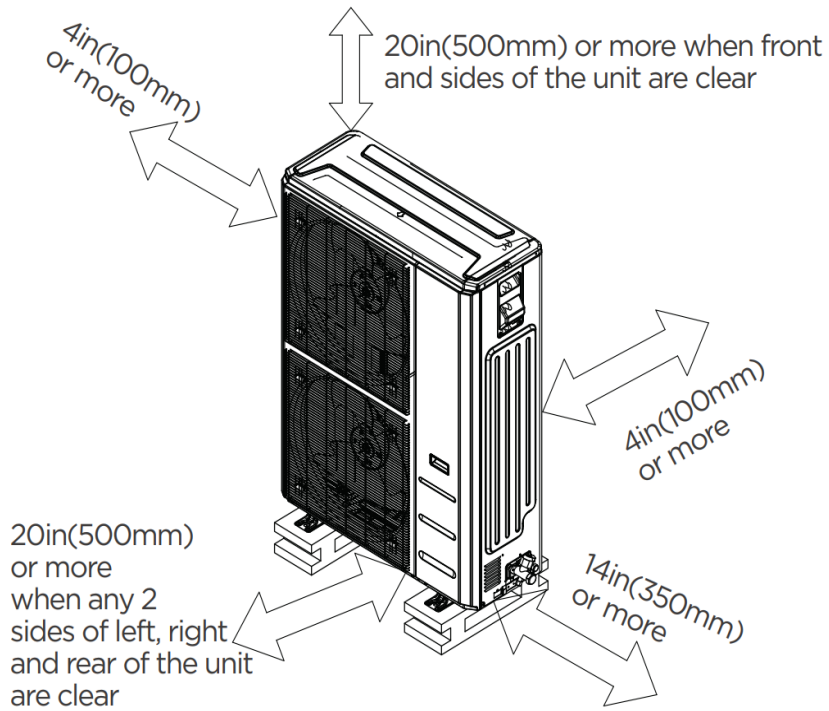

Fan Performance For Indoor Unit

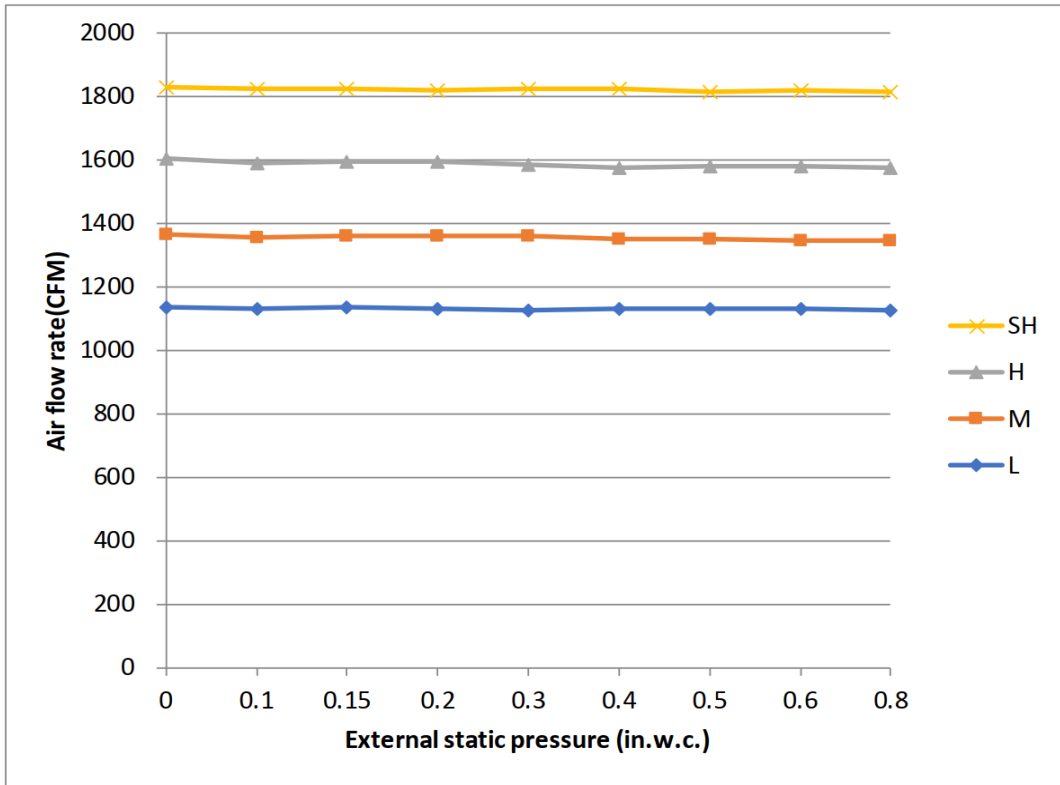

Features

- Multi-position installation: horizontal (left or right), vertical (up or down)
- Aluminum Coil
- Constantly Air Flow system up to 0.80 In.W.G
- 1 inch R4.2 fiberglass free insulation reduces condensation and boosts efficiency (optional)
- Optional Auxiliary heat kit up to 25kW
- Easy Maintenance
- Multiple control options available:
 - Two way communication wired controller:120N(X6)
 - Two way communication wired controller with built-in WiFi:120N(X6W)
 - Wireless remote controller
 - Third-Party 24V Thermostat
- Adaptive Control System
- High efficiency up to 19 SEER2, 12.5 EER2, 10.3 HSPF2
- 100% heat output at -4F*
- Chassis heater and crankcase heater equipped as standard

* For 36K model, rated cooling capacity/heating capacity at -4F=100%