

aerocoach

Brute Track Crankset

Installation and Usage Instructions

Before installation and use, read the following instructions carefully and retain for future use. An up to date version of this document is also available at www.aero-coach.co.uk/manuals-and-downloads

Brute Track Crankset Installation

To correctly install the Brute Track Crankset, the following tools are required:

- 8mm Allen Key
- T25 Torx Key
- 2mm Allen Key
- Torque Wrench with 8mm, T25 and 2mm bits

1. Install your bottom bracket (not included) as per the manufacturers instructions. The Brute Track Crankset is intended for use with a 24mm bottom bracket.

NOTE - The Brute Track Crankset is designed to work without bottom bracket spacers. It is recommended to remove any bottom bracket spacers before installation.

2. Use a 2mm Allen key to remove the three Cover Bolts (1) securing the Spider Cover (2).

3. Align your Spider (4) with the interface on the rear of the Right Crank (3) and install the Spider Bolts (5). Tighten to 2-3Nm.

4. Apply a light layer of grease to the Axle (7) interface and anti-seize to the threads on the crank bolt and Axle (7). Ensuring the parts are aligned correctly, tighten the Right Crank (3) onto the Axle (7) using an 8mm allen key. Tighten the crank bolt to 48-50Nm using a torque wrench.

5. Insert the Axle (7) into the bottom bracket from the drive-side of the bicycle. Press firmly as this should be a snug fit.

6. Slide the wave washer (8) onto the end of the axle on the non-drive-side and apply a light layer of grease to the threads and interface of the Axle (7) and the threads of the crank bolt.

7. Ensuring the parts are aligned correctly, tighten the Left Crank (9) onto the axle using an 8mm allen key. Before fully tightening, check that the Wave Washer (8) is seated correctly and is compressed evenly. Tighten the crank bolt to 48-50Nm using a torque wrench.

8. Check for lateral play in the cranks. Depending on your bottom bracket you may need to add axle spacers. To do this remove the Left Crank (9) by undoing the crank bolt and repeat steps 2-5 with additional Axle Spacers (6) as required to eliminate play.

NOTE - it is recommended to add spacers one at a time to alternate sides starting on the non-drive

side and fully installing the crankset before checking for play with each additional spacer. *Adding too many spacers may compromise the performance of and/or cause damage to your Brute Track Crankset and/or bottom bracket.*

NOTE - If your bottom bracket has additional dust covers, you may need to remove these to achieve the correct preload on you bottom bracket bearings. Please be aware that a dust cover is different to a 'top hat' cover that reduces the bore of the bearing. *If you have a 'top hat' cover, DO NOT remove this as it is crucial to your bottom bracket operating correctly.*

9. Once the Brute Track Crankset is installed with no lateral play, fix the Crank Bolt Cover (10) to the Left Crank (9) and the Spider Cover (2) to the Right Crank (3) using the Cover Bolts (1) and a 2mm allen key. Tighten to a torque of 1-2Nm.

Spider Installation

You may wish to switch between power and non-power spiders on your Brute Track Crankset. To change the spider, use the following instructions:

1. If it is already installed, remove the Brute Track Crankset from your bicycle.

2. Undo the three Spider Bolts (5) on the rear of the Spider (7) using a T25 Torx key. You should not need to remove the axle to access these bolts.

3. Remove the Spider (7) and install your replacement according to steps 3 and 4 of the Brute Track Crankset installation instructions.

NOTE - If you you have changed your Spider (7) more than 5 times, we recommend reapplying a medium strength thread lock to the Spider Bolts (5).

4. Reinstall your Brute Track Crankset using the installation instructions.

Usage

If you have the power2max spider for the Brute Track Crankset, the power meter charging port can be accessed by removing the Spider Cover (2) on the Right Crank (3). To do so, remove the three Cover Bolts (1) on the outside face of the Spider Cover (2) using a 2mm allen key. When reinstalling, these bolts should be tightened to 1-2Nm.

For information regarding the operation and maintenance of the power2max power meter spider, please refer to the manufacturer instructions included.

aerocoach

Brute Track Crankset

Installation and Usage Instructions

The Brute Track Crankset is intended for indoor velodrome use with track bicycles only. Please check your bicycle and bottom bracket for compatibility before installation and use.

Maintenance

It is recommended to regularly check the crankset for play and ensure the crank bolts remain tightened to the correct torque.

Use only AeroCoach or AeroCoach approved spare or replacement parts.

PLEASE NOTE

Always check your bicycle before use. If you see or suspect any damage, do not ride your bicycle until it has been professionally inspected.

In the case of a crash or impact, do not ride your bicycle until it has been professionally inspected.

Do not modify your Brute Track Crankset in any way.

AeroCoach Ltd does not accept any liability for issues arising due to non-compliance of these instructions.

Warranties and guarantees for any AeroCoach product are applicable to the original purchaser only.

If you are uncertain about anything mentioned in this manual or require more guidance, please contact customerservice@aero-coach.co.uk

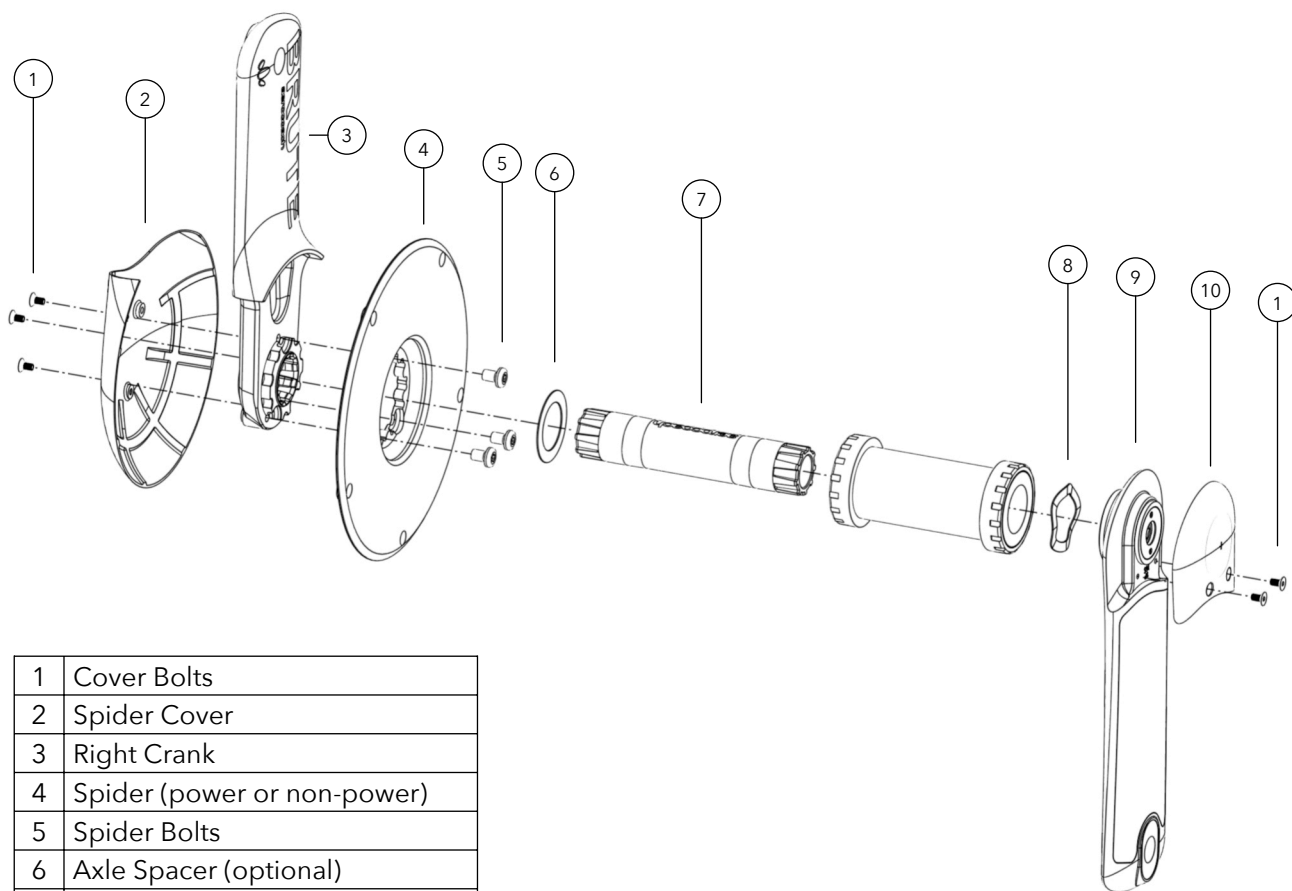

1	Cover Bolts
2	Spider Cover
3	Right Crank
4	Spider (power or non-power)
5	Spider Bolts
6	Axle Spacer (optional)
7	Axle
8	Wave Washer
9	Left Crank
10	Crank Bolt Cover