

# PRÁTICA



**Product** **2026**  
catalog EMEA

# Welcome to *Prática*



Prática, founded in 1991, offers advanced equipment for the food preparation market, with a broad product portfolio that includes a strong range of speed ovens. The company operates a fully integrated 250,000 sq. ft. manufacturing facility in Minas Gerais, Brazil, employing more than 700 team members—55 of whom are dedicated to Research & Development.

Prática maintains a growing international presence with branches in the United States, Europe, and Chile, and exports its products to over 60 countries worldwide.

Our purpose is to empower customers to prepare high-quality food without waste. We understand the important role we play in the food chain that begins in the fields where crops are grown and ends when food is prepared and served. Through state-of-the-art technology, integrated product solutions, and robust pre- and post-sales support, we enhance our customers' operations in quality, productivity, and profitability.

Guided by strong values, a unified team, and a forward-looking vision, Prática is steadily advancing toward an increasingly prominent position in the global foodservice industry.

# Purpose

Prática's purpose is to help our customers prepare quality food without waste.

This purpose, also a commitment, unfolds into three complementary dimensions: well-being, productivity, and preservation. We believe that when we execute our work with excellence and stay true to this purpose, we contribute to the well-being of people, support growth and development opportunities for our customers, and help preserve our shared home: planet Earth.

Quality food  
without waste.



Well-being



Productivity



Sustainability

# Vision

To be a world-class company with global impact, recognized for excellence in our service, products, operations, and leadership.

# Values



COMPETITIVENESS



DEDICATION TO  
THE CUSTOMER



RESPECT



AGILITY



COMMITMENT



PROACTIVITY



WILLINGNESS  
TO IMPROVE



INNOVATION



SPIRIT OF  
COLLABORATION



HONESTY AND  
INTEGRITY



AUSTERITY



GRATITUDE

# Present in over 60 countries

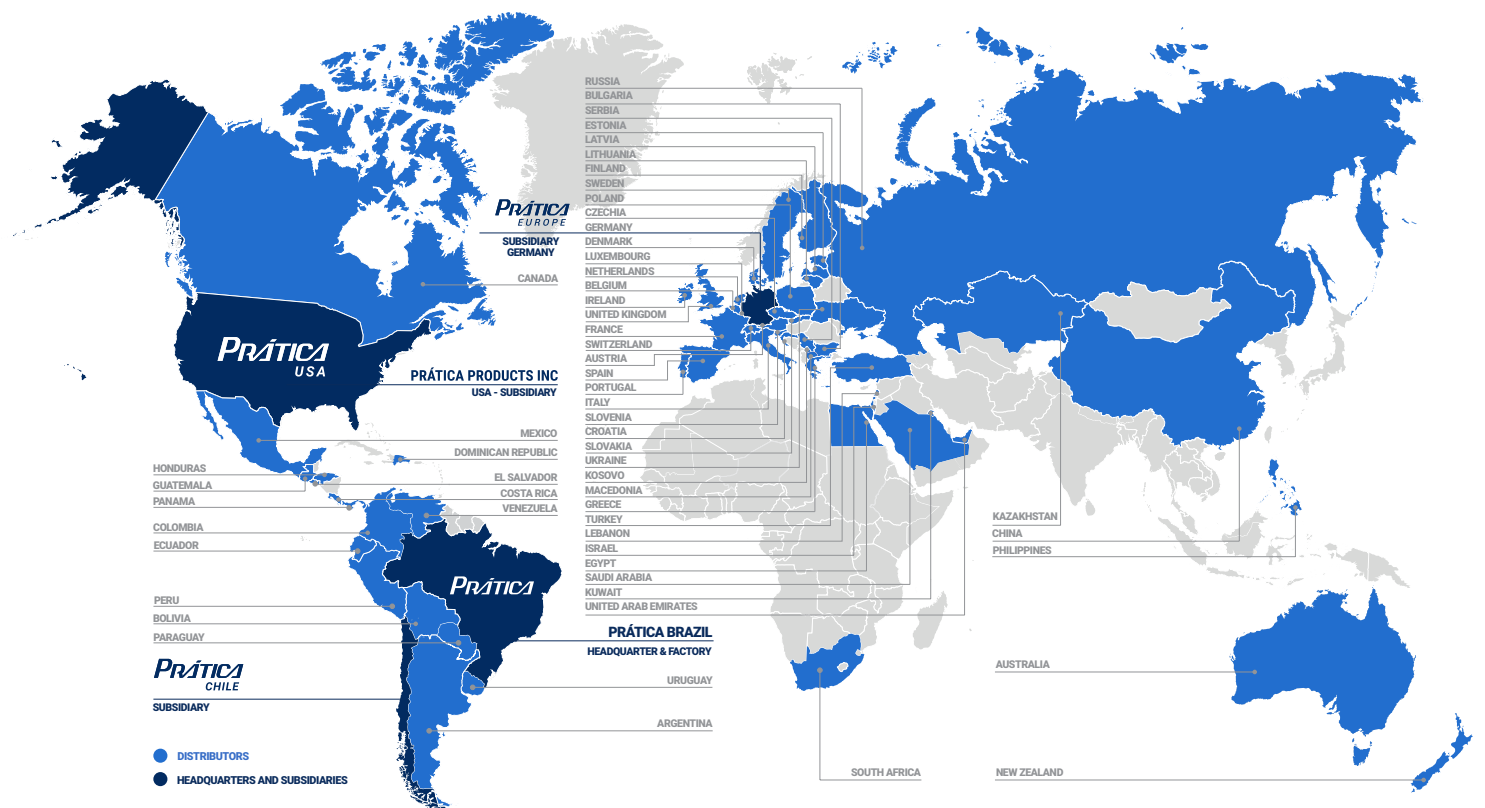

 Zoom in to get a better view.



**7** Speed Ovens

**8** Fit Express

**10** Fit Lite

**12** Fit SM

**14** Fit XL

**16** Fit ST

**18** Panini Press

**21** Technology

**26** Accessories

**28** Combi Ovens

**30** TSi Brave

**32** Convection  
Ovens

**34** Miniconv

**36** Miniconvx HP

**38** HPE80  
Programmable



# Speed Ovens

Prática's speed ovens are ultra-fast, high-performing ovens used for preparing and finishing fresh, refrigerated, or frozen foods. Each use results in excellent appearance, crunchiness, and taste.

With cutting-edge technology, the ovens work with multiple heat sources, such as impinged hot air, microwave, and direct radiation. They are equipped with a ventless system through an easily removable catalytic converter and require no extraction hood for operation, making it easy to clean and maintain.

With a friendly touchscreen interface, Prática speed ovens have easy operation and quick preparations and are ideal for service with agility and quality.



Fit Line

# Fit Express

The Fit Express high-speed oven is designed to efficiently finish refrigerated, fresh, or frozen foods, such as breakfast sandwiches, chicken wings, muffins, lasagnas, mac & cheese, sub sandwiches, and other partially prepared dishes. It delivers excellent flavor, appearance, and crispiness. The combination of impinging air and microwaves allows for heating, browning, or toasting foods faster than traditional methods.



## Colors

Fit Express Black

Fit Express Silver

- ✔ Fits on 15.2" width countertops and cooks 12" pizzas.
- ✔ User interface: full-color user-friendly touchscreen display. Drag and drop features.
- ✔ IOK: Create, edit, and organize groups, recipes, and complete menus directly on the oven or from your computer using Wi-Fi or USB flash drive and send them to all connected ovens.
- ✔ Multi-language system: Portuguese, English, Spanish, French, German, Polish, Russian, Mandarin, Greek.
- ✔ Ventless: no hoods needed.
- ✔ The removable catalytic converter allows operators to perform the cleaning without the need for a maintenance service call.
- ✔ Secures consistent results: through precise control, even heat distribution, rapid cooking, built-in sensors, and customization options, ensuring uniform and efficient cooking for reliable outcomes.
- ✔ Independently adjust microwave power, temperature, and impinged air while programming recipes on the oven.
- ✔ No side vents, allowing zero side clearance.
- ✔ Elegant & Intuitive: Stores unlimited recipes, with their own steps, settings, icons, or photos.
- ✔ Temperatures up to 536°F: The impinged air convection technology combined with microwave capabilities enables users to cook food faster than when using traditional processes.
- ✔ Heat insulation: prevents the surrounding area from heating up and keeps the surface cool to the touch.

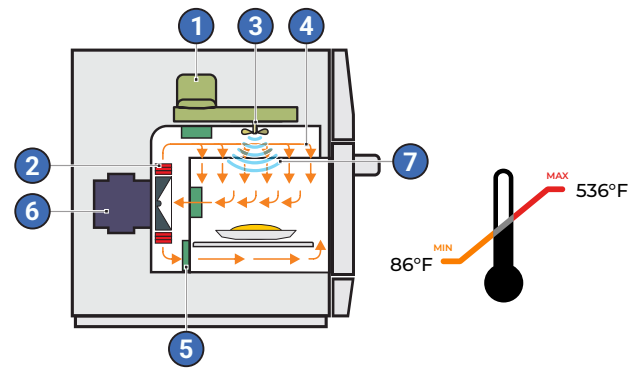

- 1. Magnetron
- 2. Resistance (infrared)
- 3. Stirrer
- 4. Impinged Air
- 5. Catalytic Converter
- 6. Blower Motor
- 7. Microwaves

## Cook Times

Ham & Cheese Panini	50 sec
Italian Sub	55 sec
Fresh Omelet	1 min 30 sec
Frozen Pizza 30cm	2 min
Steamed Salmon	2 min 30 sec



CERTIFIED  
**VENTLESS**  
WITH EASILY REMOVABLE  
CATALYTIC CONVERTER.

### Standard accessories



[Click to learn more](#)

**1 year warranty** for parts and labor, with the exception of naturally worn items.

Fit Express											
Region	Voltage (V)	Phases	Freq. (Hz)	Power (kW)	Circuit breaker (A)	Cable	Socket	Product dimensions (Height x Width x Depth)	Boxed product dimensions (Height x Width x Depth)	Chamber dimensions (Height x Width x Depth)	Clearance (Left   Back   Right side)
Europe	230	Single	50	6.8	32	3x4	32A(2P+E)	659 x 386 x 693 (mm) 71.3kg	850 x 510 x 900 (mm) 87kg	133 x 315 x 308 (mm) 13L	0 / 0 / 0 (mm)
	380	Multi		6.5	16	5x2,5	16A(3P+N+E)				
	400	Multi		6.8	16	5x2,5	16A(3P+N+E)				

\*Prática recommends installing a type D circuit breaker. The electrical installation must comply with local regulations.



## Fit Line **Fit Lite**

The Fit Lite high-speed oven is designed for the regeneration and finishing of fresh or refrigerated food items, such as sandwiches, pizzas, pastries, and other pre-prepared products. It delivers consistent results in heating, browning, and gratinating, ensuring uniform appearance and texture. By combining high-speed impinged air with microwave energy, the Fit Lite reduces preparation time compared to traditional cooking methods while maintaining product quality. The Fit Lite is not recommended for frozen food.



# Colors

Fit Lite Silver

- ✔ Ideal for fresh or refrigerated food items. Not recommended for frozen food.
- ✔ Designed for regeneration, finishing, and gratination of pre-prepared food.
- ✔ Countertop speed oven developed for commercial foodservice applications.
- ✔ Cooking technology combines high-speed impinged air and microwave energy for faster preparation compared to conventional methods.
- ✔ User interface: full-color touchscreen display for recipe selection and operation.
- ✔ Recipe programming: independently adjust microwave power, temperature, air speed, and cooking time.
- ✔ Multi-step recipes: allows up to 8 programmable steps per recipe.
- ✔ Recipe and settings transfer via USB flash drive.
- ✔ Manual mode available for testing preparations and developing new recipes.
- ✔ Speed Grill required during operation to ensure proper cooking performance.
- ✔ Maximum temperature up to 280°C (536°F).

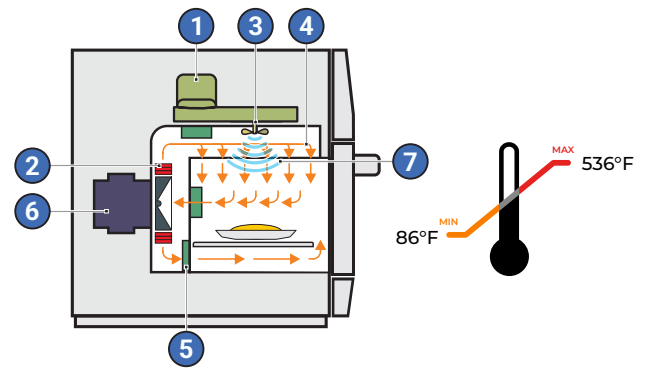

- 1. Magnetron
- 2. Resistance (infrared)
- 3. Stirrer
- 4. Impinged Air
- 5. Catalytic Converter
- 6. Blower Motor
- 7. Microwaves

## Cook Times

Pastries	25 sec
Sub Sandwiches	1 min
Hot Dog	50 sec
Paninis	1 min



### Standard accessories



Speed Grill



Aluminum Paddle

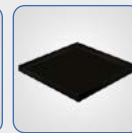

Solid Basket



**1 year warranty** for parts and labor, with the exception of naturally worn items.

Fit Lite											
Region	Voltage (V)	Phases	Freq. (Hz)	Power (kW)	Circuit breaker (A)	Cable	Socket	Product dimensions (Height x Width x Depth)	Boxed product dimensions (Height x Width x Depth)	Chamber dimensions (Height x Width x Depth)	Clearance (Left   Back   Right side)
United Kingdom	230	Single	50	3	13	3x1,5	13A(2P+E)	619 x 386 x 680 (mm) 56kg	850 x 510 x 900 (mm) 72kg	133 x 315 x 308 (mm) 13L	0/0/0 (mm)
Europe	230	Single	50	3.4	16	3x2,5	16A(2P+E)	619 x 386 x 680 (mm) 56kg	850 x 510 x 900 (mm) 72kg	133 x 315 x 308 (mm) 13L	0/0/0 (mm)

\*Prática recommends installing a type D circuit breaker. The electrical installation must comply with local regulations.



## Fit Line **Fit SM** Single mag

The Fit Single Mag high-speed oven is designed to efficiently finish refrigerated or fresh food items, such as breakfast sandwiches, pizzas, sub sandwiches, pastries and more! It delivers excellent flavor, appearance, and crispiness. The combination of impinged air and microwaves allows for heating, browning, or toasting foods faster than traditional methods. The Fit SM is not recommended for frozen food.



# Colors

Fit SM Silver

- ✔ Ideal for fresh or refrigerated food items. Not recommended for frozen food.
- ✔ Energy efficient: It is designed to be energy-efficient, so you save money on electricity compared to other models.
- ✔ Fits on 15.2" width countertops and cooks 12" pizzas and sandwiches.
- ✔ User interface: full-color user-friendly touchscreen display. Drag and drop features.
- ✔ IOK: Create, edit, and organize groups, recipes, and complete menus directly on the oven or from your computer using Wi-Fi or USB Flash Drive and send them to all connected ovens.
- ✔ Ventless: no hoods needed.
- ✔ The removable catalytic converter allows operators to perform the cleaning without the need for a maintenance service call.
- ✔ Independently adjust microwave power, temperature, and impinged air while programming recipes on the oven.
- ✔ No side vents, allowing zero side clearance.
- ✔ Elegant & Intuitive: Stores unlimited recipes, with their own steps, settings, icons, or photos.
- ✔ Temperatures up to 536°F: The impinged air convection technology combined with microwave capabilities enables users to cook food faster than when using traditional processes.
- ✔ Heat insulation: prevents the surrounding area from heating up and keeps the surface cool to the touch.

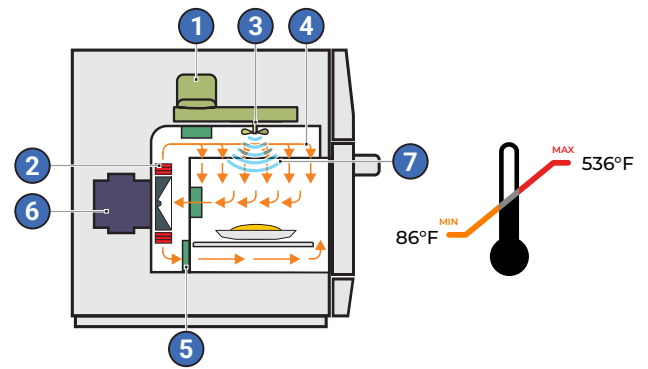

- 1. Magnetron
- 2. Resistance (infrared)
- 3. Stirrer
- 4. Impinged Air
- 5. Catalytic Converter
- 6. Blower Motor
- 7. Microwaves

## Cook Times

Pastries	25 sec
Sub Sandwiches	40 sec
Hot Dog	50 sec
Paninis	1 min 10 sec



CERTIFIED  
**VENTLESS**  
WITH EASILY REMOVABLE  
CATALYTIC CONVERTER.

### Standard accessories

**BUILT-IN**

Speed Grill

Aluminum Paddle

Solid Basket

**Click to learn more**

**1 year warranty** for parts and labor, with the exception of naturally worn items.

Fit SM Single Mag											
Region	Voltage (V)	Phases	Freq. (Hz)	Power (kW)	Circuit breaker (A)	Cable	Socket	Product dimensions (Height x Width x Depth)	Boxed product dimensions (Height x Width x Depth)	Chamber dimensions (Height x Width x Depth)	Clearance (Left   Back   Right side)
Europe	230	Single	50	3	13 16	3x1,5	13A(2P+E) 16A(2P+E)	619 x 386 x 693 (mm) 62kg	850 x 510 x 900 (mm) 77.7kg	133 x 315 x 308 (mm) 13L	0 / 0 / 0 (mm)

\*Prática recommends installing a type D circuit breaker. The electrical installation must comply with local regulations.



## Fit Line Fit XL

The Fit XL high-speed oven features a 16-inch chamber and is designed to efficiently finish refrigerated, fresh, or frozen foods, such as breakfast sandwiches, chicken wings, muffins, lasagnas, mac & cheese, sub sandwiches, and other partially prepared dishes. Capable of handling larger portions, it is ideal for medium and large businesses. The Fit XL delivers excellent flavor, appearance, and crispiness. By combining impinged air and microwaves, it heats, browns, and toasts foods faster than traditional methods.



# Colors

Fit XL Black  
Fit XL Silver

BACK TO MENU

- ✔ 16-inch chamber.
- ✔ Capable of handling larger portions, it is ideal for medium and large businesses.
- ✔ Stores unlimited recipes with up to 8 steps each, divided into 16 groups.
- ✔ USB port for system updates and importing/exporting groups, recipes, and settings.
- ✔ Wi-Fi capabilities, enabling remote management for system updates and importing/exporting groups, recipes, and settings via the IOK online platform.
- ✔ Adjustable temperature from 86°F (30°C) to 536°F (280°C).
- ✔ Independent control of impinged air (high-speed air blast) and microwaves.
- ✔ User-friendly touchscreen panel.
- ✔ Constructed from stainless steel.
- ✔ Certified Ventless – no need for vent hoods. Easy-to-remove catalytic converter for hassle-free cleaning.
- ✔ Additional functionalities: Test Mode and Favorites.
- ✔ Daily cleaning guide with explanatory videos displayed on the screen, demonstrating the step-by-step process.
- ✔ Warranty: one (1) year covering manufacturer defects, part failures, and pre-approved labor, and two (2) years on all the heating elements, magnetrons, and blower motor of the oven.

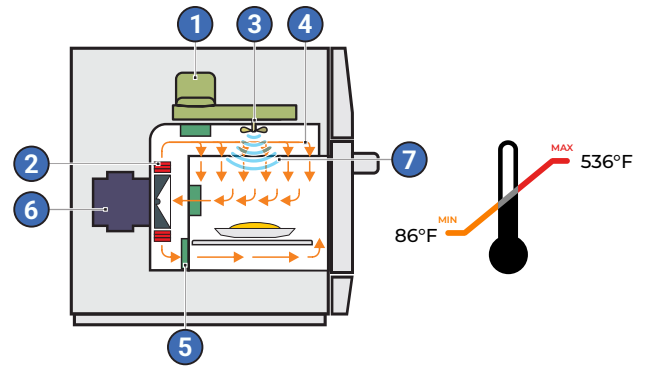

1. Magnetron
2. Resistance (infrared)
3. Stirrer
4. Impinged Air
5. Catalytic Converter
6. Blower Motor
7. Microwaves

## Cook Times

Frozen Pizza 40cm	3 min 30 sec
3 Sub Sandwiches	1 min
6 Paninis	1 min 30 sec
Frozen Fries 900g	4 min 30 sec

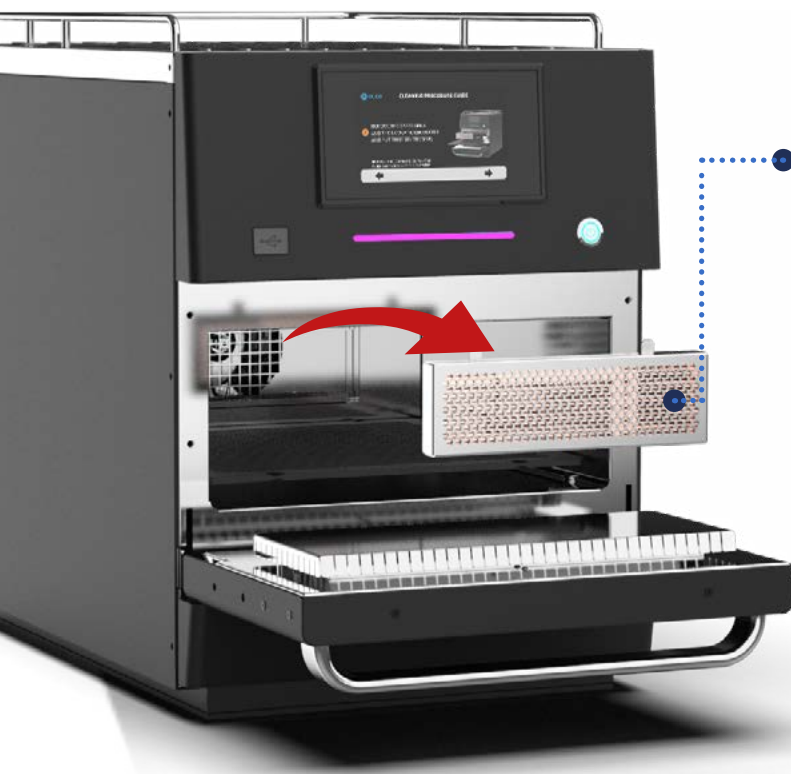

CERTIFIED

**VENTLESS**

WITH EASILY REMOVABLE CATALYTIC CONVERTER.

### Standard accessories



Speed Grill Fit XL



Aluminum Paddle

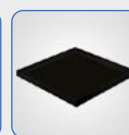

Solid Basket



Fit XL											
Region	Voltage (V)	Phases	Freq. (Hz)	Power (kW)	Circuit breaker (A)	Cable	Socket	Product dimensions (Height x Width x Depth)	Boxed product dimensions (Height x Width x Depth)	Chamber dimensions (Height x Width x Depth)	Clearance (Left   Back   Right side)
Europe	230	Single		6.8	32	3x4	32A(2P+E)	658 x 488 x 795 (mm)	905 x 590 x 960 (mm)	139 x 417 x 410 (mm)	0/0/0 (mm)
	380	Multi	50	6.5	16	5x2.5	16A(3P+N+E)	82kg	103kg	237L	
	400	Multi		6.8	16	5x2.5	16A(3P+N+E)				

\*Prática recommends installing a type D circuit breaker. The electrical installation must comply with local regulations.



## Fit Line Fit ST Stackable

The Fit ST high-speed oven features a 12-inch chamber and can be stacked up to two units high. It is designed to efficiently finish refrigerated, fresh, or frozen foods, such as breakfast sandwiches, chicken wings, muffins, lasagnas, mac & cheese, sub sandwiches, and other partially prepared dishes. Ideal for any business size, the oven delivers excellent flavor, appearance, and crispiness. By combining impinged air and microwaves, it heats, browns, and toasts foods faster than traditional methods.



## Colors

Fit ST Black

Fit ST Silver

- ✔ The FIT ST can be stacked up to 2 units (1+1).
- ✔ Stores unlimited recipes with up to 8 steps each, divided into 16 groups.
- ✔ USB port for system updates and importing/exporting groups, recipes, and settings.
- ✔ Wi-Fi capabilities, enabling remote management for system updates and importing/exporting groups, recipes, and settings via the IOK online platform.
- ✔ Adjustable temperature from 86°F (30°C) to 536°F (280°C).
- ✔ Independent control of impinged air (high-speed air blast) and microwaves.
- ✔ User-friendly touchscreen panel.
- ✔ Constructed from stainless steel.
- ✔ Certified Ventless – no need for vent hoods. Easy-to-remove catalytic converter for hassle-free cleaning.
- ✔ Additional functionalities: Test Mode and Favorites.
- ✔ Daily cleaning guide with explanatory videos displayed on the screen, demonstrating the step-by-step process.
- ✔ Warranty: one (1) year covering manufacturer defects, part failures, and pre-approved labor, and two (2) years on all the heating elements, magnetrons, and blower motor of the oven.

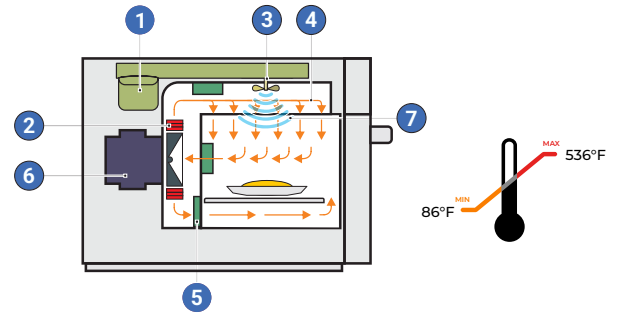

1. Magnetron
2. Resistance (infrared)
3. Stirrer
4. Impinged Air
5. Catalytic Converter
6. Blower Motor
7. Microwaves

## Cook Times

Ham & Cheese Panini	50 sec
Italian Sub	55 sec
Fresh Omelet	1 min 30 sec
Frozen Pizza 30cm	2 min
Steamed Salmon	2 min 30 sec



CERTIFIED

**VENTLESS**

WITH EASILY REMOVABLE CATALYTIC CONVERTER.

### Standard accessories



Speed Grill Fit XL

Aluminum Paddle

Solid Basket

[Click to learn more](#)

### Fit ST Single Mag\*

Region	Voltage (V)	Phases	Freq. (Hz)	Power (kW)	Circuit Breaker (A)	Cable	Socket	Product dimensions (Height x Width x Depth) (mm)	Boxed product dimensions (Height x Width x Depth) (mm)	Chamber dimensions (Height x Width x Depth) (mm)	Clearance (Left   Back   Right side) (mm)
Europe	230	Single	50	3	13 16	3x1,5	13A(2P+E) 16A(2P+E)	425 x 518 x 697 61kg	722 x 620 x 825 83kg	133 x 315 x 308 13L	0 / 0 / 25 (mm)

### Fit ST Double Mag

Region	Voltage (V)	Phases	Freq. (Hz)	Power (kW)	Circuit Breaker (A)	Cable	Socket	Product dimensions (Height x Width x Depth) (mm)	Boxed product dimensions (Height x Width x Depth) (mm)	Chamber dimensions (Height x Width x Depth) (mm)	Clearance (Left   Back   Right side) (mm)
Europe	230 380 400	Single Multi Multi	50	6,8 6,5 6,8	32 16 16	3x4 5x2,5 5x2,5	32A(2P+E) 16A(3P+N+E) 16A(3P+N+E)	425 x 518 x 697 (mm) 72kg	722 x 620 x 825 (mm) 94kg	133 x 315 x 308 (mm) 13L	0 / 0 / 25 (mm)

\*Prática recommends installing a type D circuit breaker. The electrical installation must comply with local regulations.

A C C E S S O R Y

# PANINI PRESS

For FIT Lite, FIT SM, FIT Express and FIT ST - USE ONLY





## The Panini Press is an optional accessory for the FIT Line, ideal for making delicious sandwiches and paninis with grill marks.

- Specifically designed for use with the FIT Express, FIT Lite, Fit SM, and Fit ST.
- It is constructed from aluminum and coated with a non-stick layer.
- Versatility: Accommodates a variety of foods with an opening range of 0.7" to 2.9" between the top and bottom grills.
- Create perfectly pressed, grill-marked paninis, melts, subs, burritos, quesadillas, and more.
- Easy Installation, use, and cleaning.
- Comes with an exclusive paddle for sliding food between the top and bottom plates, also ensuring safe opening and closing.
- It is possible to keep the panini press in the chamber, even when cooking other items without grill marks, by placing the basket on top of it.

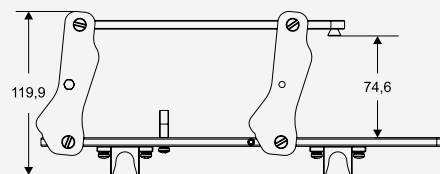
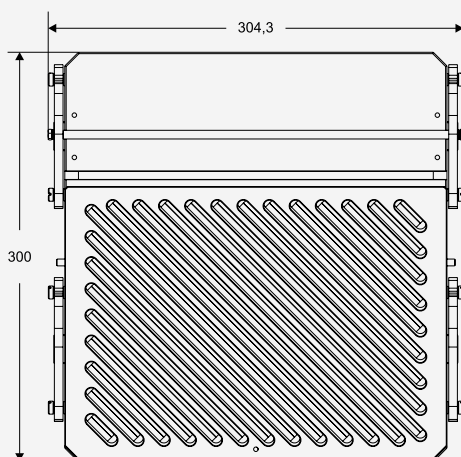

OPEN

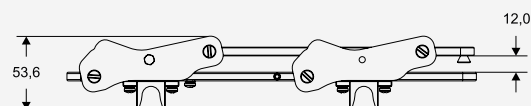

CLOSED



Click to learn more

\*Not recommended for preparing meats



# Get it Ready in 2 taps!



Full color **user-friendly** touchscreen display

## **Elegant and Intuitive**

Our ovens store unlimited recipes, with their own steps, settings, icons, or photos.

## **Simple and Optimized**

A fresh spin on providing a great user interface while simplifying the basic oven operations for the end user.



# Features



Wi-Fi connectivity



Multi-language system

(Portuguese, English, Spanish, French, German, Polish, Russian, Mandarin, Greek)

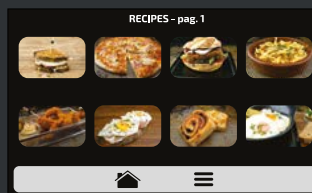

Photo library for recipes



Cleaning guide video with instructions

BACK TO MENU



# Minimal Clearance

Advanced cooling design eliminates side vents and louvers allowing minimal to zero side clearance.

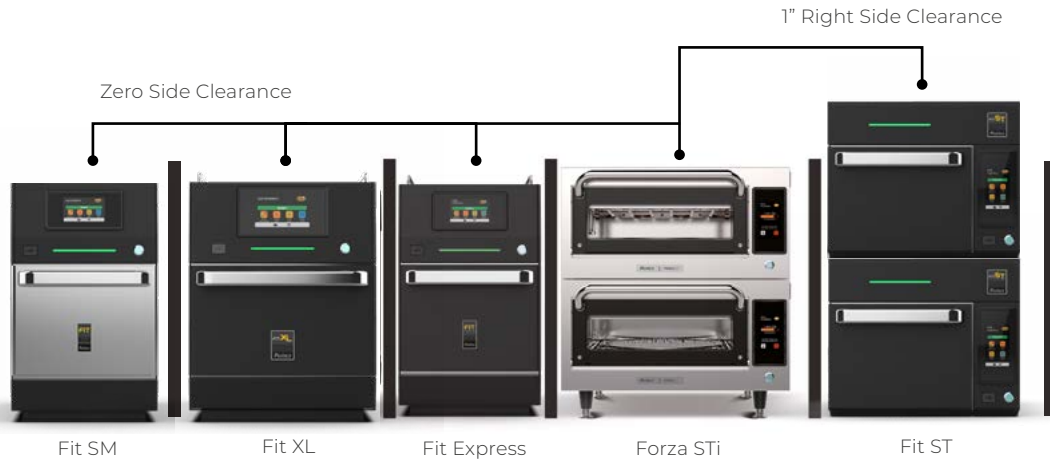

**i**  
Rear clearances are automatically set with factory-installed bumpers.

CERTIFIED

**VENTLESS**

No hoods needed for operation!

The Catalytic Converter turns grease-laden vapor into water, allowing the oven to operate with no need for exhaust hoods.\*

The Catalytic Converter is removable, allowing operators to perform the cleaning without the need for a maintenance service call.

All Prática's high-speed ovens have been tested and passed EPA202, allowing them to be certified as non-grease emitting appliances.

\*The high-speed ovens can't be used to cook foods classified as 'raw fatty proteins', such as bone-in, skin-on chicken, raw bacon, raw hamburger, etc. Failure to comply may damage the catalytic converter.



# PRÁTICA'S SMART HIGH-SPEED OVENS THE FUTURE OF COOKING

IOK is your all-in-one system for smarter kitchen management. It keeps your ovens aligned, your menus consistent, and your business ready to grow—whether you operate one store or many.

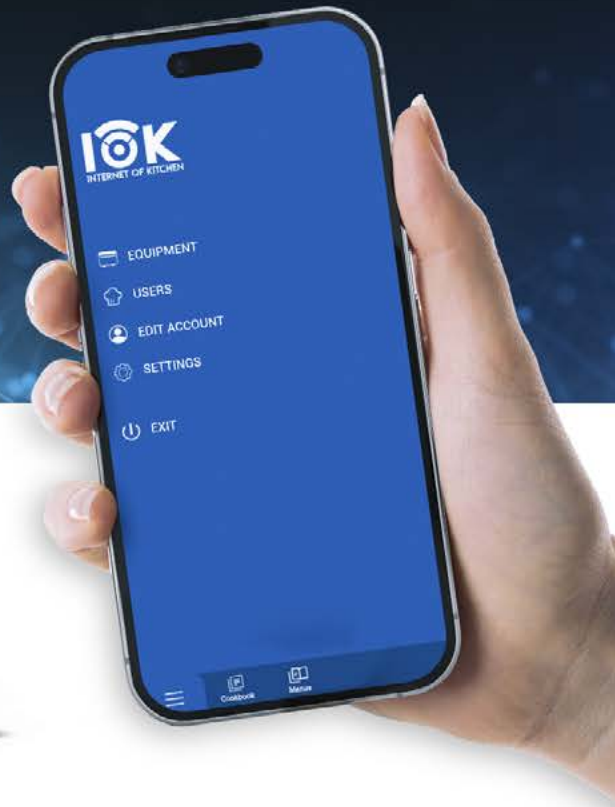

**MANAGE GROUPS AND RECIPES FROM YOUR COMPUTER**

Create, edit, remove, and distribute groups and recipes from the computer to all compatible ovens.



**CUSTOMIZE THE DISPLAY IMAGE OF RECIPES**

Illustrate recipes with real images of your products.



**RECEIVE SOFTWARE UPDATES**

Always count on system improvements for free, from small adjustments to major updates (such as a new interface or function, for example).

# PRÁTICA IOK USES YOUR WI-FI TO ALLOW FOR SEAMLESS MANAGEMENT OF EQUIPMENT ACROSS MULTIPLE LOCATIONS

Standardize your production and keep track of your ovens even when you are out of your kitchen.



All our touchscreen models come with Wi-Fi capabilities and can be connected to the IOK.



The IOK is 100% included with your oven purchase—no extra cost or monthly payments required.



With IOK, you can manage and monitor your equipment from anywhere, on any device—PC, Mac, mobile, or tablet.



Manage all your ovens and menus from one place—no need to handle them separately. Perfect for multi-oven locations and chains.



Create, edit, and organize groups, recipes, and complete menus directly on the oven or from your computer and send them to all connected ovens.



Customize the recipe icons with photos of your own dishes.



The IOK helps with the consistency of your recipe programming which allows your menu and recipes to be consistent from start to finish.



Update your ovens anytime, anywhere—Wi-Fi or USB.



Access the exclusive Cookbook with complete recipe suggestions created by Prática's Chefs.



Get customer support via chat using the IOK platform.



Click to  
learn more



BACK TO MENU

# Speed Ovens Accessories

## Panini Press

**Compatibility:** Fit Lite / Fit Express / Fit SM / Fit ST  
**Part Number:** 800552



## Speed Grill

**Compatibility:** Fit Express / FIT SM / FIT ST | Fit XL  
**Part Number:** 800526 | 800558

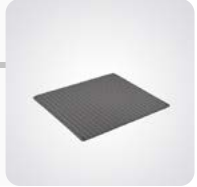

## Solid Basket

**Compatibility:** Fit Express / FIT SM / FIT ST | Fit XL  
**Part Number:** 800525 | 800561



## Pizza Screen

**Compatibility:** Forza STi  
**Part Number:** 760466



## Wave Perforated Basket

**Compatibility:** Fit Express / FIT SM / FIT ST / FIT XL  
**Part Number:** 800540



## Aluminum Paddle

**Compatibility:** Fit Express / FIT SM / FIT ST | Fit XL  
**Part Number:** 800507 | 800560



## Aluminum Paddle Forza STi

**Compatibility:** Forza STi  
**Part Number:** 800512



## Glass Cleaning Tool

**Compatibility:** Forza STi  
**Part Number:** 618213



## Easy Clean Liner

**Compatibility:** Fit Lite / Fit Express / FIT SM / FIT ST / FIT XL  
**Part Number:** 800591







Prática



BACK TO MENU

# Combi Ovens

Ideal for foodservice operations, Prática combi ovens deliver greater productivity, quality and versatility.

With hot air, steam and combi steam functions, they allow operators to bake, cook, fry, grill, steam and much more, preserving flavor, texture, aroma and appearance.

Made of stainless steel, they feature high-performance insulation, efficient energy use, precise temperature control, multipoint core probe, reversing fan system for better heat distribution, and an easy-to-clean cooking chamber.



BACK TO MENU



# TSi Brave

The newest combi oven brings all the intelligence and connectivity you already know, now even more complete and compact.

- ✔ TSi BRAVE: Prática's Intelligent Cooking Center, allowing customers to choose the final result they want for each food.
- ✔ Combi oven functions: Hot Air, Combi Steam, Steam, Delta T, Overnight Cooking and Regeneration.
- ✔ IOK: platform that allows remote production management, creating, editing, deleting or sharing recipes via Wi-Fi.
- ✔ Smart Cleaning: offers cleaning options according to oven soil level, recommending the correct number of tablets for each sanitizing stage.
- ✔ Multiple Cooking: intuitive interface that cooks different types of food simultaneously using saved recipes.
- ✔ Steam Power steam generation system: exclusive technology that provides precise steam generation control with low energy consumption.
- ✔ Adjustable temperature from 30°C to 300°C.
- ✔ Connectivity via Wi-Fi or RJ45 network cable.
- ✔ Active control: optimizes cooking processes through active chamber dehumidification.
- ✔ Exclusive ECOPOWER system that reuses oven heat to improve energy efficiency.
- ✔ Stores up to 1,000 recipes with up to 12 steps each.
- ✔ Favorites function: activates your recipe in just two taps.
- ✔ Core probe with 6 measuring points for internal food temperature control.
- ✔ USB port for HACCP report verification, recipe import and export, software updates and settings.
- ✔ LED lighting on the door, making food preparation easier to view.
- ✔ Triple glass: greater thermal comfort for the surrounding environment.
- ✔ Retractable hand shower: assists with productions that require water for cooking.
- ✔ High-performance ceramic fiber insulation for durability.
- ✔ Built in AISI 444 and AISI 430 stainless steel.
- ✔ 24-month warranty for parts and labor, except for items subject to natural wear. Check the conditions.

# Modulations

## 1 Bases

Individual or for stacking, both with support for GN 2/3 pans to facilitate day-to-day operations.

## 2 Brave Hood

The Gourmet Hood reduces unwanted steam, odors, and smoke resulting from cooking processes. With automatic and silent operation, it activates through intelligent temperature detection.

## 3 Stacking Kit

Gain more versatility with simultaneous cooking in less space by using vertically stacked equipment.

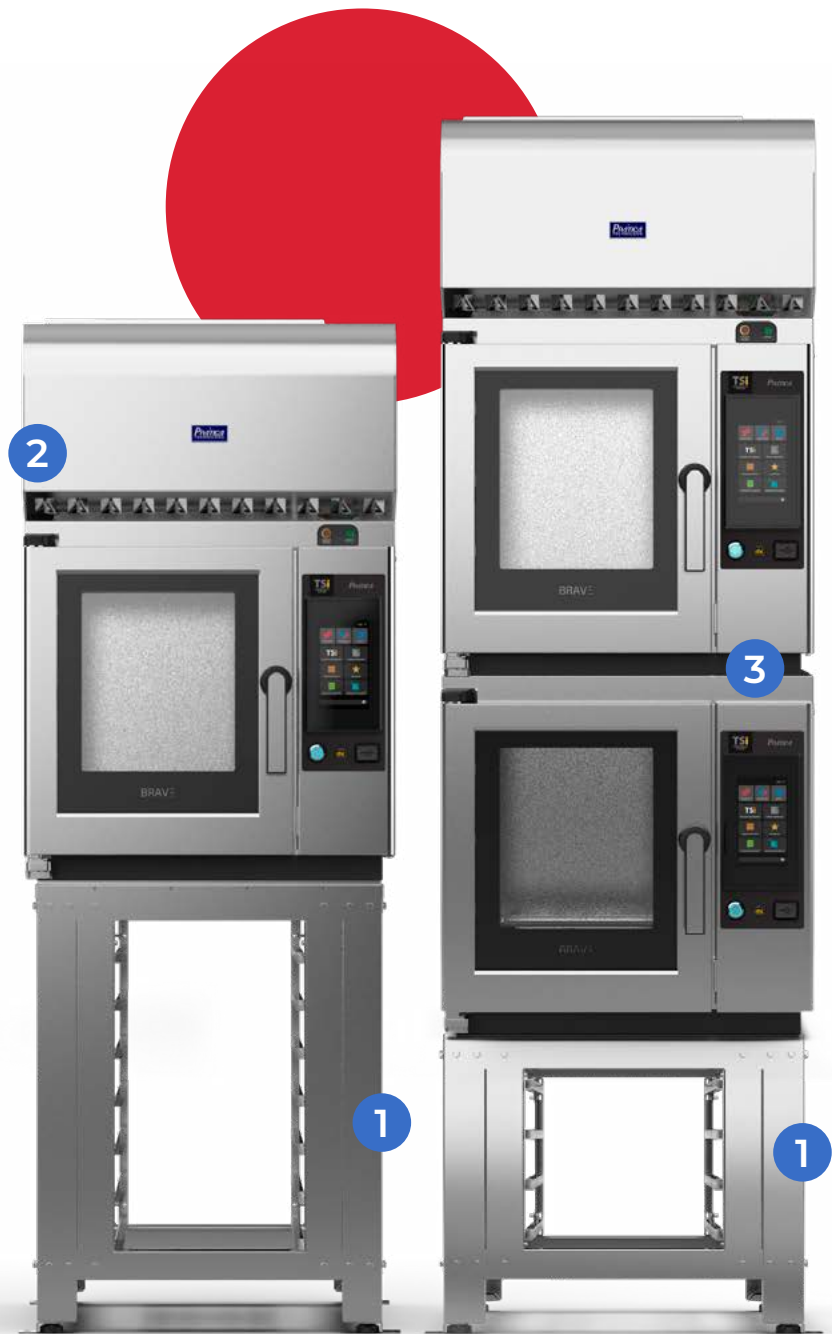

Model	Voltage (V)	Phases	Freq. (Hz)	Power (kW)	Circuit Breaker (A)	Cable (mm <sup>2</sup> )	Socket	Product dimensions (Alt.xLarg.xProf)	Boxed product dimensions (Alt.xLarg.xProf)
<b>TSi Brave</b>	220	Mono	50/60	4.75	32	3x4	32A (2P+T)	609x651x623 (mm) 69kg	858x710x780 (mm) 90kg
<b>Coifa Brave</b>	220	Mono	60	0.35	10	3x1,5	20A (2P+T)	413x651x630 (mm) 44kg	600x1081x750 (mm) 63kg



# Convection Ovens

Prática's bakery ovens are made to achieve productivity, agility, and quality for baking perfectly uniformed bread and pâtisserie products.

Compact ovens easy to install in the production area or visible to the customer on the shop floor.

User-friendly controls and robust all-stainless steel construction.





# Miniconv

Compact, versatile, easy to operate.  
Ideal for production area or visible to the customer on the shop floor.

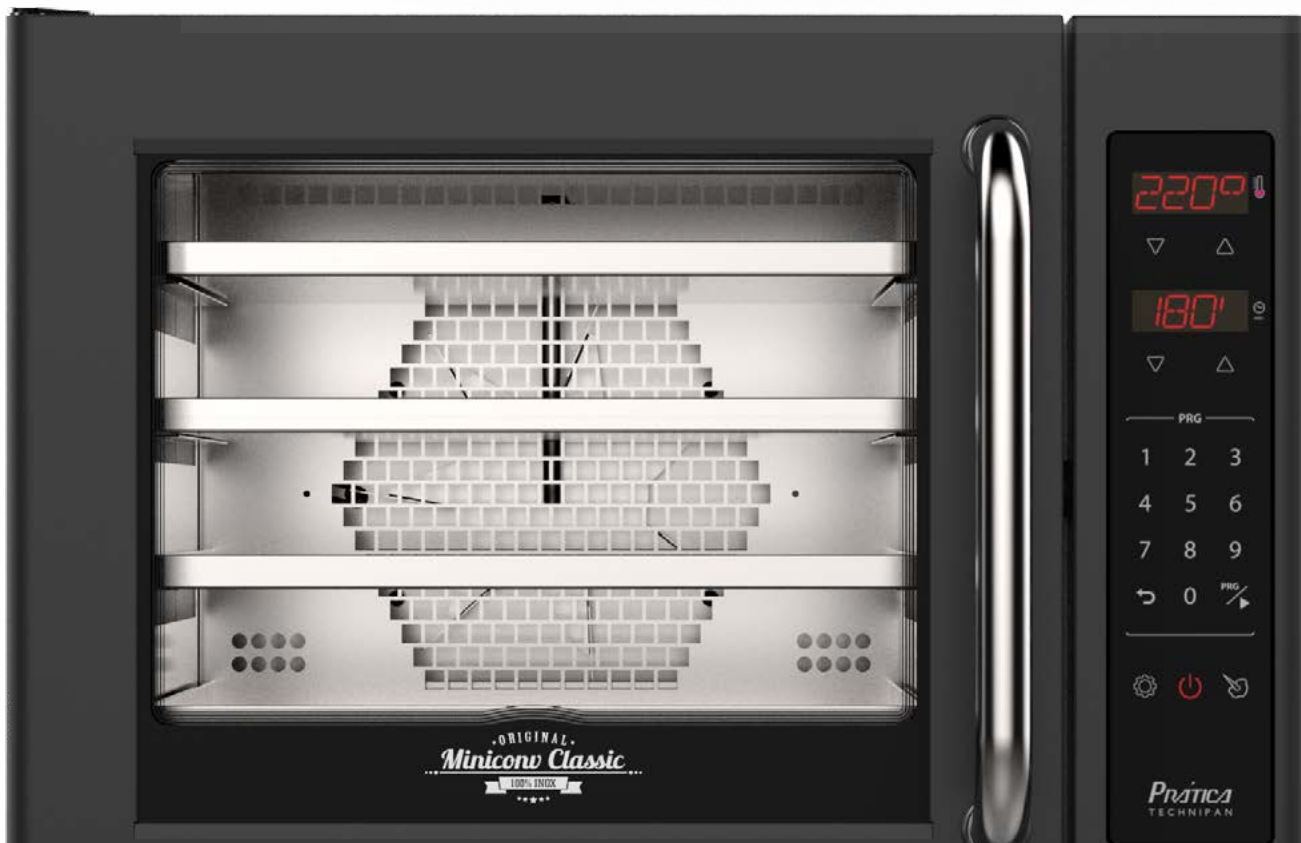



Tray size	35 x 35 cm / 13,7" x 13,7"
Door width	47 cm / 18,5"
Control	Digital programmable
Programation	✓
Number of Recipes	100
Recipe steps	4
Pre-heating	✓
Timing	✓
Convection Off	✓
Heat distribution	Turbine forced convection
USB	✓
Steaming	Water injection
Steam levels	3
Humidity control	✓
Humidity control levels	5
Maximum temperature	230°C / 446°F
Stacking	2 units
Exhaust fan	Recommended



**1 year warranty** for parts and labor, with the exception of naturally worn items.

Model	Voltage (V)	Phases	Freq. (Hz)	Power (kW)	Circuit Breaker (A)	Cable	Socket	Product dimensions (Alt x Larg x Prof)	Boxed product dimensions (Alt x Larg x Prof)
<b>Miniconv Classic Programável</b>	220	Mono	50/60	2.56	16	3x1.5	16A (2P+T)	446x586x694mm <b>32kg</b>	490x650x740mm <b>34kg</b>



BACK TO MENU



# Miniconvx HP

For bakeries, cafes, snack bars, convenience stores and restaurant support and facilities that are meant to serve at all times.



Click to learn more

## Available Colors

## Capacity

4 baking sheets  
46 x 33cm



● Miniconvx HP Black

● Miniconvx HP Inox

- ✔ Stores 100 recipes with up to 4 steps each, plus a preheating step;
- ✔ USB connection for importing and exporting recipes;
- ✔ Stainless steel and black version;
- ✔ Adjustable temperature from 30°C to 250°C;
- ✔ Made of stainless steel;
- ✔ Heating by shielded resistors;
- ✔ Steam generated by water injection at the start of the step;
- ✔ Forced air convection system with air circulation by highperformance turbine, with a reversal system;
- ✔ Function: Convection Off for turbine stop;
- ✔ Chamber lighting;
- ✔ Double tempered and foldable door allowing easy cleaning;
- ✔ Stackable : maximum 1 equipment (1 + 1);
- ✔ Efficient use of energy.



### 1 Side opening door

Facilitates loading and unloading of products.

### 2 Door LED lighting

Better visualization of food cooking.

### 3 Folding double glass

In addition to providing thermal comfort to the environment, it also makes cleaning easier.

 **1 year warranty** for parts and labor, with the exception of naturally worn items.

Model	Voltage (V)	Phases	Freq. (Hz)	Power (kW)	Circuit Breaker (A)	Cable	Socket	Product dimensions (Alt.xLarg.xProf)	Boxed product dimensions (Alt.xLarg.xProf)
<b>Miniconvx HP Prog.</b>	220 230	1	50/60	3,2 3,4	16	3x2,5	16A (2P+E)	453x631x638mm <b>38kg</b>	510x700x760mm <b>44kg</b>



BACK TO MENU



# HPE 80

## Programmable

Attractive and compact, combining the visibility and aroma of bread being baked, offering a unique experience to customers and driving up sales.



**Capacity**  
4 baking sheets 40 x 60cm



BACK TO MENU

Modelo	HPE80 Programmable
Tray Size	40 x 60 cm / 15,7" x 23,6"
Door width	72 cm / 28,3"
Control	Digital programmable
Programmation	✓
Number of recipes	100
Recipe steps	4
Pre-heating	✓
Timing	✓
Convection off	✓
Heat distribution	Turbine forced convection
Reversible turbine	✓
USB	✓
Steaming	Water injection
Steam levels	3
Humidity control	✓
Humidity control levels	5
Maximum temperature	250°C / 482°F
Drain	Não
Stacking	2 units
Exhaust fan	Recommended



**1 year warranty** for parts and labor, with the exception of naturally worn items.

Modelo	Tensão (V)	Fases	Freq. (Hz)	Power (kW)	Circuit Breaker (A)	Cable	Socket	Product dimensions (Alt.xLarg.xProf)	Boxed product dimensions (Alt.xLarg.xProf)
<b>HPE80 Prog.</b>	220	Single	50/60	5.5	32	3x4	32A (2P+E)	600x905x893mm	750x1020x980mm
	230	Single		6.1	32	3x4	32A (2P+E)		
	380	Multi		5.5	16	5x2.5	16A (3P+N+E)		
	400	Multi		6.1	16	5x2.5	16A (3P+N+E)		
								<b>86kg</b>	<b>122kg</b>



BACK TO MENU

*PRÁTICA*